



Quality and reliability is our tradition

KYORITSU



Test and Measuring Instruments
General Catalog 2024

Japan
QUALITY



KYORITSU NEW PRODUCTS

KEW 8601/8602 EVSE ADAPTER

P.66



photo : 8602

KEW 8601

Compact adapter for complete testing of Mode 3 AC EVSE

- EVSE tests under various simulations
 - CP State simulation
 - CP Error / PE Error simulation
- Touch pad for PE voltage check
- L1, L2(N), PE, PP measuring terminals for electrical tests of EVSE
- CP signal terminals for CP signal monitoring
- CAT II 250V rating

KEW 8602

Compact adapter for complete testing of Mode 3 AC EVSE

- EVSE tests under various simulations
 - CP State / PP State simulation
 - CP Error / PE Error simulation
- Touch pad for PE voltage check
- L1, L2, L3, N, PE measuring terminals for electrical tests of EVSE
- CP signal terminals for CP signal monitoring
- Mains socket for load current test (MAX. 10A)
- CAT II 300V rating

KEW 4105DLBT-H EARTH TESTER

P.49

- 3-Pole and 2-Pole Earth Resistance measurement (0.01-2000 Ω)
- Waterproof design (IP67)
- Bluetooth® enabled for data transfer
- Noise rejection up to 25V rms allows accurate testing in noisy environments
- Large LCD Display with Backlight



KEW
CONNECT

CONTENTS

SYMBOLS

	TRUE RMS
	CAT IV 600V
	DC/AC V
	DC/AC A
	DC Voltage
	AC Voltage
	DC Current (A)
	AC Current (A)
	DC+AC measurement
	Power
	MAX MIN AVG
	MAX MIN
	Resistance
	Continuity buzzer
	Diode
	Capacitance
	Temperature
	Frequency
	Power factor
	Harmonics
	Phase rotation
	Decibel
	Duty cycle ratio
	Non Contact Voltage
	Backlight
	Water proof
	Peak hold
	Data hold
	Auto power off
	Auto power save
	Output
	Filter
	Relative
	External Power Supply
	USB
	Low power Ω
	Bluetooth®

MULTIMETERS

1009, 1011/1012, 1019R, 1020R/1021R, 1030, 1051/1052, 1061/1062, 1109S, 1110, 2000A/2001A/2012RA

P.13 - P.20

CLAMP METERS

2002PA/2002R, 2003A, 2007R, 2009R, 2010, 2031, 2033, 2046R, 2055/2056R, 2117R, 2127R, 2200/2200R, 2204R, 2210R, 2300R, 2413F/2413R, 2431, 2432, 2433/2433R, 2434, 2500/2510, 8112, 8115, 8161

P.21 - P.33

INSULATION TESTERS

3005A, 3007A, 3025B/3125B, 3121B/3122B, 3123A, 3124A, 3127, 3128, 3131A, 3132A, 3161A, 3165/3166, 3431, 3551/3552/3552BT

P.34 - P.45

EARTH TESTERS

4102A/4102A-H, 4105A/4105A-H, 4105DL/4105DL-H, 4105DLBT-H, 4106, 4200/4202, 4300

P.46 - P.52

LOOP/PSC/RCD TESTERS

4118A, 4140, 5406A, 5410

P.53 - P.56

PORTABLE APPLIANCE TESTERS

6205

P.57 - P.58

MULTI FUNCTION TESTERS

6010B, 6011A, 6018, 6024PV, 6516/6516BT

P.59 - P.65

EVSE ADAPTERS

8601/8602

P.66 - P.67

POWER METERS

2060BT/2062/2062BT, 6305, 6315

P.68 - P.73

LOGGERS

5010/5020, 5050

P.74 - P.77

SENSORS

8121, 8122, 8123, 8124, 8125, 8126, 8127, 8128, 8130, 8133, 8135, 8146, 8147, 8148, 8177, 8178, 8309

P.78 - P.80

INTELLIGENT SOCKET TESTERS

4506, 8343

P.81 - P.83

OTHERS

5202, 5204/5204BT, 5515, 5711, 8031/8031F, 8035

P.84 - P.85

KEWTECH

KT170/171, KT200, KT203

P.86 - P.87

ACCESSORIES

Test Leads, Fuse

P.88 - P.93

GLOSSARY/PRODUCT INDEX/QUALITY CONTROL CONCEPT

P.94 - P.99



Please read the "Safety Warnings" in the instruction manual supplied with the instrument thoroughly and completely for safety use. Failure to follow the safety rules can cause fire, trouble, electrical shock, etc. Therefore, make sure to operate the instrument on a correct power supply and voltage rating marked on each instrument.

MULTIMETERS
CLAMP METERS
INSULATION TESTERS
EARTH TESTERS
LOOP/PSC/RCD TESTERS
PORTABLE APPLIANCE TESTERS
MULTI FUNCTION TESTERS
EVSE ADAPTERS
POWER METERS
LOGGERS
SENSORS
INTELLIGENT SOCKET TESTERS
OTHERS
KEWTECH
ACCESSORIES
GLOSSARY/PRODUCT INDEX/QUALITY CONTROL CONCEPT

KYORITSU LINE UP

ANALOG MULTIMETERS

DIGITAL MULTIMETERS

<p>KEW 1109S</p> <p>P16</p>  <p>CE</p>	<p>MODEL 1110</p> <p>P16</p>  <p>CE</p>	<p>MODEL 1009</p> <p>P16</p>  <p>CE</p>	<p>KEW 1011</p> <p>P16</p>  <p>CE</p>	<p>KEW 1012</p> <p>P16</p>  <p>CE TRUE RMS</p>	<p>KEW 1019R</p> <p>P17</p>  <p>CE TRUE RMS</p>	<p>KEW 1020R</p> <p>P15</p>  <p>CE TRUE RMS</p>	<p>KEW 1021R</p> <p>P15</p>  <p>CE TRUE RMS</p>
--------------------------------------------------------------------------------------------------------------------------------	---------------------------------------------------------------------------------------------------------------------------------	---------------------------------------------------------------------------------------------------------------------------------	-------------------------------------------------------------------------------------------------------------------------------	--------------------------------------------------------------------------------------------------------------------------------------------	----------------------------------------------------------------------------------------------------------------------------------------------	-----------------------------------------------------------------------------------------------------------------------------------------------	-----------------------------------------------------------------------------------------------------------------------------------------------

AC CLAMP METERS

<p>MODEL 2002PA</p> <p>P24</p>  <p>CE 2002R TRUE RMS Φ55 MAX AC2000A</p>	<p>KEW 2007R</p> <p>P24</p>  <p>CE TRUE RMS Φ33 MAX AC1000A</p>	<p>MODEL 2031</p> <p>P24</p>  <p>CE Φ24 MAX AC 200A</p>	<p>KEW 2117R</p> <p>P25</p>  <p>CE TRUE RMS Φ33 MAX AC1000A</p>	<p>KEW 2127R</p> <p>P25</p>  <p>CE TRUE RMS Φ33 MAX AC1000A</p>	<p>KEW 2200/2200R</p> <p>P25</p>  <p>CE 2200R TRUE RMS Φ33 MAX AC1000A</p>	<p>KEW 2204R</p> <p>P26</p>  <p>CE TRUE RMS Φ70 MAX AC 400A</p>
----------------------------------------------------------------------------------------------------------------------------------------------------------------------------------	---------------------------------------------------------------------------------------------------------------------------------------------------------------------	---------------------------------------------------------------------------------------------------------------------------------------------------------	---------------------------------------------------------------------------------------------------------------------------------------------------------------------	----------------------------------------------------------------------------------------------------------------------------------------------------------------------	--------------------------------------------------------------------------------------------------------------------------------------------------------------------------------------	-----------------------------------------------------------------------------------------------------------------------------------------------------------------------

DIGITAL CLAMP METERS

LEAKAGE CLAMP METERS

<p>KEW 2500/2510</p> <p>P29</p>  <p>CE Φ6</p>	<p>KEW 2300R</p> <p>P31</p>  <p>CE TRUE RMS Φ10 MAX AC100A</p>	<p>KEW 2413F/2413R</p> <p>P31</p>  <p>CE 2413R TRUE RMS Φ68 MAX AC1000A</p>	<p>MODEL 2431</p> <p>P30</p>  <p>CE Φ24 MAX AC 200A</p>	<p>MODEL 2432</p> <p>P30</p>  <p>CE Φ40 MAX AC 100A</p>	<p>MODEL 2433/2433R</p> <p>P30</p>  <p>CE 2433R TRUE RMS Φ40 MAX AC 400A</p>	<p>MODEL 2434</p> <p>P31</p>  <p>CE Φ28 MAX AC 100A</p>
--------------------------------------------------------------------------------------------------------------------------------------------	---------------------------------------------------------------------------------------------------------------------------------------------------------------------	--------------------------------------------------------------------------------------------------------------------------------------------------------------------------------------	----------------------------------------------------------------------------------------------------------------------------------------------------------	-----------------------------------------------------------------------------------------------------------------------------------------------------------	-----------------------------------------------------------------------------------------------------------------------------------------------------------------------------------------	------------------------------------------------------------------------------------------------------------------------------------------------------------

HIGH VOLTAGE INSULATION TESTERS

<p>KEW 3121B/3122B</p> <p>P41</p>  <p>CE 3121B(2500V) 3122B(5000V)</p>	<p>KEW 3123A</p> <p>P42</p>  <p>3123A(5000/10000V)</p>	<p>KEW 3124A</p> <p>P42</p>  <p>3124A(1k -10kV Variable)</p>	<p>KEW 3025B/3125B</p> <p>P43</p>  <p>CE 3025B(250/500/1000/2500V) 3125B(250/500/1000/2500/5000V)</p>	<p>KEW 3127</p> <p>P44</p>  <p>CE 3127(250/500/1000/2500/5000V)</p>	<p>KEW 3128</p> <p>P45</p>  <p>CE 3128(500/1000/2500/5000/10000/12000V)</p>
-------------------------------------------------------------------------------------------------------------------------------------------------------------------------	--------------------------------------------------------------------------------------------------------------------------------------------------	--------------------------------------------------------------------------------------------------------------------------------------------------------	---------------------------------------------------------------------------------------------------------------------------------------------------------------------------------------------------------	---------------------------------------------------------------------------------------------------------------------------------------------------------------------	-----------------------------------------------------------------------------------------------------------------------------------------------------------------------------

LOOP/PSC TESTERS

RCD TESTERS

PORTABLE APPLIANCE TESTER

MULTI FUNCTION TESTERS

<p>MODEL 4118A</p> <p>P54</p>  <p>CE</p>	<p>KEW 4140</p> <p>P55</p>  <p>CE</p>	<p>MODEL 5406A</p> <p>P56</p>  <p>CE</p>	<p>KEW 5410</p> <p>P56</p>  <p>CE</p>	<p>KEW 6205</p> <p>P58</p>  <p>CE</p>	<p>KEW 6010B</p> <p>P60</p>  <p>CE</p>	<p>MODEL 6011A</p> <p>P61</p>  <p>CE</p>	<p>MODEL 6018</p> <p>P61</p>  <p>CE</p>
-----------------------------------------------------------------------------------------------------------------------------------	---------------------------------------------------------------------------------------------------------------------------------	------------------------------------------------------------------------------------------------------------------------------------	---------------------------------------------------------------------------------------------------------------------------------	---------------------------------------------------------------------------------------------------------------------------------	-----------------------------------------------------------------------------------------------------------------------------------	--------------------------------------------------------------------------------------------------------------------------------------	-------------------------------------------------------------------------------------------------------------------------------------

POWER METERS

LOGGERS

INTELLIGENT SOCKET TESTERS

OTHERS

<p>KEW 6305</p> <p>P70</p>  <p>CE TRUE RMS</p>	<p>KEW 6315</p> <p>P72</p>  <p>CE TRUE RMS</p>	<p>KEW 5010/5020</p> <p>P74</p>  <p>CE TRUE RMS</p>	<p>KEW 5050</p> <p>P76</p>  <p>CE TRUE RMS</p>	<p>KEW 4506</p> <p>P82</p>  <p>CE NEW</p>	<p>KEW 8343</p> <p>P82</p>  <p>CE NEW</p>	<p>MODEL 5202</p> <p>P84</p>  <p>CE</p>
----------------------------------------------------------------------------------------------------------------------------------------------	----------------------------------------------------------------------------------------------------------------------------------------------	---------------------------------------------------------------------------------------------------------------------------------------------------	----------------------------------------------------------------------------------------------------------------------------------------------	-----------------------------------------------------------------------------------------------------------------------------------------	-------------------------------------------------------------------------------------------------------------------------------------------	-------------------------------------------------------------------------------------------------------------------------------------

DIGITAL MULTIMETERS

KEW 1030	KEW 1051	KEW 1052	KEW 1061	KEW 1062	KEW MATE 2000A	KEW MATE 2001A	KEW MATE 2012RA
P17	P18	P18	P18	P18	P20	P20	P20
CE	CE TRUE RMS	CE TRUE RMS	CE TRUE RMS	CE TRUE RMS	CE Φ6 MAX AC/DC 60A	CE Φ10 MAX AC/DC 100A	CE Φ12 MAX AC/DC 120A

AC CLAMP METERS

AC/DC CLAMP METERS

KEW 2210R	KEW 2003A	KEW 2009R	MODEL 2010	MODEL 2033	KEW 2046R	KEW 2055/2056R
P26	P27	P27	P27	P28	P28	P28
CE TRUE RMS Φ150 MAX AC 3000A	CE Φ55 MAX AC/DC 2000A	CE TRUE RMS Φ55 MAX AC/DC 2000A	CE Φ7.5 MAX AC/DC 20A	CE Φ24 MAX AC/DC 300A	CE TRUE RMS Φ33 MAX AC/DC 600A	CE 2056R TRUE RMS Φ40 MAX AC/DC 1000A

INSULATION/CONTINUITY TESTERS

ANALOG INSULATION TESTERS

MODEL 3005A/3007A	KEW 3551	MODEL 3131A	MODEL 3132A	MODEL 3161A	MODEL 3165/3166	KEW 3431
P36	P37	P38	P38	P39	P39	P39
CE 3005A/3007A (250V/500V/1000V)	CE 3551/3552/3552BT (50V/100V/125V/250V/500V/1000V)	CE 3131A(250V/500V/1000V)	CE 3132A(250V/500V/1000V)	CE 3161A(15V/500V)	3165(500V) 3166(1000V)	CE 3431(250V/500V/1000V)

EARTH TESTERS

EARTH CLAMP TESTERS

MODEL 4102A	KEW 4105A	KEW 4105DL	KEW 4105DLBT-H	KEW 4106	KEW 4300	MODEL 4200	MODEL 4102A-H	KEW 4105A-H	KEW 4105DL-H	MODEL 4202
P50	P50	P48	P49	P51	P51	P52	P50	P50	P48	P52
CE	CE	CE	CE	CE	CE	CE	CE	CE	CE	CE

MULTI FUNCTION TESTERS

EVSE ADAPTERS

POWER METERS

KEW 6516/6516BT	KEW 6024PV	KEW 8601	KEW 8602	KEW 2060BT	KEW 2062/2062BT
P64	P62	P66	P66	P69	P69
CE	CE TRUE RMS	CE	CE	CE TRUE RMS Φ75	CE TRUE RMS Φ55

OTHERS

KEWTECH

KEW 5204/5204BT	KEW 5515	KEW 5711	KEW 8035	KEW 8031/ 8031F	KT 170/171	KT 200/203
P84	P85	P84	P85	P85	P87	P86
CE	CE	CE	CE	CE	CE	CE Φ30 MAX AC 400A

INDUSTRIAL

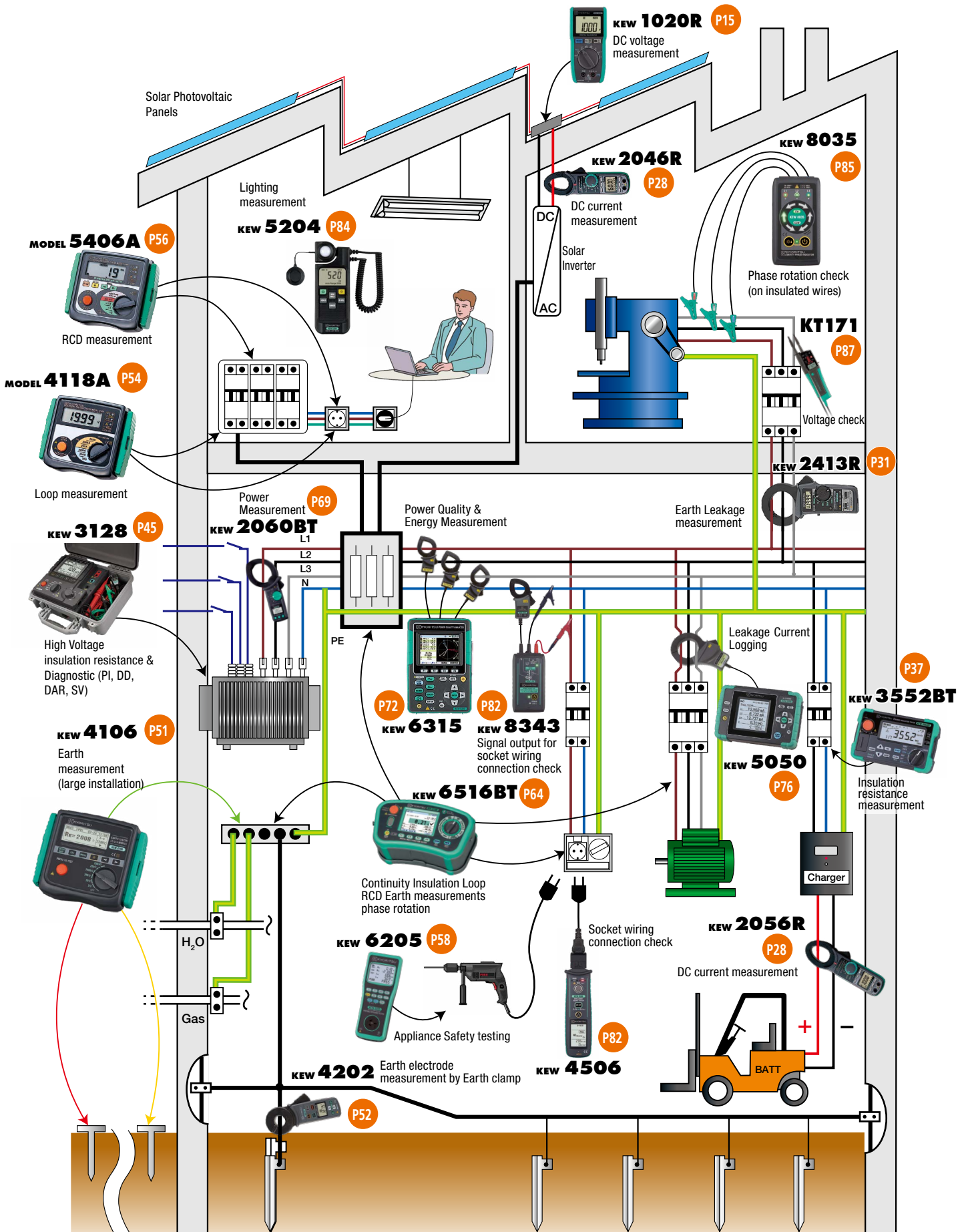

RESIDENTIAL

KEW 6024PV P62



PV Insulation measurement

P84

KEW 5711
Voltage detect



Lighting measurement
MODEL 5202 P84



DC current measurement



KEW MATE 2012RA P20

Solar Photovoltaic panels

Solar Inverter

KEW 6305 P70

Power & Energy measurement



MODEL 3132A

P38



Insulation resistance measurement

KEW 2300R P31

AC current measurement



KEW 1021R
Voltage measurement P15



KEW 2117R

P25 AC Current measurement



Voltage and Phase Neutral check
KT170



P87

EVSE operation and safety test

KEW 8602

P66



KEW 8343
Signal output for socket wiring connection check



P82

KEW 4506
Socket wiring connection check

P82



MODEL 2434 Earth Leakage measurement



P31

KEW 4140 P55

Loop measurement



KEW 6516 P64

Continuity Insulation Loop RCD Earth measurements



KEW 4506

P82



Appliance Safety Testing
KEW 6205



P58

Earth measurement

KEW 4105DL

P48



H₂O

Gas

Special measurement application "KEW CONNECT"

Do you have anything trouble you at work?

A lot of test points and takes enormous working time.
Time consuming report creation work.
Manual input often brings typing errors.
Troublesome data input work after returning office.



solves such problems!

1

Transfers measured values to tablet or smartphone!

2

Quick data creation!
Possible to save in CSV format to e-mail the data.



Measurement



Data transfer

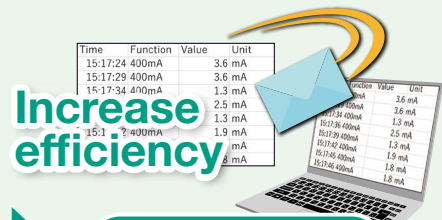

Increase efficiency

Report creation

Models supported by KEW CONNECT:



KEW Smart Advanced



KEW Power*



KEW 6516BT P64
MULTI FUNCTION TESTER



KEW 3552BT P37
DIGITAL INSULATION/CONTINUITY TESTER



KEW 2060BT P69
CLAMP POWER METER



KEW 2062BT P69
CLAMP POWER METER



KEW 5204BT P84
DIGITAL LIGHT METER



KEW 4105DLBT-H P49
EARTH TESTER



Download from Google Play Store for FREE.



Download from App Store for FREE.

Detailed explanation of the application is available on our website.

* Please note that communication charge is incurred separately for downloading the applications.

* Please visit our website to check the supported versions of Android™ and iOS.

* Bluetooth® is the trademark or registered trademark of Bluetooth SIG.

* Android™ is the trademark or registered trademark of Google Inc.

* iOS is the trademark or registered trademark of Cisco in the U.S. and other countries and is used under license.

Special measurement application “KEW CONNECT”



Simplified monitoring

Real-time display and measured data save function.



Real-time display and syncing data save on KEW Smart Advanced



Numerical and graphical display are available on KEW Power*

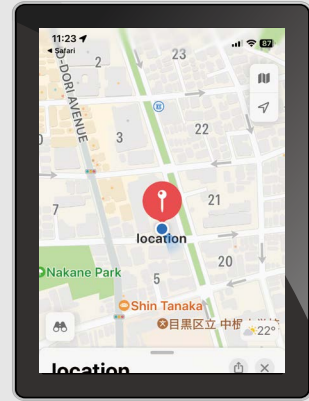

Auto-save of location info



Report creation

Measured values can be entered in the original Excel report template.

Other customized templates are importable.

Result auto entry

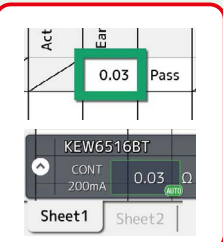

Measured values are automatically entered in Excel template.

Text entry

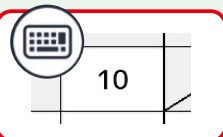

Any text is freely entered.

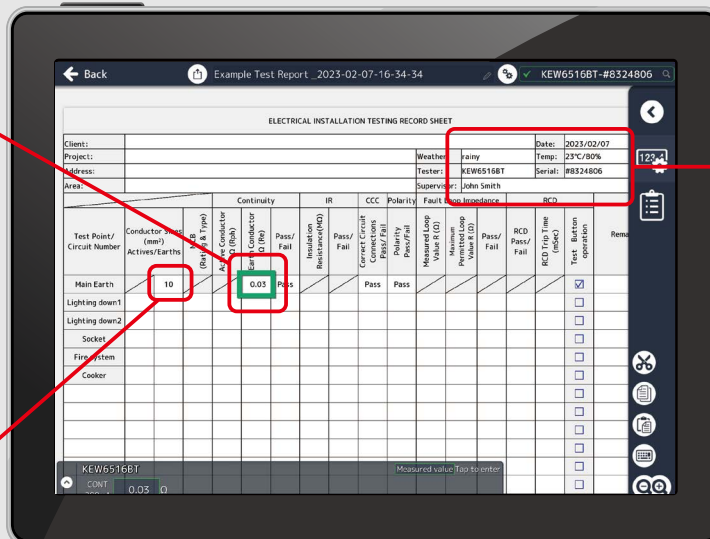

Text template

Fixed stocks

KEW6516BT #8324806
2023年 2月 7日
2023/02/07 2023 2/7

User registered:

John Smith
Pass Fail None

sunny cloudy rainy

Date, paired device model name, and serial number are selectable from the fixed stocks box. Possible to add user original texts.

Upper limit change

Upper limit change of recording

Upper limit of insulation resistance value[50V]

If measured value is greater than 10.0 MΩ ,
automatically enter >10 MΩ in the corresponding cell(s).

Upper limit of insulation resistance value[100V]

If measured value is greater than 100.0 MΩ ,

Wishing to limit the values to be entered in the report up to 100 MΩ? Then change the record upper limit and select desired max value.

Cursor auto movement

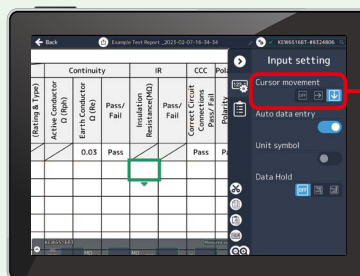

Cursor movement

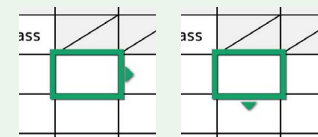

Move horizontally

Move vertically

Cursor automatically moves to next cell after entering value or text. Settings of cursor move direction and movement are available.

SELECTION GUIDE

Selection Guide of Multimeters

TRUE RMS True RMS type

Analog	Basic model	1109S	P16	Mirrored scale for easy and accurate reading
		1110	P16	High sensitive DC20kΩ/V
Digital	Card type	1019R	P17	TRUE RMS Pocket size tester
	Pen type	1030	P17	Pen type tester
	Handheld type	1009	P16	Basic model
		1011	P16	with Temperature measurement
		1012	P16	TRUE RMS
		1020R	P15	TRUE RMS CAT IV 300V, AC/DC 1000V
		1021R	P15	TRUE RMS CAT IV 300V, AC/DC 600V, AC/DC 10A
		1051/1052	P18	TRUE RMS DC accuracy 0.09%, PC connection *1052 only
	With Clamp sensor KEW MATE Series	1061/1062	P18	TRUE RMS DC accuracy 0.02%, PC connection
		2000A	P20	Conductor size φ6mm AC/DC 60A
2001A		P20	Conductor size φ10mm AC/DC 100A	
2012RA		P20	TRUE RMS Conductor size φ12mm AC/DC 120A	



Selection Guide of Clamp Meters

TRUE RMS True RMS type

DC AC V AC/DC Volt.

AC current measurement	Small conductor size	2031	φ24mm	P24	0.01 to 200A
	Medium conductor size	2007R	φ33mm	P24	TRUE RMS DC AC V 0.1 to 1000A
		2117R	φ33mm	P25	TRUE RMS DC AC V 0.01 to 1000A, Non Contact Voltage
		2127R	φ33mm	P25	TRUE RMS DC AC V 0.01 to 1000A, Peak hold, Backlight
		2200	φ33mm	P25	DC AC V 0.01 to 1000A
		2200R	φ33mm	P25	TRUE RMS DC AC V 0.01 to 1000A
	Large conductor size	2002PA	φ55mm	P24	DC AC V 0.1 to 2000A
		2002R	φ55mm	P24	TRUE RMS DC AC V 0.1 to 2000A
	Flexible type	2204R	φ70mm	P26	TRUE RMS 0.001 to 400A
		2210R	φ150mm	P26	TRUE RMS 0.01 to 3000A



AC/DC current measurement	Small conductor size	2010	φ7.5mm	P27	AC 0.1mA to 20A / DC 0.001 to 20A
		2300R	φ10mm	P31	TRUE RMS AC/DC 0.1 to 100A Open jaw
		2033	φ24mm	P28	AC/DC 0.01 to 300A
	Medium conductor size	2046R	φ33mm	P28	TRUE RMS DC AC V AC/DC 0.1 to 600A
		2055	φ40mm	P28	DC AC V AC/DC 0.1 to 1000A
		2056R	φ40mm	P28	TRUE RMS DC AC V AC/DC 0.1 to 1000A
	Large conductor size	2003A	φ55mm	P27	DC AC V AC/DC 0.1 to 2000A
		2009R	φ55mm	P27	TRUE RMS DC AC V AC/DC 0.1 to 2000A



DC MILLIAMP CLAMP METER/ CLAMP LOGGER	Small conductor size	2500	φ6mm	P29	DC 0.01 to 120.0mA, 4 to 20mA (%)
		2510	φ6mm	P29	DC 0.01 to 120.0mA, 4 to 20mA (%), Memory function, Bluetooth communication function

SELECTION GUIDE

Selection Guide of Clamp Meters

TRUE RMS True RMS type

Leakage current measurement

Small conductor size

2431 ϕ 24mm P30 0.01mA to 200A

Medium conductor size

2434 ϕ 28mm P31 0.1mA to 100A

2432 ϕ 40mm P30 0.001mA to 100A High sensitive model

2433 ϕ 40mm P30 0.01mA to 400A

2433R ϕ 40mm P30 **TRUE RMS** 0.01mA to 400A

Large conductor size

2413F ϕ 68mm P31 0.1mA to 1000A

2413R ϕ 68mm P31 **TRUE RMS** 0.1mA to 1000A



Selection Guide of Insulation/Continuity Testers



photo : 3552BT

Type	Range	MODEL		Rated voltage											
				15V	50V	100V	125V	250V	500V	1000V	2500V	5000V	1k - 10kV	10kV	12kV
Analog	1 range	3165	P39						●						
	1 range	3166	P39							●					
	2 ranges	3161A	P39	●					●						
	3 ranges	3131A	P38					●	●	●					
	3 ranges	3132A	P38					●	●	●					
	3 ranges	3431	P39					●	●	●					
Digital	3 ranges	3005A	P36					●	●	●					
	3 ranges	3007A	P36					●	●	●					
	6 ranges	3551	P37		●	●	●	●	●	●					
	6 ranges	3552	P37		●	●	●	●	●	●					
	6 ranges	3552BT	P37		●	●	●	●	●	●					
High Voltage	1 range	3121B	P41								●				
	1 range	3122B	P41									●			
	2 ranges	3123A	P42									●	●		
	Variable	3124A	P42							●		●			
	4 ranges	3025B	P43					●	●	●	●				
	5 ranges	3125B	P43					●	●	●	●	●			
	5 ranges	3127	P44					●	●	●	●	●	●		
	6 ranges	3128	P45						●	●	●	●	●	●	●

Selection Guide of Earth Testers



3-Pole method
2-Pole method

Analog

4102A P50 Soft case model

4102A-H P50 Hard case model

Digital

4105A P50 Soft case model

4105A-H P50 Hard case model

4105DL P48 Soft case model, IP67 Waterproof

4105DL-H P48 Hard case model, IP67 Waterproof

4105DLBT-H P49 Hard case model, IP67 Waterproof, Bluetooth communication function

4106 P51 Earth resistivity model

Earth clamp

Digital

4200 P52 For Multiple Earthing system

4202 P52 For Multiple Earthing system, Bluetooth communication function

2-Pole method

Digital

4300 P51 Dedicated earth tester for 2-Pole method

SELECTION GUIDE

Selection Guide of Multi Function Testers

Digital	6010B	P60	5 in 1
	6011A	P61	5 in 1
	6024PV	P62	PV Insulation, Insulation, Earth resistance, Voltage
	6516	P64	12 in 1
	6516BT	P64	12 in 1, Bluetooth communication function



Selection Guide of Power Meters

Clamp Power Meter	2060BT	φ75mm	P69	Voltage, Current, Power, Frequency, Harmonics, 4ch, Bluetooth communication function
	2062	φ55mm	P69	Voltage, Current, Power, Frequency, Harmonics, 4ch
	2062BT	φ55mm	P69	Voltage, Current, Power, Frequency, Harmonics, 4ch, Bluetooth communication function
Power Meter	6305	P70	Energy, Voltage, Current, Power, 6ch, USB, Bluetooth communication function	
Power Quality Analyzer	6315	P72	Power quality, Energy, Voltage, Current, Power, Frequency, 7ch, USB, Bluetooth communication function	

Selection Guide of Loggers

For current	5010	P74	For Current, Inrush current, 3ch
For current/Voltage	5020	P74	For Current/Voltage, Swell, Dip, Interruption, Inrush current, 3ch
For Ior	5050	P76	Ior Leakage current, Current, Voltage, Frequency, 5ch

Selection Guide for Other Testers

LOOP/PSC Tester	4118A	P54	15mA LOOP test, PSC Test, IP54 Rainproof
	4140	P55	ATT (Anti-Trip Technology), PSC Test, PFC Test
RCD Tester	5406A	P56	Test current up to 500mA, RCD Type A and AC, Operating voltage up to 253V, IP54 Rainproof
	5410	P56	Test current up to 500mA, RCD Type AC, Operating voltage up to 440V, IP54 Rainproof
Portable Appliance Tester	6205	P58	Class I Test, Class II Test, Extension Lead Test, RCD Test
Intelligent socket tester N-E Polarity Tester	4506	P82	2 Pole/3 Pole socket, Polarity and Wiring test, N-E Loop resistance test
Light Meter	5202	P84	0.1 to 19990lx
	5204	P84	0.1 to 199900lx
	5204BT	P84	0.1 to 199900lx, Bluetooth communication function
Infrared Thermometer	5515	P85	-32 to 535°C
Voltage Detector	Low voltage	5711	P84 AC 20 to 1000V, LED light
Phase Indicator	Non-Contact type	8035	P85 Safe measurement over insulated cables, AC 70 to 1000V
	Contact type	8031	P85 Phase Indicator with open phase checker
		8031F	P85 Phase Indicator with fused test leads



MULTIMETERS

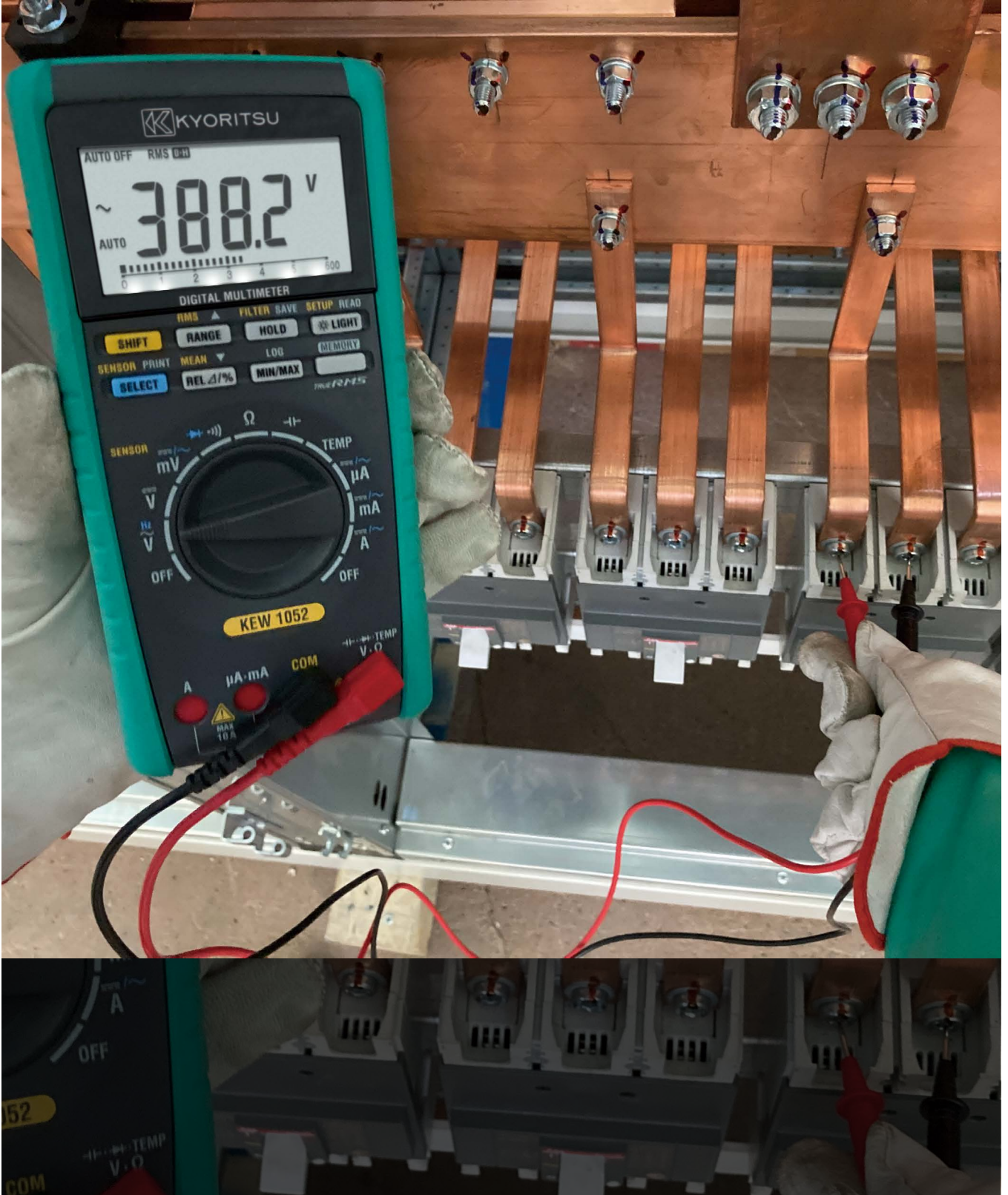

MULTIMETERS

Selection Guide of Multimeters

	Analog Multimeters			Digital Multimeters									
	1109S	1110	1019R	1020R	1021R	1030	1009	1011 1012	1051 1052	1061 1062	2000A 2001A	2012RA	
Appearance													
Detection method	-	-	✓	✓	✓	-	-	✓ (1012)	✓	✓	-	✓	
Maximum count display	-	-	6000	6000	6000	4000	3999	6000	6000	50000	3400	6000	
DC Basic accuracy	±3% of FS	±3% of FS	0.8%	0.5%	0.5%	0.8%	0.6%	0.5%	0.09%	0.02%	1.5%	1.0%	
Frequency response	30Hz - 20kHz	50Hz - 5kHz	45 - 500Hz	40 - 500Hz	40 - 500Hz	50 - 400Hz	50 - 400Hz	40Hz - 1kHz	40Hz - 1kHz	10Hz - 20kHz(1061) 10Hz - 100kHz(1062)	50 - 400Hz	45 - 400Hz	
Measurement													
DC V	Max	1000V	600V	600V	1000V	600V	600V	600V	600V	1000V	1000V	600V	600V
	Resolution	0.002V	0.005V	0.1mV	0.1mV	0.1mV	0.1mV	0.1mV	0.1mV	0.1mV	0.001mV	0.1mV	0.1mV
AC V	Max	1000V	600V	600V	1000V	600V	600V	600V	600V	1000V	1000V	600V	600V
	Resolution	0.2V	0.2V	0.001V	0.1mV	0.1mV	0.001V	0.1mV	0.001V	0.1mV	0.01mV(1061) 0.001mV(1062)	0.001V	0.001V
DCA DC A	250mA	300mA	-	-	10A	-	10A	10A	10A	10A	60A(2000A) 100A(2001A)	120A	
ACA AC A	-	-	-	-	10A	-	10A	10A	10A	10A	60A(2000A) 100A(2001A)	120A	
DC+AC DC+AC	-	-	-	-	-	-	-	-	-	✓	-	-	
Resistance Ω	20MΩ	300KΩ	40MΩ	40MΩ	40MΩ	40MΩ	40MΩ	60MΩ	60MΩ	50MΩ	34MΩ	60MΩ	
Continuity buzzer	-	✓	✓	✓	✓	✓	✓	✓	✓	✓	✓	✓	
Battery test	-	✓	-	-	-	-	-	-	-	-	-	-	
Diode test	-	-	-	✓	✓	✓	✓	✓	✓	✓	-	✓	
Capacitance	-	-	600μF	1000μF	1000μF	100μF	100μF	4000μF	1000μF	50mF	-	40μF	
Frequency Hz	-	-	-	ACV 99.99kHz	ACA 9.999kHz ACV 99.99kHz	200kHz	10MHz	10MHz	99.99kHz	99.99kHz	ACA 10kHz ACV 300kHz	ACA 400Hz ACV 300kHz	
Duty cycle ratio DUTY	-	-	-	✓	✓	✓	✓	✓	-	✓	-	-	
Temperature °C	-	✓	-	-	-	-	-	(1011)	✓	✓	-	-	
Decibel dB	✓	-	-	-	-	-	-	-	-	✓	-	-	
Low power-Ω LP-Ω	-	-	-	-	-	-	-	-	-	✓ (1062)	-	-	
Function													
Dual display	-	-	-	-	-	-	-	-	✓	✓	-	-	
Bar graph	-	-	-	-	-	-	-	✓	✓	✓	✓	✓	
Backlight	-	-	-	✓	✓	✓	-	-	✓	✓	-	-	
Data hold DATA HOLD	-	-	-	✓	✓	✓	✓	✓	✓	✓	✓	✓	
Auto hold	-	-	-	-	-	-	-	-	✓	✓	-	-	
Peak hold PEAK HOLD	-	-	-	-	-	-	-	-	-	✓ (1062)	-	-	
Max/Min/Avg Max/Min Avg	-	-	-	(No Avg)	(No Avg)	-	-	(No Avg)	(1052)	✓	-	-	
Relative REL	-	-	✓	✓	✓	✓	✓	✓	✓	✓	-	-	
Manual memory	-	-	-	-	-	-	-	-	✓ (1052)	✓	-	-	
Logging memory	-	-	-	-	-	-	-	-	✓ (1052)	✓	-	-	
Communication USB	-	-	-	-	-	-	-	-	✓ (1052)	✓	-	-	
Other													
Operating temperature	0 - 40°C	0 - 40°C	0 - 40°C	0 - 40°C	0 - 40°C	0 - 40°C	0 - 40°C	0 - 40°C	-10 - 55°C	-20 - 55°C	0 - 40°C	0 - 40°C	
Measurement categories	-	CAT III 300V CAT II 600V	CAT III 300V CAT II 600V	CAT IV 300V CAT III 600V CAT II 1000V	CAT IV 300V CAT III 600V	CAT III 600V	CAT III 300V	CAT III 300V CAT II 600V	CAT IV 600V CAT III 1000V	CAT IV 600V CAT III 1000V	CAT III 300V CAT II 600V	CAT III 300V CAT II 600V	
Power source	R6 × 2, 6F22 × 1	R6 × 2	CR2032 × 1	R03 × 2	R03 × 2	LR44 × 2	R6 × 2	R6 × 2	R6 × 4	R6 × 4	R03 × 2	R03 × 2	
Dimension (L)x(W)x(D)mm	150×100×47	140×94×39	126×85×18	155×75×40*2	155×75×35*1 155×75×40*2	190×39×31	161×82×50	161×82×50	192×90×49	192×90×49	128×84×24(2000A) 128×92×27(2001A)	128×92×27	
Weight(Approx.)	330g	280g	135g	250g	250g	100g	280g	280g	560g	560g	210g(2000A) 220g(2001A)	220g	
Accessories	Test leads	7066A	7066A	-	7066A	7066A	-	7066A	7066A 8216(1011)	7220A	7220A	-	
	Fuse	8901 × 2	8923 × 2	-	-	8919 × 1	-	8919 × 1 8923 × 1	8918 × 1 8919 × 1	8926 × 1 8927 × 1	8926 × 1 8927 × 1	-	
	Case	-	9103	9188	-	9097	9130	-	-	-	-	-	

*1 With flat-type holder

*2 With wing-type holder

MULTIMETERS



KEW 1020R/1021R



- Accurate reading with True RMS
- Large display with 6000 counts and Backlight
- MIN/MAX function
- Rugged and reliable
- Enhanced current measuring function using an external clamp sensor
- Sensor mode (with clamp sensor)
- Ergonomic design
- Safety Standard IEC 61010-1 CAT IV 300V / CAT III 600V (1020R and 1021R) / CAT II 1000V (1020R)



photo : 1020R

photo : 1021R

	1020R	1021R
DC V	6.000/60.00/600.0/1000V(Auto-ranging) ±0.5%rdg±3dgt(6/60/600V) ±0.8%rdg±3dgt(1000V)	6.000/60.00/600.0V(Auto-ranging) ±0.5%rdg±3dgt
DC mV	600.0mV ±1.5%rdg±3dgt	
DC Clamp Sensor	60.00/200.0A(Auto-ranging) ±1.5%rdg±3dgt + Sensor accuracy	
AC V	6.000/60.00/600.0/1000V(Auto-ranging) ±1.0%rdg±3dgt [40 - 500Hz] (6/60/600V) ±1.3%rdg±3dgt [40 - 500Hz] (1000V)	6.000/60.00/600.0V(Auto-ranging) ±1.0%rdg±3dgt [40 - 500Hz]
AC mV	600.0mV ±2.0%rdg±3dgt [40 - 500Hz]	
AC Clamp Sensor	60.00/200.0A(Auto-ranging) ±2.0%rdg±3dgt + Sensor accuracy [40 - 500Hz]	
DC A	—	6.000/10.00A(Auto-ranging) ±1.5%rdg±3dgt
AC A	—	6.000/10.00A(Auto-ranging) ±1.5%rdg±3dgt [40 - 500Hz]
Ω	600.0Ω/6.000/60.00/600.0kΩ/6.000/40.00MΩ (Auto-ranging) ±0.5%rdg±5dgt(600Ω), ±0.5%rdg±2dgt(6/60/600kΩ/6MΩ), ±1.5%rdg±3dgt(40MΩ)	
Continuity buzzer	600Ω (Buzzer sounds below 90Ω)	
Diode test	Open circuit voltage:<3.0V	
Capacitance	60.00/600.0nF/6.000/60.00/600.0/1000μF ±2.0%rdg±5dgt(60/600nF), ±5%rdg±5dgt(6/60/600/1000μF)	
Frequency	ACV 99.99/999.9Hz/9.999/99.99kHz ±0.1%rdg±3dgt ACA 99.99/999.9Hz/9.999kHz ±0.1%rdg±3dgt*1	
DUTY	10.0 - 90.0% ±1.0%rdg±3dgt [50/60Hz]	
Applicable Standards	IEC 61010-1 CAT IV 300V / CAT III 600V / CAT II 1000V *2 Pollution degree 2, IEC 61010-2-033, IEC 61010-031 IEC 61326-2-2(EMC), IEC 60529 IP40	
Power source	R03(AAA)(1.5V) × 2	
Dimension	155(L) × 75(W) × 40(D) mm (with Wing-type holder)	
Weight	Approx. 250g (including batteries and Wing-type holder)	
Accessories	Wing-type holder 7066A(Test leads) R03(AAA) × 2, Instruction manual	Wing-type holder, Flat-type holder, 7066A(Test leads) 9097(Carrying case), 8919(Ceramic fuse[10A/600V]) × 1(included) R03(AAA) × 2, Instruction manual
Optional Accessories	7234(Alligator clip), 8161(AC Clamp sensor), 8115(AC/DC Clamp sensor), 9189(Magnet hanger strap)	

*1 1021R only *2 1020R only



Accessories

wing-type Holder

MODEL 7066A
Test leads

Flat-type Holder

MODEL 8919
Ceramic fuse[10A/600V]
(Included)

MODEL 9097
Carrying case

1021R only

Optional Accessories

MODEL 7234
Alligator clip

KEW 8161
AC Clamp sensor

AC MAX 100A 024

MODEL 9189
Magnet hanger strap

KEW 8115
AC/DC Clamp sensor

AC MAX 130A 012
DC MAX 180A

MULTIMETERS



MODEL 1009

DC V AC V DC A AC A Ω \rightarrow \leftarrow \rightarrow \leftarrow
 Hz DUTY DATA HOLD REL AUTO POWER OFF

- Display : 3999 counts
- Auto-ranging and manual ranging selector provided (with range hold feature)
- Resistance range provides audible continuity test
- Automatically turns power off in about 30 minutes to conserve battery life
- Direct current measurement up to 10A AC and DC



KEW 1011/1012

1012
 TRUE RMS DC V AC V DC A AC A Ω \rightarrow \leftarrow \rightarrow \leftarrow
 1011
 \rightarrow \leftarrow Hz DUTY $^{\circ}$ C DATA HOLD MAX/MIN
 REL AUTO POWER OFF

- 6040 counts with Bar Graph display
- MIN/MAX function enables to record min & max value
- REL(relative value) function
- Temperature measurement, selectable for $^{\circ}$ C and $^{\circ}$ F (1011 only)
- True RMS can measure and indicate distorted waveforms (1012 only)
- DUTY measurement function



photo : 1012

	1009	1011	1012
DC V	400mV/4/40/400/600V $\pm 0.6\%$ rdg ± 4 dgt*	600.0mV/6.000/60.00/600.0/600V $\pm 0.5\%$ ± 2 dgt*	
AC V	400mV/4/40/400/600V $\pm 1.3\%$ rdg ± 4 dgt*	6.000/60.00/600.0/600V $\pm 1.0\%$ ± 3 dgt*	6.000/60.00/600.0/600V $\pm 1.2\%$ ± 3 dgt*
DC A	400/4000 μ A/40/400mA/4/10A $\pm 1.0\%$ rdg ± 4 dgt*	600/6000 μ A/60/600mA/6/10A $\pm 1.2\%$ ± 3 dgt*	
AC A	400/4000 μ A/40/400mA/4/10A $\pm 2.0\%$ rdg ± 4 dgt*	600/6000 μ A/60/600mA/6/10A $\pm 1.5\%$ ± 4 dgt*	
Ω	400/4/40/400k/4/40M Ω $\pm 1.0\%$ rdg ± 4 dgt	600/6/60/600k/6/60M Ω $\pm 1.0\%$ ± 2 dgt*	
Continuity buzzer	0 - 400 Ω (Buzzer sounds below 100 Ω)	0 - 600 Ω (Buzzer sounds below 100 Ω)	
Diode test	1.5V open circuit voltage : Approx. 0.4mA test current	2.8V open circuit voltage : Approx. 0.4mA test current	
Capacitance test	40/400nF/4/40/100 μ F	40/400nF/4/40/4000 μ F	
Frequency	5.12/51.2/512Hz/5.12/51.2/512kHz/5.12/10MHz	10/100/1000Hz/10/100/1000kHz/10MHz	
DUTY	0.1 - 99.9%(Pulse width/Pulse period) $\pm 2.5\%$ ± 5 dgt	0.1 - 99.9%(Pulse width/Pulse period) $\pm 2.0\%$ ± 2 dgt(- 10kHz)	
Temperature	—	-50 - 300 $^{\circ}$ C(-58 - 572 $^{\circ}$ F)(with the use of Temperature probe 8216)	—
Applicable Standards	IEC 61010-1 CAT III 300V, IEC 61326-1	IEC 61010-1 CAT III 300V / CAT II 600V, IEC 61326	
Power source	R6(AA)(1.5V) \times 2 (Auto power off : Approx. 30 minutes)	R6(AA)(1.5V) \times 2 (Auto power off : Approx. 15 minutes)	
Dimension	161(L) \times 82(W) \times 50(D)mm	161(L) \times 82(W) \times 50(D)mm	
Weight	Approx. 280g	Approx. 280g	
Accessories	7066A(Test leads), 8919(Ceramic fuse[10A/600V]) \times 1 (included), 8923(Fuse [0.5A/600V]) \times 1 (included), R6(AA) \times 2, Instruction manual	7066A(Test leads), 8216(K-type temperature probe)(1011 only), 8918(Ceramic fuse[0.8A/600V]) \times 1 (included), 8919(Ceramic fuse[10A/600V]) \times 1 (included), R6(AA) \times 2, Instruction manual	
Optional Accessories	7234(Alligator clip), 9095(Carrying case)		

*Basic accuracy : For the detailed accuracy, please see our product catalog on our website.



KEW 1109S

DC V AC V DC A AC A Ω dB

- Mirrored scale for easy and accurate reading
- Output terminal to cut off DC component when measuring AC voltage
- Safety designed input terminals and test leads

	1109S
DC V	0.1/0.5/2.5/10/50/250/1000V(20k Ω /V) $\pm 3\%$ of FS
AC V	10/50/250/1000V(9k Ω /V) $\pm 3\%$ of FS
DC A	50 μ A/2.5/25/250mA $\pm 3\%$ of FS
Ω	2/20k Ω /2/20M Ω $\pm 3\%$ of scale length
Decibel	-10 - +62dB
hFE	0 - 1000(Ω \times 10) $\pm 3\%$ of scale length
Power source	R6(AA)(1.5V) \times 2, 6F22(9V) \times 1
Dimension	150(L) \times 100(W) \times 47(D)mm
Weight	Approx. 330g
Accessories	7066A(Test leads), 8901(Fuse[0.5A/250V]) \times 1 (included), 1 (spare) R6(AA) \times 2, 6F22 \times 1, Instruction manual
Optional Accessories	9168(Carrying case)

Do not make voltage measurements on industry power lines of 250V or higher.



MODEL 1110

DC V AC V DC A AC A Ω \rightarrow \leftarrow $^{\circ}$ C

- High sensitivity DC20k Ω /V
- 1m drop-proof heavy duty design
- Can measure line voltage up to AC 600V (Voltage to ground MAX AC 300V) (Protected by 600V ceramic fuse against accidental overload)
- Continuity buzzer, battery check, LED check function
- Skeleton type robust and clear case with carrying handle furnished as standard accessory

	1110
DC V	0.3V(16.7k Ω /V) $\pm 3\%$ of FS 3/12/30/120/300/600V(20k Ω /V) $\pm 3\%$ of FS
AC V	12V(9k Ω /V) $\pm 4\%$ of FS 30/120/300/600V(9k Ω /V) $\pm 3\%$ of FS
DC A	60 μ A/30/300mA $\pm 3\%$ of FS
Ω	3/30/300k Ω $\pm 3\%$ of scale length
Continuity buzzer	Buzzer sounds below 100 Ω
Battery Test	1.5V(0.7 - 2V) $\pm 3\%$ of FS (10 Ω load)
Temperature	Possible with the temperature probe 7060 (discontinued).
LED	Approx. 10mA at 0 Ω (at 3V of battery voltage)
Applicable Standards	IEC 61010-1 CAT III 300V / CAT II 600V, IEC 61326-1
Power source	R6(AA)(1.5V) \times 2
Dimension	140(L) \times 94(W) \times 39(D)mm
Weight	Approx. 280g
Accessories	7066A(Test leads), 8923(Fuse[0.5A/600V]) \times 1 (included), 1 (spare) R6(AA) \times 2, 9103(Carrying case), Instruction manual



DIGITAL MULTIMETERS

KEW 1019R



TRUE RMS DC AC V Ω ()) () REL AUTO POWER SAVE

- True RMS Measurements
- Large display
- Sturdy test leads
- Simple range composition
- Smart structure hard case
- DCV, ACV, Ω, Capacitance Measurement
- Complies with IEC 61010-1 CAT III 300V / CAT II 600V

	1019R
DC V	600.0mV/6.000/60.00/600.0V(Input impedance :10MΩ) ±0.8%rdg±5dgt(600.0mV/6.000/60.00V) ±1.0%rdg±5dgt(600.0V)
AC V	6.000/60.00/600.0V(Input impedance:10MΩ) ±1.3%rdg±5dgt(6.000/60.00V)(50/60Hz) ±1.7%rdg±5dgt(6.000/60.00V)(45 - 500Hz) ±1.6%rdg±5dgt(600.0V)(50/60Hz) ±2.0%rdg±5dgt(600.0V)(45 - 500Hz)
Ω	600.0Ω/6.000/60.00/600.0kΩ/6.000/40.00MΩ ±1.0%rdg±5dgt(600.0Ω/6.000/60.00/600.0kΩ/6.000MΩ) ±2.5%rdg±5dgt(40.00MΩ)
Continuity buzzer	600Ω(Buzzer sounds below 60Ω)
Capacitance test	6.000/60.00/600.0nF/6.000/60.00/600.0μF ±3.5%rdg±5dgt(6.000nF) ±3.5%rdg±10dgt(60.00nF) ±3.5%rdg±5dgt(600.0nF/6.000/60.00μF) ±4.5%rdg±5dgt(600.0μF)
Applicable Standards	IEC 61010-1 CAT III 300V / CAT II 600V IEC 61010-2-033, IEC 61010-031, IEC 61326-2-2
Power source	CR2032(3V) × 1 (Auto power save : Approx. 15 minutes)
Dimension	126(L) × 85(W) × 18(D)mm (including hard case)
Weight	Approx. 135g (including battery and hard case)
Accessories	9188(Hard case), CR2032 × 1, Instruction manual

Retractable Case Cover

2Way Test Probe Holder

Cap Holder

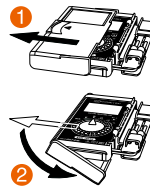

with Caps : CAT III
without Caps : CAT II

KEW 1030



DC AC V Ω ()) () Hz DUTY () DATA HOLD REL AUTO POWER OFF

- Compact, lightweight, easy to use
- Double molding provides comfortable and good feeling in hand
- Penlight illuminates brightly the point to be measured, even in dark place
- Backlight LCD is highly visible, even in darkness
- Test lead is wrapped in its rear side compartment without difficulty

	1030
DC V	400mV/4/40/400/600V(5 range auto) ±0.8%rdg±5dgt(400mV - 400V) ±1.0%rdg±5dgt(600V)
AC V	4/40/400/600V(4 range auto) ±1.3%rdg±5dgt(4/40V)(50/60Hz) ±1.6%rdg±5dgt(400/600V) (50/60Hz)
Ω	400Ω/4/40/400kΩ/4/40MΩ(6 range auto) ±1.0%rdg±5dgt(400Ω - 4MΩ) ±2.5%rdg±5dgt(40MΩ)
Continuity buzzer	Buzzer sounds when resistance is 120Ω or less.
Diode test	Test voltage approx. 0.3 - 1.5V
Capacitance test	50/500nF/5/50/100μF(5 range auto) ±3.5%rdg±10dgt(50nF) ±3.5%rdg±5dgt(500n - 50μF) ±4.5%rdg±5dgt(100μF)
Frequency	5/50/500Hz/5/50/200kHz ±0.1%rdg±5dgt
Duty	0.1 - 99.9% ±2.5%rdg±5dgt (Pulse width / Pulse cycle)
Applicable Standards	IEC 61010-1 CAT III 600V IEC 61010-031, IEC 61326-1(EMC)
Power source	Button type battery LR44(SR44)(1.5V) × 2 (Auto power off : Approx. 30 minutes)
Dimension	190(L) × 39(W) × 31(D)mm
Weight	Approx. 100g (including batteries)
Accessories	9130(Carrying case), LR44 × 2, Instruction manual

Protection cover prevents unforeseen accident



Pull up and turn, then, cover

Test lead is wrapped in its rear side compartment without difficulty



Release test lead from holder.

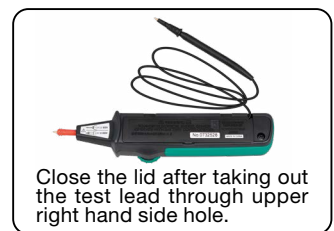

Close the lid after taking out the test lead through upper right hand side hole.

DIGITAL MULTIMETERS

DIGITAL MULTIMETERS



photo : 1052



photo : 1062

KEW 1051/1052 KEW 1061/1062

TRUE RMS CAT IV 600V DC V DC AC DC+AC Ω LP-Ω Hz DUTY °C dB DATA HOLD PEAK HOLD MAX/MIN AVG REL Filter

1061,1062 1062 1062 Except for 1051 Except for 1061

Except for 1051 USB AUTO POWER OFF

- True RMS or MEAN value detection mode can be selected (1052 and 1062 only)
- DC+AC TRMS Measurement (1061 and 1062 only)
AC and DC values are displayed simultaneously via dual display
- Fast Peak Hold response time of 250µs (1062 only)
- Low-pass filter except for 1061
- Low Power-Ω measurements (1062 only)
- User calibration function

Safety design for industrial use

- Complies with IEC 61010-1 CAT IV 600V / CAT III 1000V
- Terminal shutter to prevent incorrect test leads insertion in current terminals
- Very wide operating temperature range
From -20 to +55°C for 1061/1062
From -10 to +55°C for 1051/1052

Comprehensive support for data management except for 1051

- Large data internal memory
- Download data and Live Monitoring on a PC via the USB interface (Option for USB Communication set)



High Accuracy, High Performance and Reliable Measurements

- Top accuracy
0.02% basic DC accuracy for 1061/1062
0.09% basic DC accuracy for 1051/1052
- Dual display
1061/1062: 50,000 counts, 51 segments bar graph with white backlight display
1051/1052: 6,000 counts, 31 segments bar graph with white backlight display
- True RMS Measurements
- Wide AC Frequency bandwidth from 10Hz to 100kHz (1062 only)

	1051	1052	1061	1062
Detection mode	True RMS	MEAN/True RMS (switch)	True RMS	MEAN/True RMS (switch)
DC V	600.0mV/6.000/60.00/600.0/1000V (Input impedance: 10MΩ [600mV/60/600/1000V], 11MΩ [6V]) ±0.09%rdg±2dgt *		50.000/500.00/2400.0mV/5.0000/50.000/500.00/1000.0V (Input impedance: Approx. 100MΩ [50/500/2400mV], 10MΩ [5/50/500/1000V]) ±0.02%rdg±2dgt *	
AC V [True RMS]	600.0mV/6.000/60.00/600.0/1000V (Input impedance: 10MΩ<200pF [600mV], 11MΩ<50pF [6V], 10MΩ<50pF [60/600/1000V]) ±0.5%rdg±5dgt *		50.000*1/500.00mV/5.0000/50.000/500.00/1000.0V (Input impedance: 11MΩ<50pF [50/500mV/5V], 10MΩ<50pF [50/500/1000V]) ±0.7%rdg±30dgt *	±0.4%rdg±30dgt *
AC V [MEAN]	-	600.0mV/6.000/60.00/600.0/1000V (Input impedance: 10MΩ<200pF [600mV], 11MΩ<50pF [6V], 10MΩ<50pF [60/600/1000V]) ±0.5%rdg±5dgt *	-	50.000/500.00mV/5.0000/50.000/500.00/1000.0V (Input impedance: 11MΩ<50pF [50/500mV/5V], 10MΩ<50pF [50/500/1000V]) ±1%rdg±30dgt *
DCV+ACV	-	-	5.0000/50.000/500.00/1000.0V (Input impedance: 11MΩ<50pF [5V], 10MΩ<50pF [50/500/1000V]) ±1%rdg±10dgt *	±0.5%rdg±10dgt *
DC A	600.0/6000µA/60.00/440.0mA/6.000/10.00A ±0.2%rdg±2dgt *		500.00/5000.0µA/50.000/500.00mA/5.0000/10.000A ±0.2%rdg±5dgt *	
AC A [True RMS]	600.0/6000µA/60.00/440.0mA/6.000/10.00A ±0.75%rdg±5dgt *		500.00/5000.0µA/50.000/500.00mA/5.0000/10.000A ±1%rdg±20dgt *	±0.75%rdg±20dgt *
AC A [MEAN]	-	-	-	500.00/5000.0µA/50.000/500.00mA/5.0000/10.000A ±1.5%rdg±20dgt *
DCA+ACA	-	-	500.00/5000.0µA/50.000/500.00mA/5.0000/10.000A ±1.5%rdg±10dgt *	±1%rdg±10dgt *
Ω	600.0Ω/6.000/60.00/600.0kΩ/6.000/60.00MΩ ±0.4%rdg±1dgt *		500.00Ω/5.0000/50.000/500.00kΩ/5.0000/50.000MΩ ±0.1%rdg±2dgt *	±0.05%rdg±2dgt *
LowPower-Ω	-	-	-	5.000/50.00/500.0kΩ/5.000MΩ ±0.2%rdg±3dgt *
Continuity buzzer	600.0Ω (The buzzer turns on at resistances lower than 50±30Ω)		500.0Ω (The buzzer turns on at resistances lower than 100±50Ω)	
Diode test	2.000V ±1%rdg±2dgt Open circuit voltage: <3.5V (Approx. 0.5mA Measuring Current)		2.4000V ±1%rdg±2dgt Open circuit voltage: <5V (Approx. 0.5mA Measuring Current)	
Capacitance	10.00/100.0nF/1.000/10.00/100.0/1000µF ±2%rdg±5dgt *		5.000/50.00/500.0nF/5.000/50.00/500.0µF/5.000/50.00mF ±1%rdg±5dgt *	
Frequency	10.00 - 99.99/90.0 - 999.9Hz/0.900 - 9.999/9.00 - 99.99kHz ±0.02%rdg±1dgt *		2.000 - 9.999/9.00 - 99.99/90.0 - 999.9Hz/0.900 - 9.999/9.00 - 99.99kHz ±0.02%rdg±1dgt *	
DUTY	-	-	10 - 90% ±1%rdg	
Temperature	-50 - 600°C ±2%rdg±2°C (with the use of K-type Temperature probe)		-200 - 1372°C ±1%rdg±1.5°C (with the use of K-type Temperature probe)	
Applicable Standards	IEC 61010-1 CAT IV 600V / CAT III 1000V Pollution degree 2, IEC 61326-1 (EMC)			
Power source	R6/LR6(1.5V) × 4 (Auto power off: Approx. 20 minutes)			
Dimension	192(L) × 90(W) × 49(D) mm			
Weight	Approx. 560g (including batteries)			
Accessories	7220A (Test Leads), 8926(Fuse [440mA/1000V]) × 1 (included), 8927(Fuse [10A/1000V]) × 1 (included), LR6 × 4, Instruction manual			

*1 1062 only

*Basic accuracy : For the detailed accuracy, please see our product catalog on our website.

DIGITAL MULTIMETERS

Comprehensive support for data management

※ except for 1051

Large internal memory to store test data

- 1062: 10,000 data in Logging mode, 100 data manually saved.
- 1061: 1,000 data in Logging mode, 100 data manually saved.
- 1052: 1,600 data in Logging mode, 100 data manually saved.
- Logging interval can set from 1 sec. to 30 min.

Test data can be transferred to a PC or directly to a Printer*

- Real-time data can be transferred and shown on a PC.
- Real-time transferring permits the saving of a considerable amount of data on a PC.
- Stored data of internal memory can be monitored by PC.

Data management with the software DMM Application*

- Stored data of internal memory can be monitored by PC.
- List of measured data can be converted into Graph.
- Data can be transferred to Excel** and saved as CSV file.

*Optional accessories are required.

**Excel is a registered trademark of Microsoft in the US.

Data analysis with Excel

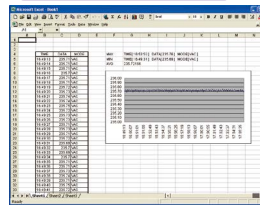

Printer output

L0000 N+12.539 VDC
L0001 N+12.532 VDC
L0002 N+12.532 VDC
L0003 N+12.529 VDC
L0004 N+12.532 VDC
L0005 N+12.538 VDC
L0006 N+12.541 VDC
L0007 N+12.546 VDC
L0008 N+12.552 VDC
L0009 N+12.557 VDC
L0010 N+12.555 VDC
L0011 N+12.554 VDC
L0012 N+12.553 VDC

Printed items (from the left)

- L: Logging memory
- 4 digit numbers: Data number
- N: Normal measurement
- (O: at "OL" display)
- (B: at "Battery warning" display)
- 5 digit numbers: Measurement
- VDC: Unit (VDC is DC Voltage)



DMM Application software

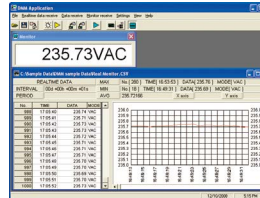

System requirements

- OS: Windows® 11/10
- Display: XGA (Resolution 1024 × 768 dots) or more
- Required HDD space: 10Mbyte or more
- Others: With CD-ROM drive and USB port

* Windows® is a registered trademark of Microsoft in the United States.

Optional Accessories

Description	MODEL	Contents
Alligator Clip	7234	CAT IV 600V / CAT III 1000V 1set
USB Communication set	8241	USB adapter+USB cable+DMM Software
Thermocouple Type K	8405	-40 - 500°C (Surface type, Point material: Ceramic)
	8406	-40 - 500°C (Surface type)
	8407	-40 - 700°C (Liquid, Semi-solid)
	8408	-40 - 600°C (Air, Gas)
Clamp sensor	8115	AC 130A/DC 180A
	8121	AC 100A
	8122	AC 500A
	8123	AC 1000A
	8146	AC 30A
	8147	AC 70A
	8148	AC 100A
Banana φ4mm Adjuster Plug	7146	Length :190mm
Carrying case	9154	Soft case(for the main unit with test leads and communication cable)

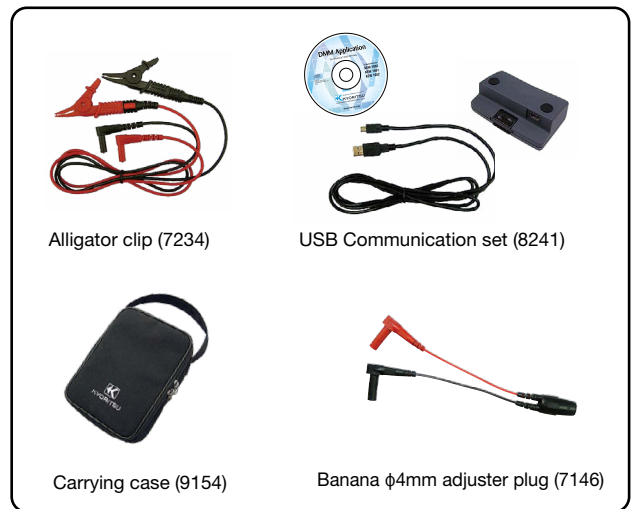

Thermocouple Type K Specification

MODEL	Usage	Measurement temperature	Tolerance (°C) (t: Measured temperature)	Response speed
8405	Surface type (Point material: Ceramic)	-40 - 500°C	±2.5 °C (-40 - 332°C), ±0.0075 × t (333 - 500°C)	Approx. 1.8 sec.
8406				Approx. 1.0 sec.
8407	Liquid, Semi-solid	-40 - 700°C	±2.5 °C (-40 - 332°C), ±0.0075 × t (333 - 700°C)	1 sec. or less
8408	Air, Gas	-40 - 600°C	±2.5 °C (-40 - 332°C), ±0.0075 × t (333 - 600°C)	0.4 sec.

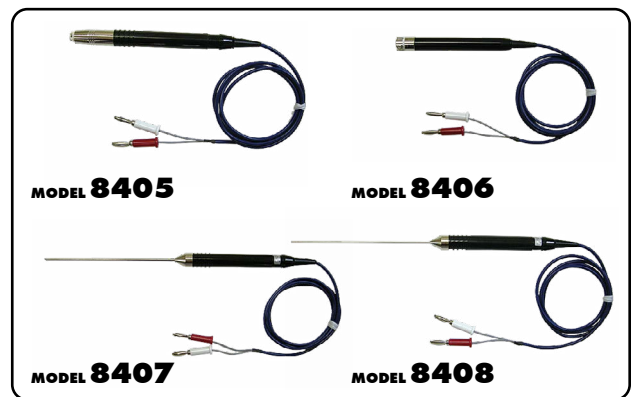

Clamp sensor Specification

	AC/DC current sensor	AC current sensor				Leakage & AC current sensor		
	8115	8121*	8122*	8123*	8146*	8147*	8148*	
Appearance								
Conductor size	φ12mm	φ24mm	φ40mm	φ55mm	φ24mm	φ40mm	φ68mm	
Rated current	AC 130A / DC 180A	AC 100A	AC 500A	AC 1000A	AC 30A	AC 70A	AC 100A	
Output voltage	AC 10mV/A, DC 10mV/A	AC 500mV/100A	AC 500mV/500A	AC 500mV/1000A	AC 1500mV/30A	AC 3500mV/70A	AC 5000mV/100A	
Accuracy (50/60Hz)	AC ±1.2%rdg±0.4mV DC ±1.2%rdg±0.4mV (This accuracy is defined after zero adjustment)	±2.0%rdg±0.3mV			0 - 15A ±1.0%rdg±0.1mV 15 - 30A ±5.0%rdg	0 - 40A ±1.0%rdg±0.1mV 40 - 70A ±5.0%rdg	0 - 80A ±1.0%rdg±0.1mV 80 - 100A ±5.0%rdg	
Frequency range	40Hz - 1kHz							
Dimension	127(L)×42(W)×22(D)mm	97(L)×59(W)×26(D)mm	128(L)×81(W)×36(D)mm	170(L)×105(W)×48(D)mm	100(L)×60(W)×26(D)mm	128(L)×81(W)×36(D)mm	186(L)×129(W)×53(D)mm	
Weight	Approx. 160g	Approx. 150g	Approx. 260g	Approx. 360g	Approx. 150g	Approx. 240g	Approx. 510g	

*Banana φ4mm adjuster plug(7146) is required to connect the clamp sensor to the DMM.

DIGITAL MULTIMETERS

DIGITAL MULTIMETERS

KEW MATE 2000A

Ø6

MAX 60A

KEW MATE 2001A

Ø10

MAX 100A

KEW MATE 2012RA

Ø12

MAX 120A

TRUE RMS

→

←



- Capable of measuring AC and DC currents with OPEN CLAMP SENSOR 60A(2000A)/100A(2001A)/120A(2012RA)
- Cable strength increased with robust cable protection
- Test probe can be fixed to the holster
- Can measure AC/DC current and voltage
- Pocket size and heavy duty design
- Test lead cap to protect from short circuit accident
- The open jaws are thin, perfect to clamp wires even in tight spaces

DC V AC V DC A AC A Ω Hz DATA HOLD AUTO POWER SAVE



photo : 2012RA



Robust cable protection



photo : 2000A



photo : 2001A



	2000A	2001A	2012RA
DC V	340.0mV/3.400/34.00/340.0/600V (input impedance : Approx. 10MΩ) ±1.5%rdg±4dgt		600.0mV/6.000/60.00/600.0V (input impedance : Approx. 10MΩ) ±1.0%rdg±3dgt
AC V	3.400/34.00/340.0/600V (input impedance : Approx. 10MΩ) ±1.5%rdg±5dgt (50 - 400Hz)		6.000/60.00/600.0V (input impedance : Approx. 10MΩ) ±1.5%rdg±5dgt (45 - 400Hz)
DC A	60.0A ±2.0%rdg±5dgt	100.0A ±2.0%rdg±5dgt	60.00/120.0A ±2.0%rdg±8dgt (60A) ±2.0%rdg±5dgt (120A)
AC A	60.0A ±2.0%rdg±5dgt (50/60Hz)	100.0A ±2.0%rdg±5dgt(50/60Hz)	60.00/120.0A ±2.0%rdg±5dgt (45 - 65Hz)
Ω	340.0Ω/3.400/34.00/340.0kΩ/3.400/34.00MΩ ±1.0%rdg±3dgt (340Ω/3.4/34/340kΩ) ±5.0%rdg±5dgt (3.4MΩ) ±15.0%rdg±5dgt (34MΩ)		600.0Ω/6.000/60.00/600.0kΩ/6.000/60.00MΩ ±1.0%rdg±5dgt (600Ω/6/60/600kΩ) ±2.0%rdg±5dgt (6MΩ) ±3.0%rdg±5dgt (60MΩ)
Continuity buzzer	Buzzer sounds below 30±10Ω (Continuity buzzer works on 340Ω range only)		Buzzer sounds below 35±25Ω
Diode test	-	-	2.000V ±3.0%rdg±5dgt Open circuit voltage : Approx. 2.7V
Capacitance	-	-	400.0nF/4.000/40.00µF ±2.5%rdg±10dgt
Frequency	AC A	3.400/10.00kHz ±0.1%rdg±1dgt	99.99/400.0Hz ±0.2%rdg±2dgt (100Hz) ±0.1%rdg±1dgt (400Hz)
	AC V	3.400/34.00/300.0kHz ±0.1%rdg±1dgt	99.99/999.9Hz/9.999/99.99/300.0kHz ±0.2%rdg±2dgt (100Hz) ±0.1%rdg±1dgt (1000Hz/10/100/300kHz)
	Input sensitivity	Current:more than 15A Voltage:more than 30V	Current:more than 25A Voltage:more than 30V
Conductor size	φ6mm max	φ10mm max	φ12mm max
Applicable standards	IEC 61010-1 CAT III 300V / CAT II 600V Pollution degree 2, IEC 61010-031, IEC 61010-2-032, IEC 61326-1		
Power source	R03(AAA)(1.5V)×2 *Continuous measuring time : Approx. 45hours (Auto power save : Approx. 10minutes)		R03(AAA)(1.5V)×2 *Continuous measuring time: DC V : Approx. 150hours, AC A : Approx. 25hours (Auto power save : Approx. 15minutes)
Dimension	128(L)×87(W)×24(D) mm	128(L)×92(W)×27(D) mm	
Weight	Approx. 210g (including batteries)	Approx. 220g (including batteries)	
Accessories	R03(AAA)×2, Instruction manual		
Optional Accessories	9107(Soft case)		



Test Probe can be fixed to the holster



Forklift maintenance



Automobile maintenance

CLAMP METERS



CLAMP METERS

Selection Guide of Clamp Meters

Selection Guide of Clamp Meters												
	AC Clamp Meters											Fork Current Tester
	2031	2007R	2117R	2127R	2200	2200R	2002PA	2002R	2204R	2210R	2300R	
Appearance												
Conductor size	φ24mm	φ33mm	φ33mm	φ33mm	φ33mm	φ33mm	φ55mm	φ55mm	φ70mm	φ150mm	φ10mm	
Display	Digital	Digital	Digital	Digital	Digital	Digital	Digital	Digital	Digital	Digital	Digital	
Detection method	-	✓	✓	✓	-	✓	-	✓	✓	✓	✓	
Frequency response	40Hz - 1kHz	40 - 400Hz	40Hz - 1kHz	40Hz - 1kHz	45 - 65Hz(ACA) 45 - 500Hz(ACV)	40Hz - 1kHz(ACA) 45 - 500Hz(ACV)	40Hz - 1kHz	40Hz - 1kHz	45 - 500Hz	45 - 500Hz	DC 50/60Hz	
Measurement												
AC A	Max	200A	1000A	1000A	1000A	1000A	1000A	2000A	2000A	400A	3000A	100A
	Resolution	0.01A	0.1A	0.01A	0.01A	0.01A	0.01A	0.1A	0.1A	0.001A	0.01A	0.1A
	Accuracy	±2%R±5D	±1.5%R±4D	±1.5%R±4D	±1.5%R±4D	±1.4%R±6D	±1.5%R±5D	±1%R±3D	±1.5%R±3D	±3%R±5D	±3%R±5D	±2%R±5D
DC A	Max	-	-	-	-	-	-	-	-	-	-	100A
	Resolution	-	-	-	-	-	-	-	-	-	-	0.1A
	Accuracy	-	-	-	-	-	-	-	-	-	-	±2%R±5D
AC Voltage AC V	-	600V	600V	600V	600V	600V	750V	750V	-	-	-	
DC Voltage DC V	-	600V	600V	600V	600V	600V	1000V	1000V	-	-	-	
Resistance Ω	-	6kΩ	600kΩ	40MΩ	40MΩ	40MΩ	400KΩ	400KΩ	-	-	-	
Continuity buzzer	-	✓	✓	✓	✓	✓	✓	✓	-	-	-	
Frequency Hz	-	-	-	9.999kHz	-	-	-	-	-	-	-	
Duty cycle ratio DUTY	-	-	-	-	-	-	-	-	-	-	-	
Diode test	-	-	-	✓	-	-	-	-	-	-	-	
Capacitance	-	-	-	✓	-	-	-	-	-	-	-	
Temperature °C	-	-	-	-	-	-	-	-	-	-	-	
Function												
Non contact voltage NCV	-	-	✓	✓	-	-	-	-	-	-	-	✓
Backlight	-	-	-	✓	-	-	-	-	✓	✓	-	
Data hold DATA HOLD	✓	✓	✓	✓	✓	✓	✓	✓	✓	✓	✓	
Peak hold PEAK HOLD	-	-	-	✓	-	-	✓	✓	-	-	-	
Max/Min MAX/MIN	-	-	-	-	-	-	-	-	✓	✓	-	
Relative REL	-	-	-	-	-	-	-	-	-	-	-	
Output OUT PUT	-	-	-	-	-	-	✓	✓	-	-	-	
Other												
Operating temperature	0 - 40°C	0 - 40°C	0 - 40°C	0 - 40°C	0 - 40°C	0 - 40°C	0 - 40°C	0 - 40°C	0 - 50°C	0 - 50°C	0 - 40°C	
Measurement categories	CAT III 300V	CAT IV 300V CAT III 600V	CAT IV 300V CAT III 600V	CAT IV 300V CAT III 600V	CAT III 600V(ACA) CAT III 300V(AC/DCV) CAT II 600V(AC/DCV)	CAT IV 300V(ACA) CAT III 600V(ACA) CAT III 300V(AC/DCV) CAT II 600V(AC/DCV)	CAT III 600V CAT II 1000V	CAT III 600V CAT II 1000V	CAT IV 600V CAT III 1000V	CAT IV 600V CAT III 1000V	CAT III 300V	
Power source	LR44 × 2	R03/LR03 × 2	R03/LR03 × 2	R03/LR03 × 2	R03/LR03 × 2	R03/LR03 × 2	R6 × 2	R6 × 2	R03/LR03 × 2	R03/LR03 × 2	R03 × 2	
Dimension (L)×(W)×(D)mm	147×58.5×26	204×81×36	204×81×36	204×81×36	190×68×20	190×68×20	247×105×49	247×105×49	120×70×26 (Display unit)	120×70×26 (Display unit)	161×40×30	
Weight(Approx.)	100g	220g	220g	230g	120g	120g	470g	470g	200g	300g	110g	
Accessories	Test leads	-	7066A	7066A	7066A	7107A	7107A	7107A	7107A	-	-	-
	Fuse	-	-	-	-	-	-	-	-	-	-	
	Case	9090	9079	9079	9079	9160	9160	9094	9094	9174	9174	9113

CLAMP METERS

Selection Guide of Clamp Meters

	DC Milliamp Clamp Meter/ Clamp Logger		AC/DC Clamp Meters						Leakage Clamp Meters					
	2500	2510	2010	2033	2046R	2055 2056R	2003A	2009R	2431	2434	2432	2433 2433R	2413F 2413R	
Appearance														
Conductor size	φ6 mm	φ6 mm	φ7.5mm	φ24mm	φ33mm	φ40mm	φ55mm	φ55mm	φ24mm	φ28mm	φ40mm	φ40mm	φ68mm	
Display	Digital	Digital	Digital	Digital	Digital	Digital	Digital	Digital	Digital	Digital	Digital	Digital	Digital	
Detection method	-	-	-	-	✓	✓ (2056R)	-	✓	-	-	-	✓ (2433R)	✓ (2413R)	
Frequency response	DC	DC	DC 40Hz - 2kHz	DC 20Hz - 1kHz	DC 40 - 400Hz	DC 40 - 400Hz	DC 40Hz - 1kHz	DC 20Hz - 1kHz	40 - 400Hz	40 - 400Hz	20Hz - 1kHz	20Hz - 1kHz	40Hz - 1kHz	
Measurement														
AC A	Max	-	-	20A	300A	600A	1000A	2000A	2000A	200A	100A	100A	400A	1000A
	Resolution	-	-	0.1mA	0.01A	0.1A	0.1A	0.1A	0.1A	0.01mA	0.1mA	0.001mA	0.01mA	0.1mA
	Accuracy	-	-	±1%R±2D	±1%R±4D	±2%R±5D	±2%R±5D	±1.5%R±2D	±1.3%R±3D	±2%R±4D	±2%R±4D	±1%R±5D	±1%R±5D	±1.8%R±5D(2413F) ±1%R±2D(2413R)
DC A	Max	120mA	120mA	20A	300A	600A	1000A	2000A	2000A	-	-	-	-	-
	Resolution	0.01mA	0.01mA	0.001A	0.01A	0.1A	0.1A	0.1A	0.1A	-	-	-	-	-
	Accuracy	±0.2%R±5D	±0.2%R±5D	±1%R±2D	±1%R±4D	±1.5%R±5D	±1.5%R±5D	±1.5%R±2D	±1.3%R±2D	-	-	-	-	-
AC Voltage AC V	-	-	-	-	600V	600V	750V	750V	-	-	-	-	-	
DC Voltage DC V	-	-	-	-	600V	600V	1000V	1000V	-	-	-	-	-	
Resistance Ω	-	-	-	-	60MΩ	60MΩ	4000Ω	4000Ω	-	-	-	-	-	
Continuity buzzer	-	-	-	-	✓	✓	✓	✓	-	-	-	-	-	
Frequency Hz	-	-	-	-	10kHz	10kHz	-	4000Hz	-	-	-	-	-	
Duty cycle ratio DUTY	-	-	-	-	✓	✓	-	-	-	-	-	-	-	
Diode test	-	-	-	-	✓	✓	-	-	-	-	-	-	-	
Capacitance	-	-	-	-	✓	✓ (2056R)	-	-	-	-	-	-	-	
Temperature °C	-	-	-	-	✓	✓ (2056R)	-	-	-	-	-	-	-	
Function														
Non contact voltage NCV	-	-	-	-	✓	✓	-	-	-	-	-	-	-	
Backlight	✓	✓	-	-	✓	✓	-	-	-	-	-	-	✓ (2413R)	
Data hold DATA HOLD	✓	✓	-	✓	✓	✓	✓	✓	✓	✓	✓	✓	✓	
Peak hold PEAK HOLD	-	-	-	-	✓	✓ (2056R)	✓ (Max)	✓*2	-	-	✓	✓	✓	
Max/Min MAX/MIN	-	-	-	-	✓	✓	-	-	-	-	-	-	-	
Relative REL	-	-	-	-	✓	✓	-	-	-	-	-	-	-	
Output OUT PUT	✓	✓	✓	-	-	-	✓	✓	-	-	-	-	✓	
Filter Filter	-	-	-	-	-	-	-	-	✓	✓	✓	✓	✓	
Other														
Operating temperature	-10 - 50°C	-10 - 50°C	0 - 50°C	0 - 40°C	0 - 40°C	0 - 40°C	0 - 40°C	0 - 40°C	0 - 40°C	0 - 40°C	0 - 40°C	0 - 40°C	0 - 40°C	
Measurement Categories	-	-	-	CAT III 300V	CAT IV 600V	CAT IV 600V	CAT IV 600V CAT III 1000V	CAT IV 600V CAT III 1000V	CAT III 300V	CAT III 300V	CAT III 300V	CAT III 300V	CAT III 300V	
Power source	R6/LR6 × 4	R6/LR6 × 4*1	6LR61 × 1	LR44 × 2	R03 × 2	R03 × 2	R6 × 2	R6 × 2	LR44 × 2	R03 × 2	R03 × 2	R03 × 2	6F22 × 1	
Dimension (L)x(W)x(D)mm	111×61×40 (Display unit) 104×34×20 (Sensor)	111×61×46 (Display unit) 104×34×20 (Sensor)	142×64×26 (Display unit) 153×23×18 (Sensor)	147×59×25	243×77×36	254×82×36	250×105×49	250×105×49	149×60×26	169×75×40	185×81×32	185×81×40	250×130×50	
Weight(Approx.)	290g	310g	220g	100g	300g	310g	530g	540g	120g	220g	290g	270g	570g(2413F) 600g(2413R)	
Accessories	Test leads	-	-	-	7066A	7066A	7107A	7107A	-	-	-	-	-	
	Case	9096	9096	9095	9090	9094	9094	9094	9090	9097	9097	9097	9094	

*1 External power is available.

*2 In the PEAK mode, the auto-ranging feature is disabled and measuring ranges are fixed as follows.

DC/ ACA : 0 - 400.0A

DC/ ACV : 0 - 400.0V

DIGITAL AC CLAMP METERS



CE

KEW 2007R

TRUE RMS Ø33 MAX 1000A AC A DC V Ω
DATA HOLD AUTO POWER SAVE

- Fully Safety jaw
- Ergonomic over-molded body gives convenient one-hand operation
- Large easy-to-read display with 0.1A resolution
- Accurate reading with True RMS 600/1000A auto-ranging
- Long battery life
- Safety Standard IEC 61010-1 CAT IV 300V / CAT III 600V

	2007R
AC A	600.0/1000A(Auto-ranging) ±1.5%rdg±4dgt[45 - 65Hz] ±2.0%rdg±4dgt[40 - 400Hz]
AC V	600.0V ±1.2%rdg±3dgt[45 - 65Hz] ±1.5%rdg±4dgt[40 - 400Hz]
DC V	600.0V ±1.2%rdg±3dgt
Ω	600.0Ω/6.000kΩ(Auto-ranging) ±1.3%rdg±5dgt[600Ω] ±2.0%rdg±3dgt[6.000kΩ]
Continuity buzzer	600Ω(Buzzer sounds below 90Ω)
Conductor size	φ33mm max.
Applicable Standards	IEC 61010-1 CAT IV 300V / CAT III 600V Pollution degree 2 IEC 61010-031, IEC 61010-2-032, IEC 61010-2-033 IEC 61326-2-2(EMC), IEC 60529 IP40
Power source	R03/LR03(AAA)(1.5V) × 2 *Continuous measuring time : Approx. 170 hours (when R03 is used) (Auto power save : Approx. 10 minutes)
Dimension	204(L) × 81(W) × 36(D)mm
Weight	Approx. 220g (including batteries)
Accessories	7066A(Test leads), 9079(Carrying case) R03(AAA) × 2, Instruction manual

MODEL 2002PA/2002R



CE

2002R
TRUE RMS Ø55 MAX 2000A AC A DC V Ω
DATA HOLD PEAK HOLD OUT PUT AUTO POWER SAVE

- Can measure large AC current up to 2000A
- Peak hold function
- 55mm large tear drop shaped jaws
- Minimum resolution 0.1A

photo : 2002R

	2002PA	2002R
AC A	400A(0 - 400A) ±1%rdg±3dgt[50/60Hz] ±2%rdg±3dgt[40Hz - 1kHz] 2000A(0 - 1500A) ±1%rdg±3dgt[50/60Hz] ±3%rdg±3dgt[40Hz - 1kHz] 2000A(1500 - 2000A) ±3.0%rdg[50/60Hz]	400A(0 - 400A) ±1.5%rdg±3dgt[45 - 65Hz] ±2.5%rdg±3dgt[40Hz - 1kHz] 2000A(0 - 1500A) ±2%rdg±5dgt[45 - 65Hz] ±3%rdg±5dgt[40Hz - 1kHz] 2000A(1500 - 2000A) ±4%rdg[50/60Hz]
AC V	40/400/750V ±1%rdg±2dgt[50/60Hz] ±1.5%rdg±3dgt[40Hz - 1kHz]	40/400/750V ±1%rdg±2dgt[45 - 65Hz] ±1.5%rdg±3dgt[40Hz - 1kHz]
DC V	40/400/1000V ±1%rdg±2dgt	
Continuity buzzer	Buzzer sounds below 50±35Ω	
Ω	400Ω/4/40/400kΩ ±1.5%rdg±2dgt	
Conductor size	φ55mm max.	
Frequency response	40Hz - 1kHz	
Output	Recorder:DC400mV against AC400A DC200mV against AC2000A	
Applicable Standards	IEC 61010-1 CAT III 600V / CAT II 1000V IEC 61010-031, IEC 61010-2-032, IEC 61326-1	
Power source	R6(AA)(1.5V) × 2 *Continuous measuring time : Approx. 150 hours (2002PA) *Continuous measuring time : Approx. 80 hours (2002R) (Auto power save : Approx. 10 minutes)	
Dimension	247(L) × 105(W) × 49(D)mm	
Weight	Approx. 470g	
Accessories	7107A(Test leads), 9094(Carrying case) R6(AA) × 2, Instruction manual	
Optional Accessories	7256(Output cord)	

MODEL 2031



CE

Ø24 MAX 200A AC A DATA HOLD AUTO POWER OFF

- Can measure large AC current up to 200A
- 24mm tear drop shaped jaws
- Minimum resolution 0.01A

	2031
AC A	20A ±2%rdg±5dgt[50Hz - 1kHz] 200A ±2%rdg±5dgt[50/60Hz] ±3%rdg±10dgt[40Hz - 1kHz]
Conductor size	φ24mm max.
Frequency response	40Hz - 1kHz
Applicable Standards	IEC 61010-1 CAT III 300V
Power source	LR44(1.5V) × 2 *Continuous measuring time : Approx. 100 hours (Auto power off : Approx. 10 minutes)
Dimension	147(L) × 58.5(W) × 26(D)mm
Weight	Approx. 100g
Accessories	9090 (Carrying case) LR44 × 2 Instruction manual

DIGITAL AC CLAMP METERS

KEW 2117R

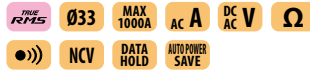

- Fully Safety jaw
- Ergonomic over-molded body gives convenient one-hand operation
- Large easy-to-read display with 0.01A resolution
- Accurate reading with True RMS 60/600/1000A auto-ranging
- Long battery life
- Safety Standard IEC 61010-1 CAT IV 300V / CAT III 600V



CE

	2117R
AC A	60.00/600.0/1000A (Auto-ranging) ±1.5%rdg±4dgt [45 - 65Hz] ±2.0%rdg±5dgt [40Hz - 1kHz]
AC V	60.00/600.0V (Auto-ranging) ±1.0%rdg±2dgt [45 - 65Hz] (600V) ±1.5%rdg±4dgt [40Hz - 1kHz] (60/600V)
DC V	60.00/600.0V (Auto-ranging) ±1.0%rdg±3dgt (60V) ±1.2%rdg±3dgt (600V)
Ω	600.0Ω/6.000/60.00/600.0kΩ (Auto-ranging) ±1.0%rdg±5dgt (600Ω) ±2.0%rdg±3dgt (6/60/600kΩ)
Continuity buzzer	600Ω (Buzzer sounds below 90Ω)
Conductor size	φ33mm max.
Applicable Standards	IEC 61010-1 CAT IV 300V / CAT III 600V Pollution degree 2 IEC 61010-031, IEC 61010-2-032, IEC 61010-2-033 IEC 61326-2-2(EMC), IEC 60529 IP40
Power source	R03/LR03(AAA)(1.5V)x2 *Continuous measuring time : Approx. 170 hours (When R03 is used)(NCV_LED.off)(Auto power save : Approx.10 minutes)
Dimension	204(L) × 81(W) × 36(D)mm
Weight	Approx. 220g (including batteries)
Accessories	7066A (Test leads), 9079 (Carrying case), R03(AAA) × 2 Instruction manual

KEW 2127R

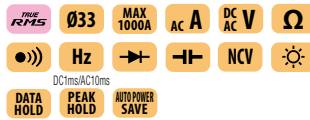

- Fully Safety jaw
- Ergonomic over-molded body gives convenient one-hand operation
- Large easy-to-read display with 0.01A resolution
- Accurate reading with True RMS 60/600/1000A auto-ranging
- Peak Hold for inrush current
- Large display with backlight
- Capacitance and Diode test
- Long battery life
- Safety standard IEC 61010-1 CAT IV 300V / CAT III 600V

CE

	2127R
AC A	60.00/600.0/1000A (Auto-ranging) ±1.5%rdg±4dgt [45 - 65Hz] ±2.0%rdg±5dgt [40Hz - 1kHz]
AC V	60.00/600.0V (Auto-ranging) ±1.0%rdg±2dgt [45 - 65Hz] (600V) ±1.5%rdg±4dgt [40Hz - 1kHz] (60/600V)
DC V	60.00/600.0V (Auto-ranging) ±1.0%rdg±3dgt (60V) ±1.2%rdg±3dgt (600V)
Ω	600.0Ω/6.000/60.00/600.0kΩ/6.000/40.00MΩ (Auto-ranging) ±1.0%rdg±5dgt (600Ω) ±2.0%rdg±3dgt (6/60/600kΩ) ±3.0%rdg±3dgt (6MΩ) ±5.0%rdg±3dgt (40MΩ)
Continuity buzzer	600Ω (Buzzer sounds below 90Ω)
Capacitance test	1.000/10.00/100.0μF ±3.0%rdg±15dgt (1μF) ±3.0%rdg±10dgt (10/100μF)
Hz	999.9Hz/9.999kHz (Auto-ranging) ±0.1%rdg±3dgt (Input sensitivity Current:more than 4A Voltage:more than 2V)
Conductor size	φ33mm max.
Applicable Standards	IEC 61010-1 CAT IV 300V / CAT III 600V Pollution degree 2 IEC 61010-031, IEC 61010-2-032, IEC 61010-2-033 IEC 61326-2-2(EMC), IEC 60529 IP40
Power source	R03/LR03(AAA)(1.5V) × 2 *Continuous measuring time : Approx. 170 hours (when R03 is used)(NCV_LED, Backlight:off)(Auto power save : Approx.10 minutes)
Dimension	204(L) × 81(W) × 36(D)mm
Weight	Approx. 230g (including batteries)
Accessories	7066A (Test leads), 9079 (Carrying case), R03(AAA) × 2 Instruction manual

KEW 2200/2200R



- Ultra Slim and lightweight Handy design
- φ33mm tear drop shaped jaws
- 1000A AC Clamp Meter
- DMM function ACV, DCV, Ω, Continuity buzzer
- Fuseless electronic protection on Ω/Ω up to 600V
- Safety standard IEC 61010-1 CAT IV 300V* / CAT III 600V IEC 61010-2-032 *2200R only
- Minimum resolution 0.01A

CE

	2200	2200R
Detection method	Averaging value	True RMS value
AC A	40.00/400.0/1000A (Auto-ranging) ±1.4%rdg±6dgt(50/60Hz) ±1.6%rdg±6dgt(45 - 65Hz)	40.00/400.0/1000A (Auto-ranging) ±1.5%rdg±5dgt(45 - 65Hz) ±2.0%rdg±5dgt(40Hz - 1kHz)
AC V	4.000/40.00/400.0/600V (Auto-ranging) ±1.8%rdg±7dgt(45 - 65Hz) ±2.3%rdg±8dgt(65 - 500Hz)	
DC V	400.0mV/4.000/40.00/400.0/600V (Auto-ranging) ±1.0%rdg±3dgt* *400mV range is excluded	
Ω	400.0Ω/4.000/40.00/400.0kΩ/4.000/40.00MΩ (Auto-ranging) ±2.0%rdg±4dgt(0 - 400kΩ) ±4.0%rdg±4dgt(4MΩ) ±8.0%rdg±4dgt(40MΩ)	
Continuity buzzer	Buzzer sounds below 50±30Ω	
Conductor size	φ33mm max.	
Applicable Standards	IEC 61010-1 CAT IV 300V* / CAT III 600V Pollution degree2(AC A) CAT III 300V / CAT II 600V Pollution degree2(AC/DC V) IEC 61010-031, IEC 61010-2-032, IEC 61326(EMC)	
Power source	R03/LR03(AAA)(1.5V) × 2	
Continuous measuring time	Approx. 350 hours	Approx. 120 hours
	Auto power off : Approx.10 minutes	
Dimension	190(L) × 68(W) × 20(D)mm	
Weight	Approx. 120g(including batteries)	
Accessories	7107A (Test leads), 9160 (Carrying case), R03(AAA) × 2, Instruction manual	

photo : 2200R

*1 2200R only

DIGITAL AC CLAMP METERS

KEW 2204R

TRUE RMS CAT IV 600V 070 MAX 400A AC A 
 DATA HOLD MAX/MIN AUTO POWER OFF



- Flexible and light weight clamp sensor
- True RMS
- MIN / MAX function
- Backlight LCD display
- IEC 61010-1 CAT IV 600V / CAT III 1000V
- Minimum resolution 0.001A

		2204R
AC A		
Range		4.000/40.00/400.0A
Accuracy		±3%rdg±5dgt(45-500Hz) (At the center of the circle formed by the flexible sensor)
Crest factor		Full scale CF<1.6, half scale<3.2 Effective input crest values are $\sqrt{2}$ times of the max values of each range.
Conductor size		φ70mm max.
Influence of Conductor position		Additional ±2%(max.) depending on the distance from the center position
Overload protection		500A AC for 10 seconds
Applicable Standards		IEC 61010-1, IEC 61010-2-032 CAT IV 600V / CAT III 1000V Pollution degree 2 IEC 61326-1(EMC), IEC 60529 IP40
Operating temperature and humidity range		0 - +50°C, relative humidity 80% or less(no condensation)
Storage temperature and humidity range		-10 - +60°C, relative humidity 70% or less(no condensation)
Power source		R03 / LR03(AAA)(1.5V) × 2 *Continuous measuring time : Approx. 120 hours (Auto power off : Approx.15 minutes)
Dimension		120(L) × 70(W) × 26(D) mm : Display unit 1.8m : Sensor cable
Weight		Approx. 200g (including batteries)
Accessories		9174 (Carrying case), LR03(AAA) × 2, Instruction manual

KEW 2210R

TRUE RMS CAT IV 600V 0150 MAX 3000A AC A 
 DATA HOLD MAX/MIN AUTO POWER OFF



- Flexible and light weight clamp sensor
- Wide reading range up to 3000A
- True RMS
- MIN / MAX function
- Backlight LCD display
- IEC 61010-1 CAT IV 600V / CAT III 1000V
- Minimum resolution 0.01A

		2210R
AC A		
Range		30.00/300.0/3000A
Accuracy		±3%rdg±5dgt [45 - 500Hz] (At the center of the circle formed by the flexible sensor)
Crest factor		Full scale CF<1.6, half scale<3.2 Effective input crest values are $\sqrt{2}$ times of the max values of each range.
Conductor size		φ150mm max.
Influence of Conductor position		Additional ±3% (max.) depending on the distance from the center position
Overload protection		5000A AC for 10 seconds
Applicable Standards		IEC 61010-1, IEC 61010-2-030 CAT IV 600V / CAT III 1000V Pollution degree 2 IEC 61010-2-032, IEC 61326-1(EMC), IEC 60529 IP40
Operating temperature and humidity range		0 - +50°C, relative humidity 80% or less(no condensation)
Storage temperature and humidity range		-10 - +60°C, relative humidity 70% or less(no condensation)
Power source		R03 / LR03 (AAA) (1.5V) × 2 *Continuous measuring time: Approx. 120hours (Auto power off: Approx. 15 minutes)
Dimension		120 (L) × 70 (W) × 26 (D) mm : Display unit 1.8m : Sensor cable
Weight		Approx. 300g (including batteries)
Accessories		9174 (Carrying case), LR03 (AAA) × 2, Instruction manual



Easy to use in crowded cable areas



Easy to clamp a wire in hard-to-reach narrow spaces

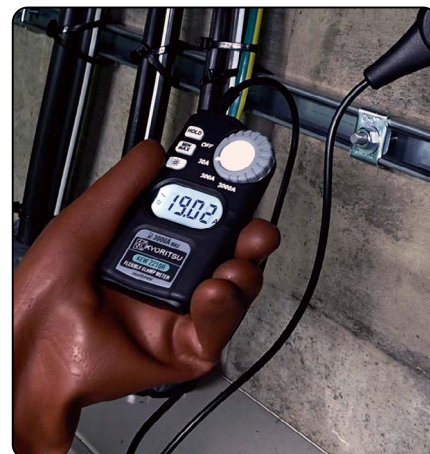

Easy to read backlight LCD display

DIGITAL AC/DC CLAMP METERS



CE

KEW 2003A

CAT IV 600V Ø55 MAX 2000A DC AC A DC AC V Ω
400ms

DATA HOLD PEAK HOLD OUT PUT AUTO POWER SAVE

- Measurement of both AC and DC current with transformer jaws of large diameter
- Can measure AC and DC currents up to 2000A
- Output terminal for recorder connection
- AC/DC voltage, resistance measurement and continuity functions also available
- Minimum resolution 0.1A

	2003A
AC A	400/2000A(0 - 1000A) ±1.5%rdg±2dgt[50/60Hz] ±3%rdg±4dgt[40 - 500Hz] ±5%rdg±4dgt[500Hz - 1kHz] 2000A(1001 - 1999A) ±3%rdg±2dgt[50/60Hz]
DC A	400/2000A ±1.5%rdg±2dgt
AC V	400/750V ±1.5%rdg±2dgt[50/60Hz] ±1.5%rdg±4dgt[40Hz - 1kHz]
DC V	400/1000V ±1%rdg±2dgt
Ω	400/4000Ω ±1.5%rdg±2dgt
Continuity buzzer	Buzzer sounds below 50±35Ω
Conductor size	φ55mm max.
Frequency response	40Hz - 1kHz
Output	Recorder: DC400mV against AC/DC400A DC200mV against AC/DC2000A
Applicable Standards	IEC 61010-1 CAT IV 600V / CAT III 1000V IEC 61010-2-032
Power source	R6(AA)(1.5V) × 2 *Continuous measuring time : Approx. 100 hours(Auto power save : Approx. 10 minutes)
Dimension	250(L) × 105(W) × 49(D)mm
Weight	Approx. 530g
Accessories	7107A(Test leads), 9094(Carrying case) R6(AA) × 2 Instruction manual
Optional Accessories	7256(Output cord)



CE

KEW 2009R

TRUE RMS CAT IV 600V Ø55 MAX 2000A DC AC A DC AC V
10rms

Ω Hz DATA HOLD PEAK HOLD OUT PUT

AUTO POWER OFF

- True RMS reading instrument ideal for accurate measurement of distorted waveforms and non-sinusoidal waveforms arising from thyristors
- Can measure AC and DC currents up to 2000A
- Output terminal for recorder connection
- Minimum resolution 0.1A

	2009R
AC A	400.0/2000A ±1.3%rdg±3dgt(0 - 400A,150 - 1700A)(45 - 66Hz) ±2.0%rdg±5dgt(0 - 400A,150 - 1700A)(20Hz - 1kHz) ±2.3%rdg±3dgt(1701 - 2000A)(45 - 66Hz)
DC A	400.0/2000A ±1.3%rdg±2dgt
AC V	40.00/400.0/750V ±1.0%rdg±3dgt(45 - 66Hz) ±1.5%rdg±5dgt(20Hz - 1kHz)
DC V	40.00/400.0/1000V ±1.0%rdg±2dgt
Ω	400.0/4000Ω ±1.5%rdg±2dgt
Continuity buzzer	Buzzer sounds below 20±1Ω
Hz	10 - 4000Hz ±1.5%rdg±5dgt (Input sensitivity Current:more than 40A Voltage:more than 10V)
Output	Recorder: DC400mV against AC/DC400A DC200mV against AC/DC2000A
Conductor size	φ55mm max.
Applicable Standards	IEC 61010-1 CAT IV 600V / CAT III 1000V IEC 61010-2-032, IEC 61326-2-2
Power source	R6 (1.5V) × 2 *Continuous measuring time: Approx. 11 hours (Auto power off: Approx. 10 minutes)
Dimension	250 (L) × 105 (W) × 49 (D) mm
Weight	Approx. 540g(including batteries)
Accessories	7107A(Test leads), 9094(Carrying case) R6(AA) × 2, Instruction manual
Optional Accessories	7256(Output cord)



MODEL 2010

Ø7.5 MAX 20A DC AC A OUT PUT

- High sensitivity, miniature AC/DC clamp meter
- 0.1mA minimum resolution for AC current and 1mA minimum resolution for DC current
- Output terminal for recorder connection

	2010
AC A	200mA/2/20A ±1%rdg±2dgt[50/60Hz](200mA) ±1.5%rdg±8dgt[40Hz - 2kHz](200mA) ±1%rdg±2dgt[50/60Hz](2A) ±2.5%rdg±10dgt[40Hz - 2kHz](2/20A)
DC A	2/20A ±1%rdg±2dgt(2A) ±1.5%rdg±4dgt(20A)
Conductor size	φ7.5mm max.
Frequency response	DC 40Hz - 2kHz
Output	Recorder: DC200mV against AC200mA/2/20A DC200mV against DC2/20A
Power source	6LR61(9V Alkaline battery) × 1 or AC adapter *Continuous measuring time : Approx. 20 hours (DC)/Approx. 40 hours (AC)
Dimension	142(L) × 64(W) × 26(D)mm : Display unit 153(L) × 23(W) × 18(D)mm : Sensor
Weight	Approx. 220g
Accessories	9095(Carrying Case), 6LR61 × 1, Instruction manual
Optional Accessories	7256(Output cord)

DIGITAL AC/DC CLAMP METERS



CE

MODEL 2033

Ø24 MAX 300A DC AC A DATA HOLD AUTO POWER SAVE

- Smallest clamp meter capable of AC and DC current measurements
- 300A auto-ranging has minimum resolution of 0.01A AC/DC
- Zero adjustment of DC current is possible at the push of a button

	2033
AC A	40/300A ±1%rdg±4dgt[50/60Hz](0 - 40A) ±2.5%rdg±4dgt[20Hz - 1kHz](0 - 40A) ±1.5%rdg±4dgt[50/60Hz](20 - 200A) ±2.5%rdg±4dgt[20Hz - 1kHz](20 - 200A) ±3.5%rdg[50/60Hz](200 - 300A) ±4%rdg[20Hz - 1kHz](200 - 300A)
DC A	40/300A ±1%rdg±4dgt(0 - ±40A) ±1.5%rdg±4dgt(±20 - ±200A) ±3%rdg(±200 - ±300A)
Conductor size	φ24mm max.
Frequency response	DC 20Hz - 1kHz
Applicable Standards	IEC 61010-1 CAT III 300V IEC 61010-2-032
Power source	LR44(1.5V) × 2 *Continuous measuring time : Approx. 10 hours (Auto power save : Approx. 5 minutes)
Dimension	147(L) × 59(W) × 25(D)mm
Weight	Approx. 100g
Accessories	9090 (Carrying case) LR44 × 2 Instruction manual



CE

KEW 2046R

RMS CAT IV 600V Ø33 MAX 600A DC AC V DC AC A
Ω Hz DUTY 10ms
°C NCV DATA HOLD PEAK HOLD MAX/MIN
REL AUTO POWER OFF

- Very useful for power distribution companies, power utilities and maintenance fields
- Red LED, as "Non Contact Voltage" function, gives warning to the user on the presence of AC voltage
- Double molding gives comfortable feeling in palm
- 6039 counts with Bar Graph display
- Minimum resolution 0.1A

	2046R
AC A	0 - 600.0A ±2.0%rdg±5dgt(50/60Hz) ±3.5%rdg±5dgt(40 - 500Hz)
DC A	0 - 600.0A ±1.5%rdg±5dgt
AC V	6/60/600V(Auto-ranging) ±1.5%rdg±4dgt(50/60Hz) ±3.5%rdg±5dgt(40 - 400Hz)
DC V	600mV/6/60/600V(Auto-ranging) ±1.0%rdg±3dgt
Ω	600Ω/6/60/600kΩ/6/60MΩ(Auto-ranging) ±1%rdg±5dgt(600 - 6M) / ±5%rdg±8dgt(60M)
Continuity buzzer	Buzzer Sounds at 100Ω
Hz	10/100Hz/1/10kHz(Auto-ranging) (Input sensitivity Current:more than 50A[40 - 400Hz] Voltage:more than 1V[6V Range], 4.2V[60V Range], 42V[600V Range][- 10kHz])
DUTY	0.1 - 99.9% ±2.5%rdg ±5dgt (Pulse width/Pulse cycle)
Capacitance test	400nF/4/40μF(Auto-ranging)
Temperature	-50°C - +300°C(with the use of Temperature probe 8216)
Conductor size	φ33
Applicable Standards	IEC 61010-1 CAT IV 600V IEC 61010-2-032, IEC 61326
Power source	R03 (1.5V)(AAA) × 2 *Continuous measuring time : Approx. 10 hours (Auto power off : Approx. 15 minutes)
Dimension	243(L) × 77(W) × 36(D) mm
Weight	Approx. 300g
Accessories	7066A(Test leads), 9094(Carrying case), R03 × 2, Instruction manual
Optional Accessories	8216(Temperature probe)



CE

KEW 2055/2056R

2056R RMS CAT IV 600V Ø40 MAX 1000A DC AC V DC AC A 2056R
Ω Hz DUTY 10ms
°C NCV DATA HOLD PEAK HOLD MAX/MIN
REL 2055 AUTO POWER SAVE 2056R AUTO POWER OFF

- Very useful for power distribution companies, power utilities and maintenance fields
- Red LED, as "Non Contact Voltage" function, gives warning to the user on the presence of AC voltage
- Double molding gives comfortable feeling in palm
- 6039 counts with Bar Graph display
- Minimum resolution 0.1A

photo : 2056R

	2055	2056R
AC A	0 - 600.0/1000A ±1.5%rdg±5dgt(50/60Hz) ±3.0%rdg±5dgt(40 - 400Hz)	0 - 600.0/1000A ±2.0%rdg±5dgt(50/60Hz) ±3.5%rdg±5dgt(40 - 500Hz)
DC A	0 - 600.0/1000A ±1.5%rdg±5dgt	
AC V	6/60/600V(Auto-ranging) ±1.3%rdg±4dgt(50/60Hz) ±3.0%rdg±5dgt(40 - 400Hz)	6/60/600V(Auto-ranging) ±1.5%rdg±4dgt(50/60Hz) ±3.5%rdg±5dgt(40 - 400Hz)
DC V	600mV/6/60/600V(Auto-ranging) ±1.0%rdg±3dgt	
Ω	600Ω/6/60/600kΩ/6/60MΩ (Auto-ranging) ±1%rdg±5dgt(600 - 6M) / ±5%rdg±8dgt(60M)	
Continuity buzzer	Buzzer Sounds at 100Ω	
Capacitance test	-	400nF/4/40μF(Auto-ranging)
Temperature	-	-50 - +300°C (with the use of Temperature probe 8216)
Hz	10/100Hz/1/10kHz(Auto-ranging) (Input sensitivity Current:more than 50A[40 - 400Hz] Voltage:more than 1V[6V Range], 4.2V[60V Range], 42V[600V Range][- 10kHz])	
DUTY	0.1 - 99.9% ±2.5%rdg ±5dgt (Pulse width/Pulse cycle)	
Conductor size	φ40	
Applicable Standards	IEC 61010-1 CAT IV 600V, IEC 61010-2-032, IEC 61326	
Power source	R03 (1.5V)(AAA) × 2 *Continuous measuring time : Approx. 35 hours (Auto power save : Approx. 15 minutes) (2055) *Continuous measuring time : Approx. 10 hours (Auto power off : Approx. 15 minutes) (2056R)	
Dimension	254(L) × 82(W) × 36(D) mm	
Weight	Approx. 310g	
Accessories	7066A(Test leads), 9094(Carrying case), R03 × 2, Instruction manual	
Optional Accessories	-	8216(Temperature probe)

DC MILLIAMP CLAMP METER/CLAMP LOGGER

KEW 2500/2510

2510 2510
 Ø6 DC A DATA HOLD AUTO POWER OFF OUT PUT Bluetooth External Power Supply



photo : 2510



- 0.01mA resolution for DC current
- Top class measurement with 0.2% accuracy
- Ø6mm clamp jaw easy to use in tight places
- Measurement from 0.01 to 120.0mA
- Dual display with backlight shows both measured value (mA) and percentage value of 4-20 mA span
- Spotlight for illuminating measurement point
- Analog output terminal for recorder connection
- Memory function stores up to 192,000 records (2510 only)
- Transfer data to PC via Bluetooth (2510 only)

	2500	2510
DC A	20/100mA(Auto-ranging) ±0.2%rdg±5dgt(0.00 - 21.49mA) ±1.0%rdg±5dgt(21.0 - 120.0mA)	
Conductor size	φ6mm max.	
Analog output	Recorder: DC1000mV against DC100mA	
Communication Interface	—	Bluetooth® 5.0*
Applicable Standards	IEC 61010-1 Pollution degree 2 IEC 61010-2-032, IEC 61326-1(EMC) IEC 60529 IP40	
Operating temperature and humidity range	-10 - +50°C, relative humidity 85% or less (no condensation)	
Storage temperature and humidity range	-20 - +60°C, relative humidity 85% or less (no condensation)	
Power source	R6/LR6(AA) (1.5V) × 4	R6/LR6(AA) (1.5V) × 4 (Alkaline LR6 is recommended.) External supply (AC adapter MODEL 8320)
Battery life	Approx. 60 hours continuous (with Backlight and LED light OFF)	Approx. 50 hours continuous with alkaline batteries (with Backlight, LED light and Bluetooth® feature OFF)
Dimension	111(L) × 61(W) × 40(D)mm : Display unit 104(L) × 34(W) × 20(D)mm : Sensor 700mm : Sensor cable	111(L) × 61(W) × 46(D)mm : Display unit 104(L) × 34(W) × 20(D)mm : Sensor 700mm : Sensor cable
Weight	Approx. 290g (including batteries)	Approx. 310g (including batteries)
Accessories	9096(Carrying case) LR6(AA) × 4 Instruction manual	8320(AC adapter) KEW Windows for 2510(Software) 9096(Carrying case) LR6(AA) × 4, Instruction manual Software installation manual
Optional Accessories	7256(Output cord)	

*Some countries regulate the compliance with their Radio Law of the products equipped with Bluetooth®. Please confirm it with your distributor before purchasing our products equipped with Bluetooth®.

Analog output terminal for recorder connection

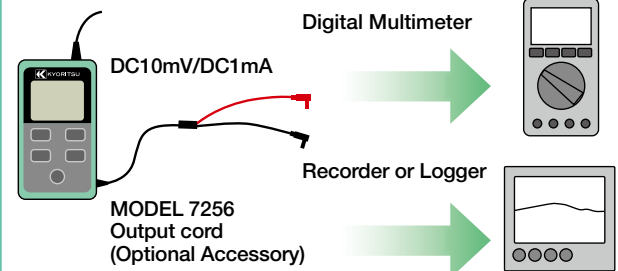

Note: The Auto power off can be disabled for long recording

Memory function/Communication function (2510 only)

Measured data can be transferred to a PC

Five selectable recording intervals

Memory capacity up to 192,000 data

Analyzing and processing the measured data with a PC

Recording interval	Max recording period
1 sec.	53 hours
5 sec.	11 days
10 sec.	22 days
30 sec.	66 days
60 sec.	133 days

External supply

Bluetooth®

System requirements

OS : Windows® 11/10
 Display : XGA(Resolution 1024 × 768 dots) or more
 Required HDD space: 1Gbyte or more
 Others : With CD-ROM drive, .NET Framework (4.6.1 or later)

* Windows® is registered trademark of Microsoft in the United States.
 * Bluetooth® is a registered trademark of Bluetooth SIG.

Accessories

MODEL 9096
Carrying case



— 2510 only —
MODEL 8320
AC adapter



Optional Accessory

MODEL 7256
Output cord



KEW Windows for 2510



Diameter of measurable conductor : Ø6mm max



For signal measurement in process and building instrumentation



Spotlight LED & Backlight Display



LEAKAGE CLAMP METERS



CE

MODEL 2431

Ø24 MAX 200A Resolution 0.01mA AC A DATA HOLD Filter

AUTO POWER OFF

- Frequency Selector Switch to eliminate the effect of harmonics
- Auto power-off function
- Rotary switch for easy one finger power-on and range selection
- Minimum resolution 0.01mA

	2431
AC A (50/60Hz)	20/200mA/200A ±3%rdg±5dgt(20/200mA/100A) ±5%rdg±5dgt(200A)
AC A (WIDE)	20/200mA/200A ±2%rdg±4dgt[50/60Hz](20/200mA/0 - 100A) ±5%rdg±6dgt[40 - 400Hz](20/200mA/0 - 100A) ±5%rdg±4dgt[50/60Hz](100.1 - 200A)
Conductor size	φ24mm max.
Frequency response	40 - 400Hz
Effect of external stray magnetic field φ15mm 100A	10mA AC max.
Applicable Standards	IEC 61010-1 CAT III 300V, IEC 61010-2-032
Power source	LR44(1.5V) × 2 *Continuous measuring time : Approx. 15 hours (Auto power off : Approx. 10 minutes)
Dimension	149(L) × 60(W) × 26(D)mm
Weight	Approx. 120g
Accessories	9090 (Carrying case) LR44 × 2 Instruction manual



CE

MODEL 2432

High Sensitive Model

Ø40 MAX 100A Resolution 0.001mA AC A DATA HOLD PEAK HOLD 10ms

Filter AUTO POWER OFF

- Frequency Selector Switch to eliminate the effect of harmonics
- Three ranges: 4/40mA/100A
- Minimum resolution 0.001mA

	2432
AC A (50/60Hz)	4/40mA/100A ±1%rdg±5dgt(4/40mA) ±1%rdg±5dgt(0 - 80A) ±5%rdg(80.1 - 100A)
AC A (WIDE)	4/40mA/100A ±1%rdg±5dgt[50/60Hz] ±2.5%rdg±10dgt[20Hz - 1kHz](4/40mA) ±1%rdg±5dgt[50/60Hz] ±2.5%rdg±10dgt[40Hz - 1kHz](0 - 80A) ±5%rdg[50/60Hz] ±10%rdg[40Hz - 1kHz](80.1 - 100A)
Maximum circuit voltage	600V AC/DC (between line/neutral) 300V AC/DC (against earth)
Conductor size	φ40mm max.
Frequency response	20Hz - 1kHz(40Hz - 1kHz:100A)
Effect of external stray magnetic field	Approx. 2mA AC in proximity to a 15mm conductor carrying 100A AC
Applicable Standards	IEC 61010-1 CAT III 300V Pollution degree 2 IEC 61010-2-032
Power source	R03(DC1.5V) × 2 *Continuous measuring time : Approx. 40 hours (Auto power off : Approx. 10 minutes)
Dimension	185(L) × 81(W) × 32(D)mm
Weight	Approx. 290g
Accessories	9097(Carrying case), R03 × 2, Instruction manual



CE

MODEL 2433/2433R

2433R TRUE RMS Ø40 MAX 400A Resolution 0.01mA AC A DATA HOLD

10ms PEAK HOLD Filter AUTO POWER OFF

- Frequency Selector Switch to eliminate the effect of harmonics
- Three ranges: 40/400mA/400A
- Minimum resolution 0.01mA

	2433	2433R
AC A (50/60Hz)	40.00/400.0mA/400.0A ±1%rdg±5dgt(40/400mA) ±1%rdg±5dgt(0 - 350A) ±2%rdg(350.1 - 399.9A)	40.00/400.0mA/400.0A ±1%rdg±5dgt(0 - 100A) ±1%rdg±5dgt(100 - 300A) ±2%rdg(300 - 400A)
AC A (WIDE)	40.00/400.0mA/400.0A ±2.5%rdg±10dgt[20Hz - 1kHz](40/400mA) ±2.5%rdg±10dgt[40Hz - 1kHz](0 - 350A) ±5%rdg[40Hz - 1kHz](350.1 - 399.9A)	40.00/400.0mA/400.0A ±2.5%rdg±10dgt[20Hz - 1kHz](0/100A) ±2.5%rdg±10dgt[40Hz - 1kHz](100 - 300A) ±5%rdg[40Hz - 1kHz](300 - 400A)
Maximum circuit voltage	600V AC/DC (between line/neutral)	300V AC/DC (against earth)
Conductor size	φ40mm max.	
Frequency response	20Hz - 1kHz(40Hz - 1kHz:400A)	
Effect of external stray magnetic field	Approx. 10mA AC in proximity to a 15mm conductor carrying 100A AC	
Applicable Standards	IEC 61010-1 CAT III 300V Pollution degree 2, IEC 61010-2-032	
Power source	R03 (DC1.5V) × 2 *Continuous measuring time : Approx. 40 hours (2433) *Continuous measuring time : Approx. 24 hours (2433R) (Auto power off : Approx 10 minutes)	
Dimension	185(L) × 81(W) × 40(D)mm	
Weight	Approx. 270g	
Accessories	9097 (Carrying case), R03 × 2, Instruction manual	

photo : 2433R

LEAKAGE CLAMP METERS/FORK CURRENT TESTER

KEW 2413F/2413R



CE

2413R
 True RMS **Ø68** MAX 1000A AC A DATA HOLD PEAK HOLD
 Resolution 0.1mA OUTPUT Filter

- Large transformer jaws of 68mm diameter makes it possible to clamp on all three or four wires (3 phases) together for leakage current measurement
- Frequency filter switch to eliminate the effect of the harmonics
- 2 way analog output terminal
- Minimum resolution 0.1mA

photo : 2413R

	2413F	2413R
AC A (50/60Hz)	200mA/2/20/200/1000A ±1.5%rdg±2dgt(200mA/2/20A) ±2.0%rdg±2dgt(200A/0 - 500A) ±5.5%rdg(501 - 1000A)	200mA/2/20/200/1000A ±2.5%rdg±5dgt(200mA/2/20A) ±3.0%rdg±5dgt(200A/0 - 500A) ±5.5%rdg(501 - 1000A)
AC A (WIDE)	200mA/2/20/200/1000A ±1.0%rdg±2dgt(50/60Hz) ±3.0%rdg±2dgt(40Hz - 1kHz)(200mA/2/20A) ±1.5%rdg±2dgt(50/60Hz) ±3.5%rdg±2dgt(40Hz - 1kHz)(200A/0 - 500A) ±5%rdg(50/60Hz) ±10%rdg(40Hz - 1kHz)(501 - 1000A)	200mA/2/20/200/1000A ±1.8%rdg±5dgt(50/60Hz) ±3.0%rdg±5dgt(40Hz - 1kHz)(200mA/2/20A) ±2.0%rdg±5dgt(50/60Hz) ±3.5%rdg±5dgt(40Hz - 1kHz)(200A/0 - 500A) ±5.0%rdg(50/60Hz)(501 - 1000A)
Conductor size	φ68mm max.	
Frequency response	40Hz - 1kHz	
Effect of external stray magnetic field φ15mm 100A	10mA AC max.	
Output	Waveform:AC200mV against the maximum value of each range (1000A range is 100mV) Recorder:DC200mV against the maximum value of each range (1000A range is 100mV)	
Crest factor	— 3.0 or less	
Applicable Standards	IEC 61010-1 CAT III 300V, IEC 61010-2-032	
Power source	6F22(9V) × 1 *Continuous measuring time : Approx. 60 hours	
Dimension	250(L) × 130(W) × 50(D)mm	
Weight	Approx. 570g	Approx. 600g
Accessories	9094(Carrying case), 6F22 × 1, Instruction manual	
Optional Accessories	7073(2WAY Output cord)	

MODEL 2434



CE

Ø28 MAX 100A Resolution 0.1mA AC A DATA HOLD Filter
 AUTO POWER SAVE

- Least affected by external stray magnetic field
- Frequency Selector Switch to eliminate the effect of harmonics
- Minimum resolution 0.1mA

	2434
AC A (50/60Hz)	400mA/4/100A ±2%rdg±4dgt
AC A (WIDE)	400mA/4/100A ±2%rdg±4dgt(50/60Hz) ±3%rdg±5dgt(40 - 400Hz)
Conductor size	φ28mm max.
Frequency response	40 - 400Hz
Effect of external stray magnetic field φ15mm 100A	20mA AC max.
Applicable Standards	IEC 61010-1 CAT III 300V, IEC 61010-2-032
Power source	R03(AAA) (1.5V) × 2 *Continuous measuring time : Approx. 150 hours(Auto power save : Approx. 10 minutes)
Dimension	169(L) × 75(W) × 40(D)mm
Weight	Approx. 220g
Accessories	9097(Carrying case), R03 × 2, Instruction manual

KEW 2300R



CE

KEW FORK CURRENT TESTER

True RMS **Ø10** MAX 100A DC AC A NCV DATA HOLD
 AUTO POWER OFF

- True RMS reading is an essential feature for accurate measurement
- "Non Contact Voltage" function indicates the presence of AC voltage by warning the user with an audible signal
- Zero adjustment of DC current is possible at the push of a button
- Auto Power Off
- Minimum resolution 0.1A

	2300R
Current measurement	AC A 0 - 100.0A ±2.0%rdg±5dgt [50/60Hz] DC A 0 - ±100.0A ±2.0%rdg±5dgt
Crest factor	2.5
Non contact voltage	Detect AC voltage without contacting with socket wire. During voltage detection, "Hi" flashes and a buzzer sounds.
Maximum digit	1,049
Conductor size	Max φ10mm
Applicable Standards	IEC 61010-1 CAT III 300V Pollution degree 2
Power source	R03 (AAA) × 2 (Auto power off : Approx. 10 minutes) *Continuous measuring time : AC A Approx. 46 hours DC A Approx. 52 hours
Dimension	161(L) × 40(W) × 30(D)mm
Weight	110g (including batteries)
Accessories	9113(Carrying case), R03 (AAA) × 2, Instruction manual



KEW 2300R can be used in crowded connection boxes, where cables are very short, and space is too limited to clamp cables using a traditional clamp meter.

LEAKAGE CLAMP METERS

ADVANTAGES USING THE KYORITSU LEAKAGE CLAMP METERS:

- Work professionally: No need random check to identify the fault that causes RCD tripping. In fact our leakage clamp meters measure exactly the same leakage current to earth / ground detected by RCD. Once you measured it, you trace and find it. It is like to have an RCD "built-in" your clamp meter, nothing will trip on it but you will measure the leakage current on its display!
- Easy to use, you just need to clamp:
 - all active conductors (for leakage current measurements)
 - or just one phase (for the AC load current measurements, like the conventional clamp meters ranging up to 100A / 200A / 400A or 1000A, depends on the model).
- Before starting any action, clamping the active conductors at the origin of the electrical installation: you will immediately know if there is a leakage current to earth / ground.
- Then you will trace the leakage current clamping every secondary circuit one by one and without disconnecting the conductors in the junction boxes (see the below example).
- No wasting time because using these special clamp meters you will find out the fault without turning OFF the power line.
- When there are more than one fault, that only the sum of them causes the RCD tripping, such clamp meters are even more useful for a definitive solution.
- An essential tool to identify the causes of leakage current to earth / ground, you will appreciate it since the first use!

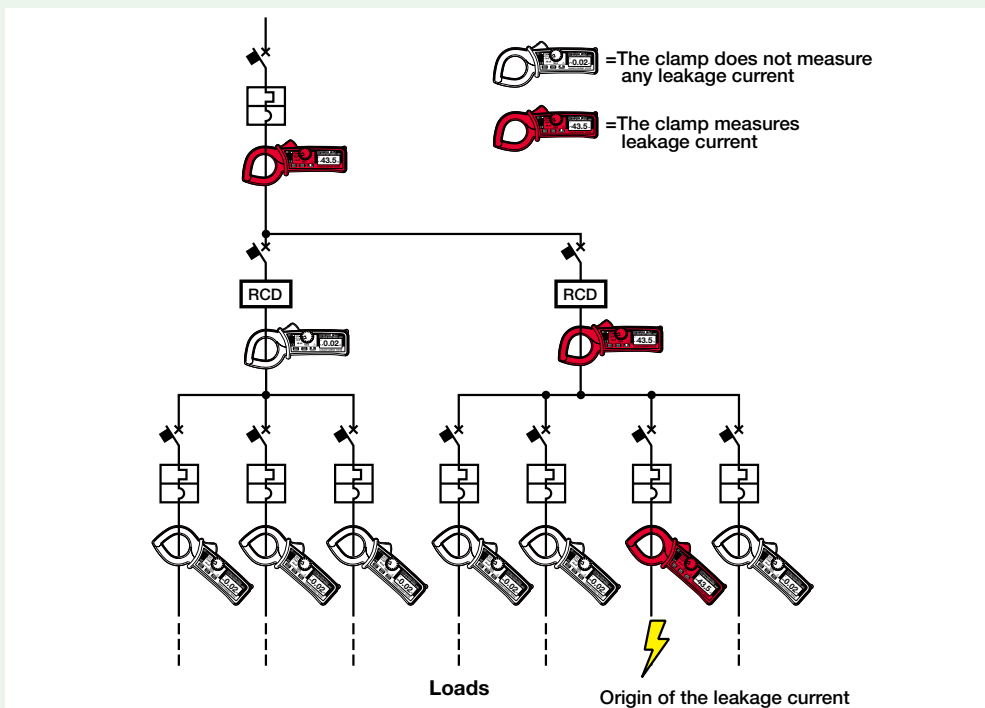

High frequency selector switch

All the leakage clamp meters of Kyoritsu have a frequency response selector switch that allows you to determine the level of earth / ground leakage current including or not the high frequency.

In other words, it can help to identify the "traditional" leakage current at 50/60 Hz (generated by low insulation condition of motors, of old lightings, of cables, etc) and the "high frequency" leakage current (generated by PC, inverters, UPS, harmonics, etc).

Therefore this feature is very helpful for a quick judgment: the leakage is due to poor insulation resistance or due to problems with devices that work with high frequency.

Discover here more details on the use of the Kyoritsu Leakage clamp meters: <https://www.kew-ltd.co.jp/en/support/applicationnotes.html>



CLAMP SENSOR/CLAMP ADAPTER

KEW 8115

CLAMP SENSOR



CE

- Clamp sensor for AC/DC current measurement compatible with digital multimeters

	8115	
Measuring range	AC 0.1 - 130Arms	DC 0 - ±180A
Output voltage	AC 10mV/A	DC 10mV/A
Accuracy	±1.2%rdg±0.4mV (50/60Hz) ±2.5%rdg±0.4mV (40Hz - 1kHz)	±1.2%rdg±0.4mV (*)
Low battery warning	2.2V±0.2V or less - Red LED flash (1.9V±0.2V - Automatically power off)	
Conductor size	φ12mm max.	
Operating temperature & humidity range	-10 - 55°C, relative humidity 85% or less (no condensation)	
Output impedance	Approx. 10Ω or less	
Applicable Standards	IEC 61010-1 CAT III 300V Pollution degree 2, IEC 61010-2-032, IEC 61326-1	
Power source	LR03(AAA)(1.5V) × 2 Continuous use: Approx. 40 hours(Auto power off: Approx. 20 minutes)	
Cord length	Approx. 1,200mm	
Output connector	φ4mm banana plug	
Dimension	127(L) × 42(W) × 22(D) mm	
Weight	Approx. 140g	
Accessories	9095(Carrying case), LR03(AAA) × 2, Instruction manual	

*This accuracy is defined after the completion of zero adjustment under connection to a DMM.

MODEL 8112

CLAMP ADAPTER



CE

- MODEL 8112 clamp adapter is designed as an AC current/voltage conversion probe capable of measuring AC current from 0.1mA to 120A in conjunction with digital multimeters

		8112		
Range	Measuring ranges	Output voltage	Accuracy	Frequency response
200mA	AC 0 - 500mA	AC1V/A	±1.5%rdg±0.2mA	50Hz - 1kHz
	AC 0 - 1000mA	(1000mA→1V)	±3%rdg±0.4mA	40Hz - 10kHz
2A	AC 0 - 20A	AC100mV/A (20A→2V)	±1%rdg±1mA ±1.5%rdg±2mA	40Hz - 1kHz 1 - 10kHz
	AC 0 - 20A	AC10mV/A (120A→1.2V)	±1%rdg±0.01A ±2.5%rdg ±2.5%rdg	40Hz - 1kHz 50Hz - 10kHz 100Hz - 10kHz
Conductor size		φ8mm max.		
Frequency characteristics		30Hz - 100kHz(-3dB)		
Applicable Standard		IEC 61010-1 CAT II 100V Pollution degree 2		
Dimension		153(L) × 18(W) × 23(D)mm		
Weight		Approx. 100g		
Accessories		9095(Carrying case) Instruction manual		

KEW 8161

CLAMP SENSOR



CE

- Clamp sensor for AC current measurement compatible with digital multimeters

	8161
Measuring range	AC0 - 100A
Output voltage	AC 1000mV/AC 100A(10mV/A)
Accuracy	±2.0%rdg±3.0mV (45 - 65Hz) ±2.5%rdg±3.0mV (65Hz - 1kHz)
Conductor size	φ24mm max.
Operating temperature & humidity range	-10 - 50°C, relative humidity 85% or less(no condensation)
Output impedance	22Ω or less
Applicable Standards	IEC 61010-1 CAT III 300V Pollution degree 2 IEC 61010-2-032, IEC 61326-1,2-2
Withstand voltage	AC3470Vrms (50/60Hz)for 5 sec.
Insulation resistance	50MΩ or greater at 1000V
Output connector	22Ω or less
Dimension	97(L) × 59(W) × 26(D)mm
Cable length	Approx. 1.2m
Weight	Approx. 120g
Accessories	Instruction manual

INSULATION TESTERS





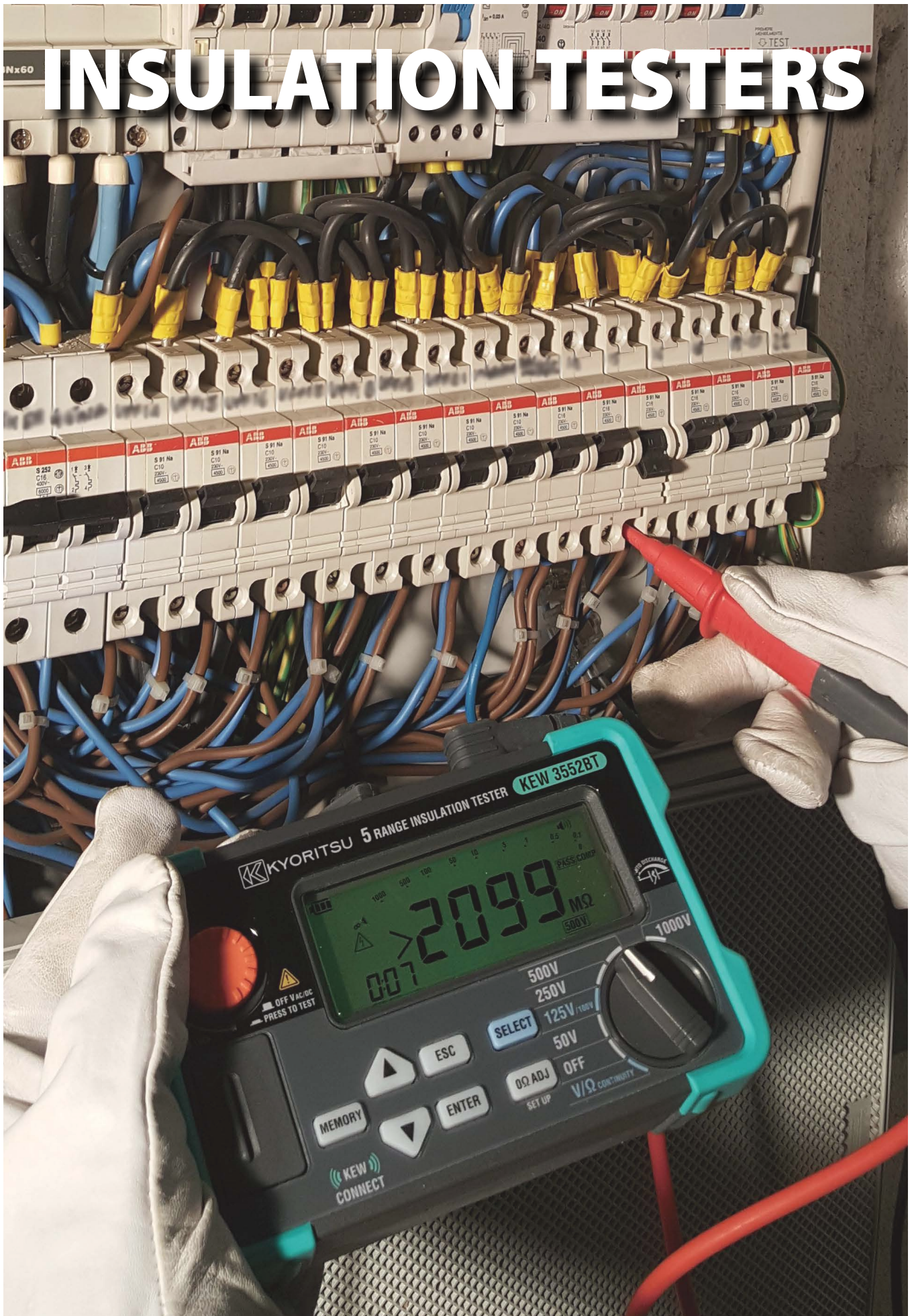



INSULATION TESTERS











INSULATION TESTERS











INSULATION TESTERS

Selection Guide of Insulation Testers

	Analog Insulation Testers				Analog Insulation/Continuity Testers	
	3165	3166	3161A	3431	3131A	3132A
Appearance	 photo : 3165					
Test voltage	1 range		2 ranges		3 ranges	
Rated voltage (Max. measurement value)	500V(1000MΩ)	1000V(2000MΩ)	15V(20MΩ) 500V(100MΩ)	250V(200MΩ) 500V(200MΩ) 1000V(2000MΩ)	250V(100MΩ) 500V(200MΩ) 1000V(400MΩ)	250V(100MΩ) 500V(200MΩ) 1000V(400MΩ)
Continuity 	-	-	-	-	2/20Ω	3/500Ω
AC Voltage 	600V	600V	600V	600V	-	600V
DC Voltage 	-	-	-	600V	-	-
Backlight 	-	-	✓	✓	✓	-
Power source	R6 × 4	R6 × 4	R6 × 4	LR6 × 4	R6 × 6	R6 × 6
Dimension (L) × (W) × (D)mm	90 × 137 × 40	90 × 137 × 40	90 × 137 × 40	97 × 156 × 46	167 × 185 × 89	106 × 160 × 72
Weight(Approx.)	330g	330g	340g	430g	860g	560g

	Digital Insulation/Continuity Testers				
	3005A	3007A	3551	3552	3552BT
Appearance					
Test voltage	3 ranges			6 ranges	
Rated voltage (Max. measurement value)	250V(2000MΩ) 500V(2000MΩ) 1000V(2000MΩ)	250V(2000MΩ) 500V(2000MΩ) 1000V(2000MΩ)	50V(100MΩ) 100V(200MΩ) 125V(250MΩ) 250V(500MΩ) 500V(2000MΩ) 1000V(4000MΩ)	50V(100MΩ) 100V(200MΩ) 125V(250MΩ) 250V(500MΩ) 500V(20GΩ) 1000V(40GΩ)	50V(100MΩ) 100V(200MΩ) 125V(250MΩ) 250V(500MΩ) 500V(20GΩ) 1000V(40GΩ)
Continuity 	20/200/2000Ω	20/200/2000Ω	40/400/4000Ω	40/400/4000Ω	40/400/4000Ω
Continuity buzzer 	✓	✓	✓	✓	✓
AC Voltage 	600V	600V	2.0 - 600V	2.0 - 600V	2.0 - 600V
DC Voltage 	-	-	-2.0 - -600V 2.0 - 600V	-2.0 - -600V 2.0 - 600V	-2.0 - -600V 2.0 - 600V
Backlight 	-	✓	✓	✓	✓
Communication Interface	-	-	-	USB	USB, Bluetooth®
Power source	R6 × 8	R6 × 8	LR6 × 4	LR6 × 4	LR6 × 4
Dimension (L) × (W) × (D)mm	167 × 185 × 89	167 × 185 × 89	97 × 156 × 46	97 × 156 × 46	97 × 156 × 46
Weight(Approx.)	970g	990g	490g	490g	490g

	Analog High Voltage Insulation Testers			Digital High Voltage Insulation Testers		
	3121B/3122B	3123A	3124A	3025B/3125B	3127	3128
Appearance	 photo : 3121B			 photo : 3125B		
Test voltage	1 range	2 ranges	Variable	3025B: 4 ranges 3125B: 5 ranges	5 ranges	6 ranges(Variable)
Rated voltage (Max. measurement value)	3121B: 2500V(100GΩ) 3122B: 5000V(200GΩ)	5000V(200GΩ) 10000V(400GΩ)	1000V(100MΩ) 1 - 10kV(100GΩ)	250V(100MΩ) 500V(1000MΩ) 1000V(2GΩ) 2500V(100GΩ) 5000V(1000GΩ)*	250V(9.99GΩ) 500V(99.9GΩ) 1000V(199GΩ) 2500V(999GΩ) 5000V(9.99TΩ)	500V(500GΩ) 1000V(1TΩ) 2500V(2.5TΩ) 5000V(5TΩ) 10000V(35TΩ) 12000V(35TΩ)
AC/DC Voltage 	-	-	-	30 - 600V AC/DC	30 - 600V AC/DC	30 - 600V AC/DC
Current	-	-	-	-	0.00nA - 5.50mA	5.00nA - 2.40mA
Capacitance	-	-	-	-	5.0nF - 50.0μF*	5.0nF - 50.0μF*
Backlight 	-	-	-	✓	✓	✓
Communication Interface	-	-	-	-	USB, Bluetooth®	USB
Power source	LR14 × 8	R6 × 8	Ni-MH rechargeable battery(1.2V) × 8	LR14 × 8	Rechargeable lead storage battery (12V)	Rechargeable lead storage battery (12V)
Dimension (L) × (W) × (D)mm	177 × 226 × 100	200 × 140 × 80	200 × 140 × 80	177 × 226 × 100	380 × 430 × 154 (Instrument and Hard case)	330 × 410 × 180 (Instrument and Hard case)
Weight(Approx.)	3121B: 1600g 3122B: 1700g	1000g	1600g	3025B: 1700g 3125B: 1900g	8000g	9000g

*3 125B only

*At 5000V range 5.0nF - 25.0μF

*At 10000/12000V range 5.0nF - 1.0μF

DIGITAL INSULATION/CONTINUITY TESTERS

MODEL 3005A



- Bar graph to display insulation resistance
- Displays the value of external AC voltage with flashing symbol
- Auto null function to automatically subtract the test lead resistance before displaying the real continuity resistance value
- Live circuit warning buzzer
- Releasing the test button automatically discharges the charges stored in the circuit under test
- 200mA measuring current on continuity testing

	3005A
Insulation resistance	
Test voltage	250/500/1000V
Measuring ranges	20/200/2000MΩ
Output voltage on open circuit	Rated test voltage +20%, -0%
Nominal current	1mA DC min.
Output short circuit current	Approx. 1.5 mA DC
Accuracy	±1.5%rdg±5dgt(20/200MΩ) ±10%rdg±3dgt(2000MΩ)
Continuity test	
Measuring ranges	20/200/2000Ω
Output voltage on open circuit	7 - 12V DC
Measuring current	200mA DC min.
Accuracy	±1.5%rdg±5dgt(20Ω) ±1.5%rdg±3dgt(200/2000Ω)
AC voltage	
AC voltage range	0 - 600V AC
Accuracy	±5%rdg±3dgt
General	
Applicable Standards	IEC 61010-1 CAT III 300V Pollution degree 2 IEC 61010-2-034, IEC 61557-1,2,4 IEC 60529(IP54), IEC 61326-1(EMC)
Power source	R6(AA)(1.5V) × 8
Dimension	167(L) × 185(W) × 89(D)mm
Weight	Approx. 970g
Accessories	7122B(Test leads), 9074(Cord case) 8923(Fuse[0.5A/600V]) × 1 (included), 1 (spare) R6(AA) × 8, 9121(Shoulder strap) Instruction manual

Selection Guide

	3005A	3007A
200mA continuity range	✓	✓
Live circuit warning	✓	✓
Backlight		✓
Automatic discharge	✓	✓
Trac-Lok for extended battery life		✓

Accessory

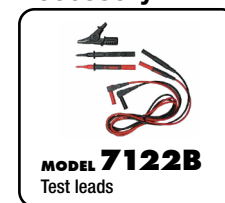

MODEL 3007A

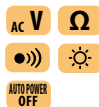

- Bar graph to display insulation resistance
- Displays the value of external AC voltage with flashing symbol
- Auto null function to automatically subtract the test lead resistance before displaying the real continuity resistance value
- Trac-Lok mode to conserve battery life on insulation and continuity tests
- Live circuit warning buzzer
- Releasing the test button automatically discharges the charges stored in the circuit under test
- Backlight function to view the test results in dimly lit areas
- 200mA measuring current on continuity testing

	3005A/3007A
Insulation resistance	
Test voltage	250/500/1000V
Measuring ranges	20/200/2000MΩ
Output voltage on open circuit	Rated test voltage +20%, -0%
Nominal current	1mA DC min.
Output short circuit current	1.5 mA DC approx.
Accuracy	±1.5%rdg±5dgt(20/200MΩ) ±10%rdg±3dgt(2000MΩ)
Continuity test	
Measuring ranges	20/200/2000Ω
Output voltage on open circuit	7 - 12V DC
Measuring current	200mA DC min.
Accuracy	±1.5%rdg±5dgt(20Ω) ±1.5%rdg±3dgt(200/2000Ω)
AC voltage	
AC voltage range	0 - 600V AC
Accuracy	±5%rdg±3dgt
General	
Applicable Standards	IEC 61010-1 CAT III 300V Pollution degree 2 IEC 61010-2-034, IEC 61557-1,2,4 IEC 60529(IP54), IEC 61326-1(EMC)
Power source	R6(AA)(1.5V) × 8
Dimension	167(L) × 185(W) × 89(D)mm
Weight	Approx. 990g
Accessories	7122B(Test leads), 9074(Cord case) 8923(Fuse[0.5A/600V]) × 1 (included), 1 (spare) R6(AA) × 8, 9121(Shoulder strap) Instruction manual

Accessories

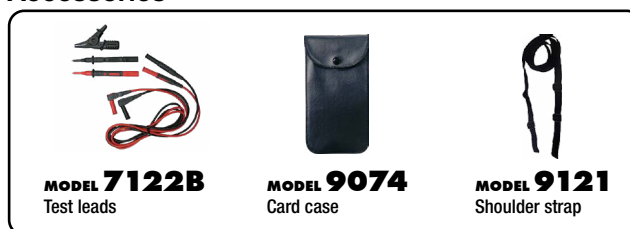

DIGITAL INSULATION/CONTINUITY TESTERS

KEW 3551/3552/3552BT

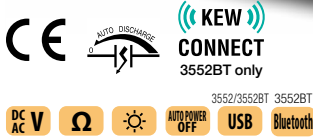

photo : 3552BT

- World's fastest class measurement speed (0.5 sec.)
- 6 ranges are available for insulation resistance test (50/100/125/250/500/1000V)
- Various lineup definitely fulfills your needs

KEW CONNECT

Using our Application the measurements can be taken and automatically saved, reducing the necessity to take notes in the field. (3552BT only)



3551/3552/3552BT						
Insulation resistance						
Test voltage	50V	100V	125V	250V	500V	1000V
Measuring range (Auto-ranging)	4.000/40.00/100.0MΩ	4.000/40.00/200.0MΩ	4.000/40.00/250.0MΩ	4.000/40.00/400.0/500.0MΩ	4.000/40.00/400.0/2000MΩ /20GΩ*1	4.000/40.00/400.0/4000MΩ /40GΩ*1
Mid-scale value	2MΩ	5MΩ		10MΩ	100MΩ	200MΩ
First effective measuring range	0.100-10.00MΩ	0.100-20.00MΩ	0.100-25.00MΩ	0.100-50.0MΩ	0.100-500MΩ	0.100-1000MΩ
Accuracy	±2%rdg±2dgt					
Second effective measuring range	0.050-0.099MΩ	10.01-100.0MΩ	20.01-200.0MΩ	50.1-500MΩ	501-2000MΩ	1001-4000MΩ
Accuracy	±5%rdg					
Rated current	1.0-1.1mA					
Output short circuit current	@0.05MΩ	@0.1MΩ	@0.125MΩ	@0.25MΩ	@0.5MΩ	@1MΩ
Ω/Continuity*3						
Resistance range	40.00/400.0/4000Ω (Auto-ranging)					
Accuracy	±2.5%rdg±8dgt					
Open-circuit voltage	5V(4-6.9V)					
Measuring current	200mA or more					
Voltage						
Range	AC 2.0-600V(45-65Hz)DC -2.0--600V +2.0--+600V					
Accuracy	±1%rdg±4dgt					
General						
Applicable Standards	IEC 61010 CAT III 600V / CAT IV 300V, IEC 61010-2-034 IEC 61557-1,2,4, IEC 61326-1,2-2,IEC 60529(IP40)					
Communication Interface	USB*1, Bluetooth® 5.0*2					
Dimension/Weight	97(L)x156(W)x46(D)mm / Approx. 490g (including battery)					
Power source	LR6/R6(AA)(1.5V) x 4					
Accessories	7260(Test lead with remote control switch), 7261A(Test lead with alligator clip) 8017A(Extension prod long), 9173(Carrying case), 9121(Shoulder strap), LR6(AA)x4, Instruction manual					
Optional Accessories	9186A(Carrying case), 9187(Cord case), 7243A(L-shaped probe), 8016(Hook type prod) 8212-USB(USB adapter with "KEW Report(Software)")*1					

*1 3552/3552BT only *2 3552BT only, Bluetooth® is a trademark or registered trademark of Bluetooth sig, Inc. Some countries regulate the compliance with their Radio Law of the products equipped with Bluetooth®. Please confirm it with your distributor before purchasing our products equipped with Bluetooth®.
*3 Low-resistance range is protected by a built-in fuse (0.5A/1000V, Dia. 6.3 x 32mm)

Diagnostic Insulation Tests



PI Polarization Index

PI = $\frac{\text{Insulation resistance value 10 min. after start}}{\text{Insulation resistance value 1 min. after start}}$

PI Criteria	4.0 or more Best	4.0-2.0 Good	2.0-1.0 Warning	1.0 or less Bad
-------------	------------------	--------------	-----------------	-----------------

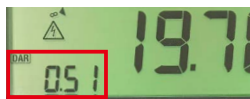

DAR Dielectric Absorption Ratio

DAR = $\frac{\text{Insulation resistance value 1 min. after start}}{\text{Insulation resistance value 15 sec. after start}}$

DAR Criteria	1.4 or more Best	1.25-1.0 Good	1.0 or less Bad
--------------	------------------	---------------	-----------------

LED light & Display backlight

Facilitate working at dimly illuminated location. Automatic sensor turns the LCD backlight and LED spot light ON/OFF.



Memory/data transfer function (available on KEW 3552/3552BT)

Internal memory up to 1000 measurements can be transferred to a PC by the optional adapter 8212-USB.

Accessories



MODEL 7260
Test lead with remote control switch



MODEL 7261A
Test lead with alligator clip



MODEL 8017A
Extension prod long



MODEL 9173
Carrying case

MODEL 9121
Shoulder strap



Optional Accessories



MODEL 7243A
L-shaped probe



MODEL 8212-USB
USB adapter with "KEW Report (Software)"



MODEL 9186A
Carrying case



MODEL 9187
Cord case



MODEL 8016
Hook type prod

ANALOG INSULATION/CONTINUITY TESTERS

MODEL 3131A



- Three insulation test ranges: 250V/100MΩ, 500V/200MΩ, 1000V/400MΩ
- LIVE circuit warning lamp plus audible warning
- Automatic discharge of circuit capacitance when TEST button is released
- Fuse protected (continuity range only)
- Battery check LED
- Zero adjustment on panel
- Backlight function to facilitate working at dimly lit situations
- PRESS TO TEST button with lock down feature

3131A	
Insulation resistance	
Test voltage	250/500/1000V
Measuring ranges (Mid-scale value)	100/200/400MΩ (1/2/4MΩ)
Output voltage on open circuit	Rated test voltage +20%, -0%
Nominal current	1mA DC min.
Output short circuit current	Approx. 1.3 mA DC
Accuracy	0.1 - 10/0.2 - 20/0.4 - 40MΩ (Accuracy guaranteed ranges) ±5% of indicated value
Continuity	
Measuring ranges (Mid-scale value)	2/20Ω (1/10Ω)
Output voltage on open circuit	4 - 9V DC
Measuring current	200mA DC min.
Accuracy	±3% of scale length
General	
Applicable Standards	IEC 61010-1 CAT III 300V Pollution degree 2 IEC 61010-2-034, IEC 61557-1,2,4 IEC 60529(IP54), IEC 61326-1(EMC)
Power source	R6(AA)(1.5V) × 6
Dimension	167(L) × 185(W) × 89(D)mm
Weight	Approx. 860g
Accessories	7122B(Test leads), 9074(Cord case) 8923(Fuse[0.5A/600V]) × 1 (included), 1 (spare) R6(AA) × 6, 9121(Shoulder strap), Instruction manual

MODEL 3132A



- Dust and Drip-proof construction (designed to IEC 60529 IP54)
- Designed to meet IEC 61010-1 and IEC 61557 safety standard
- 1mA rated test current at the minimum resistance
- 200mA measuring current on continuity testing
- Automatic discharge of circuit capacitance (Any charge stored in the circuit under test will be automatically discharged after testing)
- Live circuit warning buzzer and neon lamp
- Small and lightweight. Shock resistant new case material
- AC voltmeter with linear, easy-to-read scale
- Operates on AA, R6 × 6 dry batteries

3132A	
Insulation resistance	
Test voltage	250/500/1000V
Measuring ranges (Mid-scale value)	100/200/400MΩ (1/2/4MΩ)
Output voltage on open circuit	Rated test voltage +20%, -0%
Nominal current	1mA DC min.
Output short circuit current	1 - 2mA DC
Accuracy	0.1 - 10/0.2 - 20/0.4 - 40MΩ (Accuracy guaranteed ranges) ±5% of indicated value
Continuity	
Measuring ranges (Mid-scale value)	3/500Ω (1.5/20Ω)
Output voltage on open circuit	Approx. 4.1V DC
Measuring current	210mA DC min.
Accuracy	±1.5% of scale length
AC voltage	
AC voltage range	0 - 600V AC
Accuracy	±5% of scale length
General	
Applicable Standards	IEC 61010-1 CAT III 600V Pollution degree 2 IEC 61010-2-034, IEC 61557-1,2,4 IEC 60529(IP54), IEC 61326-1(EMC)
Power source	R6(AA)(1.5V) × 6
Dimension	106(L) × 160(W) × 72(D)mm
Weight	Approx. 560g
Accessories	7122B(Test leads)*1, 9074(Cord case) 8923(Fuse[0.5A/600V]) × 1 (included), 1 (spare) R6(AA) × 6, 9121(Shoulder strap), Instruction manual

*1 7217A(For Australia)

Accessories

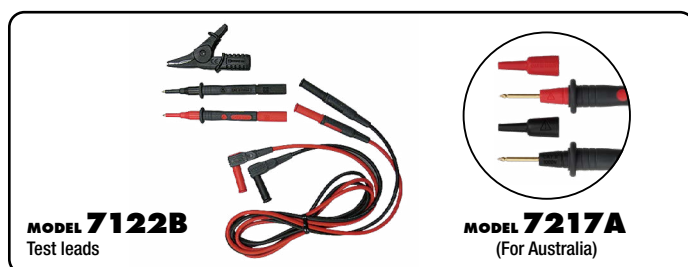

Selection Guide

	3131A	3132A
3 range insulation test voltage	✓	✓
200mA continuity	✓	✓
Live circuit warning	✓	✓
AC voltage range	✓	✓
Illuminated scale	✓	✓
Automatic discharge	✓	✓
IP54 rating	✓	✓

ANALOG INSULATION TESTERS

MODEL 3161A



AC V

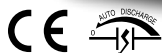

- Compact and lightweight insulation tester
It weighs only 340g(battery included), but carries full measurement functions
- Automatic discharge of circuit capacitance
- Test leads with remote control switch
- New robust housing case
- Backlight function

3161A	
Insulation resistance	
Test Voltage	15/500V
Max. effective scale value	20/100MΩ
Mid-scale value	0.05/2MΩ
First effective measuring range	0.005 - 2/0.1 - 50MΩ
Accuracy	±5% of indicated value
Second effective measuring range	Measuring ranges other than above, 0 and ∞
Accuracy	±10% of indicated value
AC voltage	
AC voltage range	600V
Accuracy	±3% of full scale value
Applicable Standards	IEC 61010-1 CAT III 300V / CAT II 600V IEC 61010-2-034
Power source	R6(AA)(1.5V) × 4
Dimension	90(L) × 137(W) × 40(D)mm
Weight	Approx. 340g
Accessories	7149A(Test leads with remote control switch set) 9123(Shoulder strap) R6(AA) × 4, Instruction manual
Optional Accessories	8016(Hook type prod)

MODEL 3165/3166



AC V

- 500V/1000MΩ (Model 3165)
- 1000V/2000MΩ (Model 3166)
- Expanded megohm scale for easy reading
- New robust housing case to prevent damage
- AC voltmeter scale for easy reading

photo : 3165

	3165	3166
Insulation resistance		
Test voltage	500V	1000V
Max. effective scale value	1000MΩ	2000MΩ
Mid-scale value	20MΩ	50MΩ
First effective measuring range	1 - 500MΩ	2 - 1000MΩ
Accuracy	±5%rdg	
Second effective measuring range	0.5/1000MΩ	1/2000MΩ
Accuracy	±10%rdg	
AC voltage		
AC voltage range	600V	
Accuracy	±3% of full scale value	
Power source	R6(AA)(1.5V) × 4	
Dimension	90(L) × 137(W) × 40(D)mm	
Weight	Approx. 330g	
Accessories	7025(Test leads), 9074(Cord case), 9123(Shoulder strap) R6(AA) × 4, Instruction manual	

KEW 3431



DC AC V

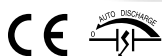

- Compact and lightweight design
- Scale light and LED spot light to facilitate working at dimly illuminated location or at nighttime work
- Built-in illuminance sensor automatically turns lights on and off
- Test lead with remote control switch set is supplied as standard accessory
- Live circuit warning with blinking LED and buzzer

3431		
Insulation resistance		
Test Voltage	250V	500V
Max. effective scale value	200MΩ	2000MΩ
Mid-scale value	5MΩ	50MΩ
First effective measuring range	0.1 - 100MΩ	1 - 1000MΩ
Accuracy	±5% of indicated value	
Second effective measuring range	Measuring ranges other than above, 0 and ∞	
Accuracy	±10% of indicated value	
Voltage measurement		
Voltage	AC 600V (45 - 65Hz)/DC 600V	
Accuracy	±5% of indicated value	
Applicable Standards	IEC 61010-1, 2-030 CAT III 600V Pollution degree 2 IEC 61010-2-034, IEC 61010-031	
Power source	LR6/R6(AA)(1.5V) × 4	
Dimension	97(L) × 156(W) × 46(D)mm	
Weight	Approx. 430g	
Accessories	7260(Test lead with remote control switch) 7261A(Test lead with alligator clip), 9173(Carrying case) 8017A(Extension prod long), 9121(Shoulder strap) LR6(AA) × 4, Instruction manual	
Optional Accessories	9186A(Carrying case), 9187(Cord case) 7243A(L-shaped probe), 8016(Hook type prod)	

INSULATION TESTERS

Why insulation test is necessary?

All live conductors of electrical appliances and installations must be insulated to prevent electric shock hazards from inadvertent contact, fire hazards from short circuit and equipment damage. In addition, a low insulation resistance in installation will result in a leakage current, and hence causes a waste of energy which would increase the running costs of the installation. Insulation resistance must be checked by applying appliances or installations a higher voltage than its normal working voltage,

because an insulation resistance is lower at higher voltage than at lower voltage. Kyoritsu's insulation resistance testers provide measurement at high levels of test voltages. Periodical test is also important to ensure that insulation of installations or appliances is not deteriorating. Foreign matter and mechanical factors like wear or breakage may reduce insulation resistance. Regular tests and data logs can detect possible fault in insulation.

Standards and applications

The International Standard of Electrical Installation of Buildings IEC 60364 has a dedicated section named "Verification". This can be found in part 6. This section stipulates minimum values for the insulation resistance, measured with a particular test voltage, with no equipment connected to the circuits.

Nominal circuit voltage	Test voltage in d.c. applied by Insulation tester	Insulation resistance value
SELV, PELV ($\leq 50V$ a.c. $\leq 120V$ d.c.)	250V	$\geq 0.5M\Omega$
Up to and including 500 V (including FELV) with the exception of the above cases	500V	$\geq 1M\Omega$
Above 500V	1000V	$\geq 1M\Omega$

The testing apparatus (insulation testers) have to be capable of supplying an output current of at least 1mA at its nominal test voltage.

According to IEC 60364, a typical for 230/400V electrical installation (excluding SELV and PELV), requires that the insulation resistance at a test voltage of 500 V d.c. is larger than 1 M Ω .

A test voltage of 1000V can be used for testing the insulation resistance of large electric motors, switchboards, industrial processing machines, devices and circuits with voltages exceeding 500V (but below 1000V a.c. and 1500V d.c.).

A test voltage lower than 250V (for example 15V, 50V, 100V and 125V) may be available in some insulation testers for testing the insulation resistance in telecommunication devices and circuits, security devices, local networks, speech (audio) devices, delicate electronic circuits and PCBs.

Insulation Testing Methods

■ Measurement of Insulation resistance between live conductors (A)

Prior to testing, make sure that the circuit or part of the installation to be tested is disconnected from the mains supply and not energized. It is also necessary to ensure: the point of the installation to be checked is not open due to other equipment incorporated, the load connected with a fixed load and socket outlet is disconnected from the mains supply, and relay coils, fluorescent lamps, etc do not produce continuity between conductors. Circuits or components likely to be damaged by insulation test voltage must be removed from the circuit under test. If they cannot be disconnected, an alternative testing method is to measure insulation resistance between live conductors and earth.

■ Measurement of insulation resistance between live conductors and earth (B)

The test must be carried out with equipment always disconnected, i.e., with the mains switch open it must be disconnected from the mains supply. Earth terminal must be connected to earth and Line terminal to a live conductor or conductors. Where there is insulation deterioration or an indoor electrical installation is not partly or totally insulated a variety of electric hazards may be anticipated.

To give some of the examples;

- Leakage current dangerous to the human body will develop. This is particularly the case with equipment that has no good earth and therefore is not properly protected against the potential difference.
- Overheating of conductors due to the leakage of current or microscopic discharging will cause short circuits or fires.
- RCDs will trip, with resulting damage to the equipment which will also cause short circuits and fires.

Kyoritsu's dedicated leakage clamp meters MODEL 2431, 2432, 2433, 2433R, 2434, KEW 2413F and 2413R will be very helpful in identifying the possible causes of such accidents.

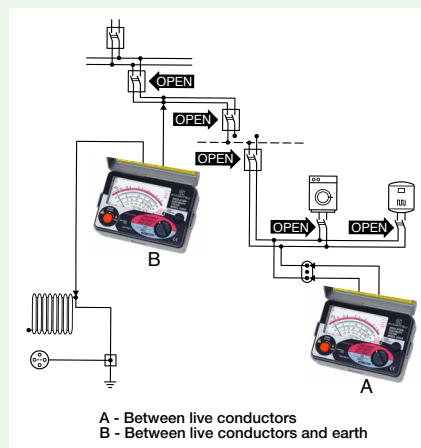

HIGH VOLTAGE INSULATION TESTERS

2500V 5000V
KEW 3121B/3122B



photo : 3121B



photo : 3122B

- Easy and simple operation
- Automatic ranges, indicated by different LEDs
- Newly-designed alligator clip
- It comes with a tough hard case
- Safety standard IEC 61010-1 CAT IV 300V

CE

	3121B	3122B
Test voltage	2500V	5000V
Measuring ranges (automatic change)	2/100GΩ (Auto-ranging)	5/200GΩ (Auto-ranging)
First effective measuring ranges	0.1 - 50GΩ	0.2 - 100GΩ
Accuracy	±5%rdg	
Other ranges accuracy	±10%rdg or 0.5% of scale length	
Short circuit current	0.08mA	
Applicable Standards	IEC 61010-1, IEC 61010-2-030 CAT IV 300V / CAT III 600V Pollution degree 2, IEC 61010-2-034 IEC 61326-1, IEC 61326-2-2(EMC), IEC 60529(IP40)	
Power source	DC12V:LR14 × 8	
Dimension	177(L) × 226(W) × 100(D) mm	
Weight	Approx. 1.6kg	Approx. 1.7kg
Accessories	7165A(Line probe), 7264(Earth cord) 7265(Guard cord), 8019(Hook type prod) 9182(Carrying case[Hard]), LR14 × 8, Instruction manual	7165A(Line probe), 7264(Earth cord) 7265(Guard cord), 8019(Hook type prod) 9183(Carrying case[Hard]), LR14 × 8, Instruction manual
Optional Accessories	7168A(Line probe with alligator clip), 7253(Longer line probe with alligator clip), 8324(Adapter for recorder)	

Accessories



MODEL 7165A
Line probe 3,000mm



MODEL 7264
Earth cord 3,000mm



MODEL 7265
Guard cord 3,000mm



MODEL 8019
Hook type prod



MODEL 9182/9183
Carrying case [Hard]
9182(3121B)/9183(3122B)

Optional Accessories



MODEL 7168A
Line probe with alligator clip 3,000mm



MODEL 7253
Longer line probe with alligator clip 15m



MODEL 8324
Adapter for recorder (Output 10mV/1μA)
Cable length:
200mm connector side
1,100mm alligator clip side

HIGH VOLTAGE INSULATION TESTERS

10000V

KEW 3123A



	3123A	
Test voltage	5000V	10000V
Measuring ranges (automatic change)	5/200GΩ (Auto-ranging)	10/400GΩ (Auto-ranging)
First effective measuring ranges	0.2 - 100GΩ	0.4 - 200GΩ
Accuracy	±5%rdg	
Other ranges accuracy	±10%rdg or 0.5% of scale length	
Power source	R6(AA)(1.5V) × 8	
Dimension	200(L) × 140(W) × 80(D)mm	
Weight	Approx. 1kg	
Accessories	7165A(Line probe), 7224A(Earth cord), 7225A(Guard cord), 8019(Hook type prod), 9158(Carrying case [Hard]), R6(AA) × 8, Instruction manual	
Optional Accessories	7253(Longer line probe with alligator clip), 7168A(Line probe with alligator clip), 8324(Adapter for recorder)	

- Rugged design with a hard carrying case for field use
- Detachable High Voltage Line probe
- Automatic ranges, high and low scales, indicated by different LEDs
- Drip-proof
- Auto-discharge function

Accessories



MODEL 7165A

Line probe 3,000mm



MODEL 7224A

Earth cord 1,500mm



MODEL 7225A

Guard cord 1,500mm



MODEL 8019

Hook type prod



MODEL 9158

Carrying case [Hard]

Optional Accessories



MODEL 7168A

Line probe with alligator clip 3,000mm



MODEL 7253

Longer line probe with alligator clip 15m

MODEL 8324

Adapter for recorder (Output 10mV/1μA)
Cable length:
200mm connector side
1,100mm alligator clip side



Use of Guard Terminal

Illustrated in this Fig. is an example of the insulation resistance measurement of an electric wire. If the line probe is simply connected to the wire conductor and the earth lead to the immersion liquid container as shown, a measurement error will be introduced as this results in the measurement of the combined resistance of insulation resistance and the surface leakage resistance at the cut end of the electric wire. In order to remove this surface leakage current, wind a guard wire around the cut end of the conductor and connect it to the guard terminal of the instrument using the guard lead. Then, the surface leakage current will bypass the indicating resistance meter of the insulation resistance tester.

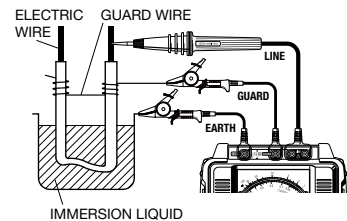

10000V

KEW 3124A



External Power Supply

	3124A	
Test voltage	1 - 10kV variable	1000V
Measuring ranges (automatic change)	1.6/100GΩ (Auto-ranging)	100MΩ
First effective measuring ranges	0.05 - 50GΩ	1 - 100MΩ
Accuracy	±10%rdg	
Other ranges accuracy	±1% of scale length*1	±1% of scale length
Output voltage and set voltage indicate	DC 0 - 10kV ±2%rdg±2dgt	
Power source	Ni-MH rechargeable battery(1.2V) × 8	
Dimension	200(L) × 140(W) × 80(D)mm	
Weight	Approx. 1.6kg	
Accessories	7082(Leads for recorder), 7083(Leads for battery charging), 7084(Earth and guard leads), 9176(Carrying case[Hard]), 8266(Battery charger[120V]) or 8267(Battery charger[220V]) or 8264A(Battery charger[AU]) or 8268(Ni-MH rechargeable battery × 8), Instruction manual	

*1 With measurement voltage less than 2kV, 0 to 100GΩ is not guaranteed accuracy

Accessories



MODEL 7082

Leads for recorder 1,100mm



MODEL 7083

Leads for battery charging 5,200mm



MODEL 7084

Earth and guard leads 5,000mm



MODEL 9176

Carrying case[Hard]

Battery charger

MODEL 8266

120V



OR MODEL 8267

220V



OR MODEL 8264A

AU type



- Permits a wide range of insulation testing up to 100GΩ at variable test voltage from 1kV to 10kV
- DC voltage output for recorders
- Output voltage is shown on the digital display
- After tests, automatically discharges the charges stored in the circuit under test
- Operates with Ni-MH rechargeable batteries

HIGH VOLTAGE INSULATION TESTERS

2500V

5000V

KEW **3025B/3125B**



photo : 3125B



- Large digital display with Bar Graph indication and backlight
- Polarization Index measurement(PI)
- Dielectric Absorption Ratio(DAR)
- Indication of Output voltage and Discharge voltage
- Safety standard IEC 61010-1 CAT IV 300V / CAT III 600V



photo : 3025B



3025B/3125B						
Range	Insulation resistance					Voltage measurement
Test voltage	250V	500V	1000V	2500V	5000V*1	
Measuring range	0.0 - 100.0MΩ	0.0 - 99.9MΩ 80 - 1000MΩ	0.0 - 99.9MΩ 80 - 999MΩ 0.80 - 2.00GΩ	0.0 - 99.9MΩ 80 - 999MΩ 0.80 - 9.99GΩ 8.0 - 100.0GΩ	0.0 - 99.9MΩ 80 - 999MΩ 0.80 - 9.99GΩ 80 - 1000GΩ	30 - 600V AC/DC (50/60Hz)
Accuracy	±5%rdg±3dgt	±5%rdg±3dgt	±5%rdg±3dgt	±5%rdg±3dgt	±5%rdg±3dgt ±20%(100GΩ or more)	±2%rdg±3dgt
Short circuit current	1.5mA					—
Rated test current	0.7 - 0.9mA at 0.25MΩ load	0.8 - 1mA at 0.5MΩ load	1 - 1.2mA at 1MΩ load	1 - 1.2mA at 2.5MΩ load	1 - 1.2mA at 5MΩ load	—
Open circuit voltage	250V +10%,-10%	500V +20%,-10%	1000V +20%,-0%	2500V +20%,-0%	5000V +20%,-0%	—
Applicable Standard	IEC 61010-1, 61010-2-030 CAT IV 300V / CAT III 600V Pollution degree 2, IEC 61010-2-034, IEC 61326-1, 2-2					
Power source	DC12V:LR14 × 8					
Dimension	177(L) × 226(W) × 100(D) mm					
Weight	Approx. 1.7kg (3025B) / Approx. 1.9kg (3125B)					
Accessories	7165A(Line probe), 7264(Earth cord), 7265(Guard cord), 8019(Hook type prod), 9203(Carrying case [Hard] for 3025B) 9204(Carrying case [Hard] for 3125B), LR14(Alkaline battery size C) × 8, Instruction manual					
Optional Accessories	7168A(Line probe with alligator clip), 7253(Longer line probe with alligator clip), 8302(Adapter for recorder)					

*1 3125B only

Accessories



MODEL 7165A
Line probe 3,000mm



MODEL 7264
Earth cord 3,000mm



MODEL 7265
Guard cord 3,000mm



MODEL 8019
Hook type prod



MODEL 9203/9204
Carrying case [Hard]
9203(3025B)/9204(3125B)

Optional Accessories



MODEL 7168A
Line probe with alligator clip 3,000mm

MODEL 7253
Longer line probe
with alligator clip 15m



MODEL 8302
Adapter for recorder
(Output 1mV/1μA)
Cable length:
200mm connector side
1,100mm alligator clip side



HIGH VOLTAGE INSULATION TESTERS

HIGH VOLTAGE INSULATION TESTERS

5000V

KEW 3127

CAT IV 600V DC AC V USB Bluetooth

- Insulation Resistance up to 10TΩ
- Short-Circuit Current up to 5mA
- Wide Test Voltage from 250 to 5000V
- Diagnostic Insulation Tests: IR, PI, DAR, DD, SV, RAMP
- Wireless communication by Bluetooth for transferring and showing real-time data to PC and Android device
- Memory and Logging functions
- Filter function reduces noise interference
- Robust design for field use with IP65 (lid closed)
- Rechargeable battery

Function

PI **DAR** **DD** **SV** **RAMP**



HIGH VOLTAGE INSULATION TESTERS

3127					
Insulation resistance					
Test voltage	250V*1	500V	1000V	2500V	5000V
Max measurement value	9.99GΩ	99.9GΩ	199GΩ	999GΩ	9.99TΩ
Accuracy	0.0 - 99.9MΩ	0.0 - 999MΩ	0.0 - 1.99GΩ	0.0 - 99.9GΩ	0.0 - 99.9GΩ
	±5%rdg±3dgt	±5%rdg±3dgt	±5%rdg±3dgt	±5%rdg±3dgt	±5%rdg±3dgt
	0.1 - 9.99GΩ	1 - 99.9GΩ	2 - 199GΩ	100 - 999GΩ	0.1 - 9.99TΩ
	±20%rdg	±20%rdg	±20%rdg	±20%rdg	±20%rdg
Short circuit current	Max 5.0mA				
Output voltage	Accuracy	-10 - +10%	-10 - +20%	0 - +20%	
	Variable		-		-20% - 0% (by 5%)
	Monitor	±10%rdg±20V			
Measuring range	Voltage measurement		Current measurement	Capacitance measurement	
	AC:30 - 600V (50/60Hz) DC:±30 - ±600V		0.00nA - 5.50mA	5.0nF - 50.0μF*2	
Accuracy	±2%rdg±3dgt		±10%rdg*3	±5%rdg±5dgt	
Power source	Rechargeable Battery (Lead-acid Battery) 12V*4 Charging power : DC 15VA MAX				
Communication Interface	USB, Bluetooth®5.0				
Applicable Standards	IEC 61010-1, IEC 61010-2-030 CAT IV 600V Pollution degree2, IEC 61010-2-034, IEC 61326-1, 2-2				
Dimension	208(L) × 225(W) × 130(D) mm (Hard case 380(L) × 430(W) × 154(D) mm)				
Weight	3127:Approx. 4kg (including battery), Total:Approx. 8kg (including Accessories)				
Accessories	7165A(Line probe), 7224A(Earth cord), 7225A(Guard cord) 8019(Hook type prod), 8327EU(Power adapter 15V/1A), 9171(Carrying case[Hard]), Instruction manual				
Optional Accessories	7168A(Line probe with alligator clip) 7253(Longer line probe with alligator clip), 8258(USB communication set), 8302(Adapter for recorder 1mV/1μA)				

*1 IR mode only *2 At 5000V range 5.0nF-25.0μF *3 Determined by resistance and Voltage values (over 10MΩ) *4 No measurements are possible while charging ※ Bluetooth® is a registered trademark of the Bluetooth SIG, Inc.

Data Communication Function

- Transferring and showing real-time data to PC and Android tablet
- Recorded data can be transferred (PC only)
- Analysis of the saved data (PC only)



※Free Android software is available on download site

Optional Accessories

7168A
(3m)

8258

8302

7253
(15m)

System requirements

OS: Windows® 11/10
Display: XGA (Resolution 1024 × 768 dots) or more
Required HDD space: 1Gbyte or more
Others: With CD-ROM drive and USB port
* Windows® is a registered trademark of Microsoft in the United States.

Diagnostic Insulation Tests

PI Polarization Index

$$PI = \frac{\text{Insulation resistance value 10 min. after start}}{\text{Insulation resistance value 1 min. after start}}$$

PI Criteria	4.0 or more Best	4.0-2.0 Good	2.0-1.0 Warning	1.0 or less Bad
-------------	---------------------	-----------------	--------------------	--------------------

DAR Dielectric Absorption Ratio

$$DAR = \frac{\text{Insulation resistance value 1 min. after start}}{\text{Insulation resistance value *15 sec. after start}}$$

DAR Criteria	1.4 or more Best	1.25-1.0 Good	1.0 or less Bad
--------------	---------------------	------------------	--------------------

*User-Selectable 15sec. or 30sec. interval

DD Dielectric Discharge

$$DD = \frac{\text{Current value 1 min. after completing (mA)}}{\text{Voltage value when a measurement complete (V) × Capacitance (F)}}$$

DD Criteria	2.0 or less Good	2.0-4.0 Warning	4.0-7.0 Poor	7.0 or more Very poor
-------------	---------------------	--------------------	-----------------	--------------------------

HIGH VOLTAGE INSULATION TESTERS

12000V

KEW 3128



CAT IV 600V DC AC V SUN USB AUTO POWER OFF External Power Supply

- Test Voltage 12kV (max), Resistance 35TΩ (max)
- Short-Circuit Current 5mA (max)
- Graphic representation of the insulation resistance and leakage current versus time on large display with bar graph and backlight
- Print Screen Function enables to record up to 32 display screens
- Internal Memory can store about 43,000 data (max)
- Can be operated from internal rechargeable battery or from AC line
- Robust design for field use with IP64 rating (with lid closed)

Function

PI DAR DD SV

		3128					
Insulation resistance	Test voltage	500V	1000V	2500V	5000V	10000V	12000V
	Max measurement value	500GΩ	1TΩ	2.5TΩ	5TΩ	35TΩ	
	Accuracy	400kΩ - 50GΩ ±5%rdg±3dgt	800kΩ - 100GΩ ±5%rdg±3dgt	2MΩ - 250GΩ ±5%rdg±3dgt	4MΩ - 500GΩ ±5%rdg±3dgt	8MΩ - 1TΩ ±5%rdg±3dgt	
		50.1 - 500GΩ ±20%rdg*1	101G - 1TΩ ±20%rdg	251G - 2.5TΩ ±20%rdg	501G - 5TΩ ±20%rdg	1.01 - 10TΩ ±20%rdg	
	Short circuit current	Max 5.0mA					
Load resistor to output rated voltage	0.5MΩ or more	1MΩ or more	2.5MΩ or more	5MΩ or more	20MΩ or more	24MΩ or more	
Output voltage	Rated voltage	500V	1000V	2500V	5000V	10000V	12000V
	Monitor accuracy	±10%±20V					
	Output accuracy	0 - +20%	0 - +10%	0 - +10%	0 - +10%	-5 - +5%	-5 - +5%
Voltage measurement	Selectable range	50 - 600V (in steps of 5V)	610 - 1200V (in steps of 10V)	1225 - 3000V (in steps of 25V)	3050 - 6000V (in steps of 50V)	6100 - 10000V (in steps of 100V)	10100 - 12000V (in steps of 100V)
	DCV : ±30 - ±600V, ACV : 30 - 600V(50/60Hz)						
Current measurement	Measuring range	5.0nA - 2.40mA(Depending on the insulation resistance)					
	Accuracy	±5%rdg±5dgt					
Capacitance measurement	Measuring range	5.0nF - 50.0μF					40.0nF - 1.00μF (Display range : 5.0nF - 60.0μF)
	Accuracy	±5%rdg±5dgt					
General	Applicable Standards	IEC 61010-1 CAT IV 600V Pollution degree 2, IEC 61010-2-034, IEC 61326, IEC 60529(IP64): with the lid closed.					
	Power source	Rechargeable Lead storage battery (12V *Charging time : Approx. 8 hours) / AC Power supply (100V - 240V, 50/60Hz) ※ Continuous measuring time: Approx. 4 hours a load of 100MΩ at the Insulation resistance 12000V Range.					
	Dimension	330(L) × 410(W) × 180(D)mm *Instrument and Hard case					
	Weight	Approx. 9kg (including battery) *Instrument and Hard case					
	Accessories	7170(Power cord[EU]) or 7240(Power cord[UK]), 7224A(Earth cord), 7225A(Guard cord), 7226A(Line probe), 7227A(Line probe with alligator clip) 8029(Extension prod), 8212-USB-W(USB adapter with KEW Windows[Software]), Instruction manual					
	Optional Accessories	7254(Longer line probe with alligator clip)					

*1 Accuracy is not guaranteed with setting of 250V or less. *2 Values are displayed, but accuracy isn't guaranteed

SV SV Measurement (Step Voltage)

During the test, the applied voltage incrementally steps by a certain voltage taking successive 5-time measurement. Degradation of insulation may be doubted when insulation resistances become lower at higher applied voltages.

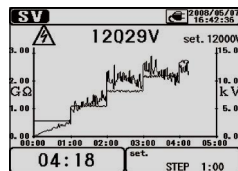

RAMP RAMP TEST

Voltage used in Step voltage test is raised in steps but that used in Ramp measurement is gradually raised.

The KEW 3127 Ramp test generates a rising voltage ramp up to the selected voltage.

[Breakdown Mode]

KEW 3127 automatically stops the test if the insulation breaks down in order to prevent damage to the object being tested.

[Burn Mode]

KEW 3127 allows the insulation test voltage to continue even after the insulation breaks down. This enables you to locate a fault, such as pinholes in windings, by seeing a spark or a wisp of smoke.

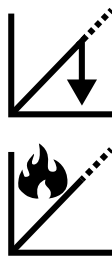

Large Graphical Display

Graphic representation of the insulation resistance and leakage current versus time on large display with bar graph and backlight.

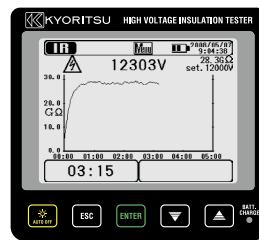

"KEW Windows" Software for report

The stored data can be transferred to PC via MODEL8212-USB-W.



System requirements

OS: Windows® 11/10
Display: XGA (Resolution 1024 × 768 dots) or more
Required HDD space: 100Mbyte or more
Others: With CD-ROM drive and USB port
NET Framework(2.0 or later)
* Windows® is a registered trademark of Microsoft in the United States.

Optional Accessory

MODEL 7254

Longer line probe with alligator clip 15m



EARTH TESTERS

EARTH TESTERS



EARTH TESTERS

Measurement of the earth electrode resistance (3-Pole method)

[MODEL 4102A/KEW 4105A/KEW 4105DL]

The international standard IEC 60364-6 provides information regarding the measurement of the resistance of an earth electrode for TT, TN and IT systems. This measurement shall be made by the Volt-Amperometric method using two auxiliary earth electrodes. The instrument that covers this requirement is the Earth Tester.

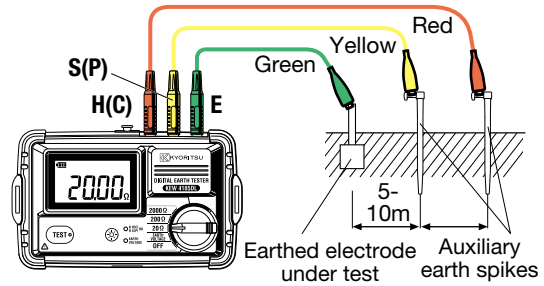

Precise Measurement

Measurement of the simplified earth resistance (2-Pole method)

[KEW 4300/MODEL 4102A/KEW 4105A/KEW 4105DL]

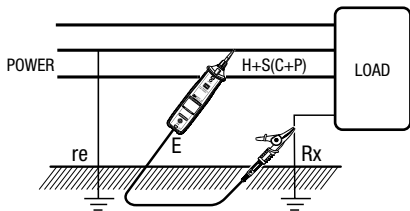

Measuring the earth resistance of load

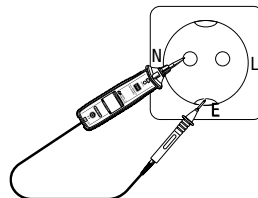

Measuring the earth resistance of wall socket

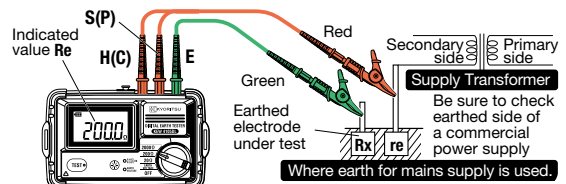

Simplified Measurement

Measurement of the earth resistance with Earth Clamp (Why earth measurements can be found by only clamping it?)

[MODEL 4200/KEW 4202]

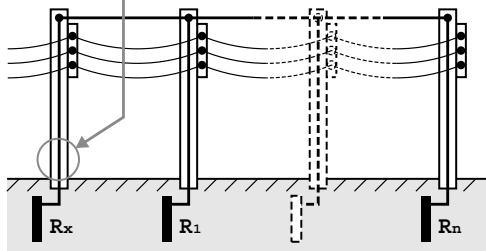
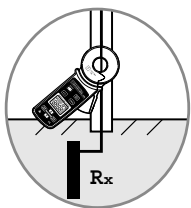

R_x is defined as earth resistance under test, and R₁, R₂...R_n are defined as earth resistance of other measuring objects.

These earth resistances, R₁, R₂,... R_n can be considered that they are connected in parallel. And They can be regarded as a combined resistance R_s. The R_s can be regarded small enough against R_x since a combined resistance consists of several resistances.

Following is an equivalent circuit diagram of this circuit.

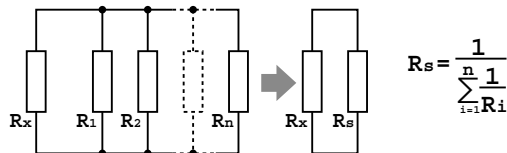

Voltage V is applied to the object (Resistance R_x) measured from the voltage injection transformer CT1, and the current I corresponding to the earth resistance is flowed.

$$\frac{V}{I} = R = R_x + R_s$$

$$R_x \gg R_s = \frac{1}{\sum_{i=1}^n \frac{1}{R_i}}$$

$$\frac{V}{I} = R_x$$

The current I is detected with detection transformer CT2, and object (Resistance R_x) measured can be put out by the calculation. (refer to the right diagram)

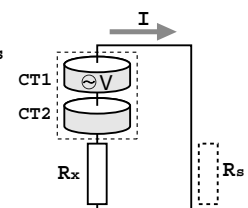

EARTH TESTERS

KEW 4105DL Cable reel set model
KEW 4105DL-H Hard case model



WP

 AUTO POWER OFF

CE

- 3-Pole and 2-Pole Earth Resistance measurement (0.01-2000Ω)
- Waterproof design (IP67)
- Rotary Switch makes the user interface very intuitive
- Large LCD Display with Backlight
- LED to monitor correct / non correct auxiliary earth spike resistance
- Earth Voltage Measurement (AC/DC 0-300V)
- CAT IV 100V

	4105DL/4105DL-H		
Earth resistance measurement	20Ω	200Ω	2000Ω
Measuring range	0.00 - 20.00 Ω	0.0 - 200.0 Ω	0 - 2000 Ω
Display range	0.00 - 20.99 Ω	0.0 - 209.9 Ω	0 - 2099 Ω
Accuracy*1	±1.5%rdg±0.08 Ω*2	±1.5%rdg±4dgt	
Auxiliary earth resistance*3	<10 kΩ	<50 kΩ	<100 kΩ
Comparator reference value	10 Ω	100 Ω	500 Ω
Earth voltage measurement			
Measuring range	0 - 300 V AC (45 - 65Hz) / ±0 - ±300 V DC		
Display range	0.0 - 314.9 V(AC) / 0.0 - ±314.9 V(DC)		
Accuracy	±1%rdg±4dgt		
Overload protection	Earth resistance:360V AC(10 seconds) Earth Voltage:360V AC(10 seconds)		
Applicable Standards	IEC 61010-1 CAT IV 100 V/CAT III 150 V/CAT II 300 V Pollution degree 3 IEC 61010-2-030, IEC 61010-031, IEC 61557-1, 5 IEC 60529 IP67, IEC 61326-1, 2-2		
Power source	LR6(AA)(1.5V) × 6		
Dimension	121(L) × 188(W) × 59(D) mm (including case lid)		
Weight	Approx. 690g (including batteries and case lid)		
Accessories for 4105DL	7127B(Simplified measurement probe) 8041(Auxiliary earth spikes[2spikes/1set]) 9121(Shoulder strap) 7267(Cable reel for Earth resistance tester (Red) 20m) 7268(Cable reel for Earth resistance tester (Yellow) 10m) 7271(Earth resistance test lead (Green) 5m) 9190(Carrying case) , LR6(AA) × 6, Instruction manual		
Accessories for 4105DL-H	7127B(Simplified measurement probe) 8041(Auxiliary earth spikes[2spikes/1set]) 9121(Shoulder strap) 7266(Earth resistance test leads (Red 20m, Yellow 10m, Green 5m/1set)) 9191(Carrying case[Hard]) , LR6(AA) × 6, Instruction manual		
Optional Accessories	7266(Earth resistance test leads (Red 20m, Yellow 10m, Green 5m/1set))*4 7267(Cable reel for Earth resistance tester (Red) 20m)*5 7268(Cable reel for Earth resistance tester (Yellow) 10m)*5 7271(Earth resistance test lead (Green) 5m)*5 9190(Carrying case)*5 9191(Carrying case[Hard])*4 9192(Carrying case for cord reels) 7272(Precision measurement cord set) 7269(Earth resistance test lead (Red 20m)) 7270(Earth resistance test lead (Yellow 10m)) 8259(Adapter for measurement terminal (Red, Yellow, Green/1set))		

*1 For precision measurement, auxiliary earth resistance should be 100 Ω ±5% or less.

*2 At simplified measurement add ±0.10 Ω to the specified accuracy.

*3 Accuracy within the auxiliary earth resistance: ±5% rdg ±10 dgt. *4 4105DL only *5 4105DL-H only

Water and dust proof: after use you can wash it to remove the mud and dust!



Adapter to enable use of other test leads



Innovative Cable reel with wire guide system to facilitate rewinding



Strong noise rejection!

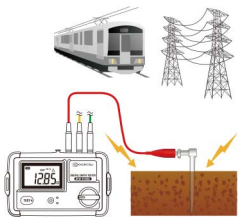

Noise rejection up to 25V rms allows accurate testing in noisy environments.

Earth voltage warning

Red LED lights up if an external voltage is detected.



[LED light comes on if :]

Frequency	Voltage
0 - 10Hz	> 10V
10 - 100Hz	> 25V
100 - 400Hz	> 5V

Robust steel made earth spikes

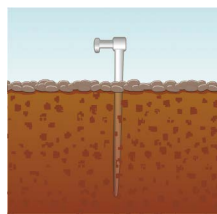

Earth measurements are possible up to 100kΩ* of auxiliary earth pikes resistance.

Auxiliary earth resistance check

If the auxiliary earth resistance is:

Too high at S(P) terminal



Too high at H(C) terminal



Within allowable range (Green LED OK)

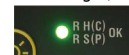

*20Ω range 10kΩ, 200Ω range 50kΩ, 2000Ω range 100kΩ.

EARTH TESTERS

KEW 4105DLBT-H NEW



- 3-Pole and 2-Pole Earth Resistance measurement (0.01-2000Ω)
- Waterproof design (IP67)
- Built-in Bluetooth® enables data transfer
- Noise rejection up to 25V rms allows accurate testing in noisy environments
- Rotary Switch makes the user interface very intuitive
- Large LCD Display with Backlight
- LED to monitor correct / non correct auxiliary earth spike resistance
- Earth Voltage Measurement (AC/DC 0-300V)
- CAT IV 100V



KEW Smart
Advanced

- Simplified monitoring
- Report creation

* Please see P.8 to 9 for details.



4105DLBT-H			
Earth resistance measurement	20Ω	200Ω	2000Ω
Measuring range	0.00 - 20.00 Ω	0.0 - 200.0 Ω	0 - 2000 Ω
Display range	0.00 - 20.99 Ω	0.0 - 209.9 Ω	0 - 2099 Ω
Accuracy*1	±1.5%rdg±0.08 Ω*2	±1.5%rdg±4dgt	
Auxiliary earth resistance*3	<10 kΩ	<50 kΩ	<100 kΩ
Comparator reference value	10 Ω	100 Ω	500 Ω
Earth voltage measurement			
Measuring range	0 - 300 V AC (45 - 65Hz) / ±0 - ±300 V DC		
Display range	0.0 - 314.9 V(AC) / 0.0 - ±314.9 V(DC)		
Accuracy	±1%rdg±4dgt		
Overload protection	Earth resistance:360V AC(10 seconds) Earth Voltage:360V AC(10 seconds)		
Applicable Standards	IEC 61010-1 CAT IV 100 V /CAT III 150 V/CAT II 300 V Pollution degree 3 IEC 61010-2-030, IEC 61010-031, IEC 61557-1, 5 IEC 60529 IP67, IEC 61326-1, 2-2		
Communication Interface	Bluetooth®5.0		
Power source	LR6(AA)(1.5V) × 6		
Dimension	121(L) × 188(W) × 59(D) mm (including case lid)		
Weight	Approx. 690g (including batteries and case lid)		
Accessories	7127B(Simplified measurement probe) 8041(Auxiliary earth spikes[2spikes/1set]) 9121(Shoulder strap) 7266(Earth resistance test leads (Red 20m, Yellow 10m, Green 5m/1set)) 9197(Carrying case[Hard]) LR6(AA) × 6, Instruction manual		
Optional Accessories	7267(Cable reel for Earth resistance tester (Red) 20m) 7268(Cable reel for Earth resistance tester (Yellow) 10m) 7271(Earth resistance test lead (Green) 5m) 9190(Carrying case) 9192(Carrying case for cord reels) 7272(Precision measurement cord set) 7269(Earth resistance test lead (Red) 20m)) 7270(Earth resistance test lead (Yellow) 10m)) 8259(Adapter for measurement terminal (Red, Yellow, Green/1set))		

*1 For precision measurement, auxiliary earth resistance should be 100 Ω ±5% or less.

*2 At simplified measurement add ±0.10 Ω to the specified accuracy.

*3 Accuracy within the auxiliary earth resistance: ±5% rdg ±10 dgt.

Accessories / Optional Accessories



Selection Guide

	4105DL	4105DL-H	4105DLBT-H
Bluetooth® communication	-	-	✓
Accessories(●), Optional Accessories(△)			
① 7127B Simplified measurement probe	●	●	●
② 8041 Auxiliary earth spikes [2spikes/1set]	●	●	●
③ 9121 Shoulder strap	●	●	●
④ 7266 Earth resistance test leads (Red 20m, Yellow 10m, Green 5m/1set)	△	●	●
⑤ 7267 Cable reel for Earth resistance tester (Red) 20m	●	△*	△*
⑥ 7268 Cable reel for Earth resistance tester (Yellow) 10m	●	△*	△*
⑦ 7271 Earth resistance test lead (Green) 5m	●	△	△
⑧ 9190 Carrying case	●	△	△
⑨ 9191 Carrying case[Hard]	△	●	-
⑩ 9197 Carrying case[Hard]	-	-	●
⑪ 9192 Carrying case for cord reels	△	△	△
⑫ 7272 Precision measurement cord set (②8041, ⑤7267, ⑥7268, ⑦7271, ⑪9192)	△	△	△
⑬ 7269 Earth resistance test lead (Red) 20m	△	△	△
⑭ 7270 Earth resistance test lead (Yellow) 10m	△	△	△
⑮ 8259 Adapter for measurement terminal (Red, Yellow, Green/1set)	△	△	△

* The cord reel itself cannot be stored in the hard case.

EARTH TESTERS

MODEL 4102A Soft case model
MODEL 4102A-H Hard case model

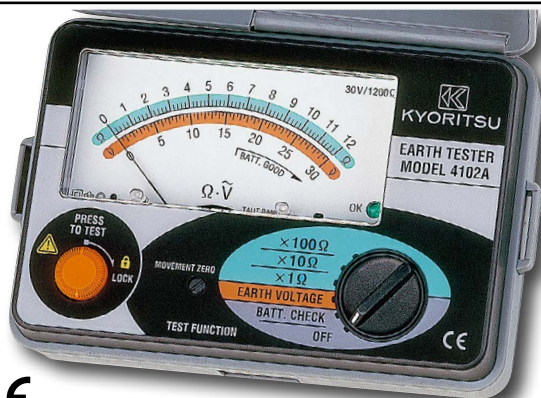

CE

4102A/4102A-H			
Earth resistance measurement	$\times 1\Omega$ Range	$\times 10\Omega$	$\times 100\Omega$
Measuring range	0 - 12 Ω	0 - 120 Ω	0 - 1200 Ω
Accuracy	$\pm 3\%$ of full scale		
Earth voltage measurement			
Measuring range	0 - 30 V AC (50/60Hz)		
Accuracy	$\pm 3\%$ of full scale		
Overload protection	Earth resistance : 276V AC/DC (10 seconds) Earth voltage : 276V AC/DC (10 seconds)		
Applicable Standards	IEC 61010-1 CAT III 300V Pollution degree 2 IEC 61010-2-030, IEC 61557-1, 5, IEC 60529(IP54)		
Power source	R6(AA)(1.5V) $\times 6$		
Dimension	105(L) \times 158(W) \times 70(D) mm (including case lid)		
Weight	Approx. 600g (including batteries and case lid)		
Accessories	7095A(Earth resistance test leads (Red 20m, Yellow 10m, Green 5m/1set)) 7127B(Simplified measurement probe) 8032(Auxiliary earth spikes[2spikes/1set]), 9121(shoulder strap) R6(AA) $\times 6$, Instruction manual 9084(Carrying case for 4102A), 9164(Carrying case [Hard] for 4102A-H)		
Optional Accessories	7245A(Precision measurement cord set) 8259(Adapter for measurement terminal)		

KEW 4105A Soft case model
KEW 4105A-H Hard case model



CE

4105A/4105A-H			
Earth resistance measurement	20 Ω	200 Ω	2000 Ω
Measuring range	0.00 - 1999 Ω		
Display range	0.00 - 19.99 Ω	0.0 - 199.9 Ω	0 - 1999 Ω
Accuracy	$\pm 2\%$ rdg $\pm 0.1 \Omega$	$\pm 2\%$ rdg ± 3 dgt	
Earth voltage measurement			
Measuring range	0 - 200 V AC (50/60Hz)		
Display range	0.0 - 199.9 V		
Accuracy	$\pm 1\%$ rdg ± 4 dgt		
Overload protection	Earth resistance : 280V AC (10 seconds) Earth voltage : 300V AC (1 minute)		
Applicable Standards	IEC 61010-1 CAT III 300V Pollution degree 2 IEC 61010-2-030, IEC 61557-1, 5, IEC 60529(IP54)		
Power source	R6(AA)(1.5V) $\times 6$		
Dimension	105(L) \times 158(W) \times 70(D) mm (including case lid)		
Weight	Approx. 550g (including batteries and case lid)		
Accessories	7095A(Earth resistance test leads (Red 20m, Yellow 10m, Green 5m/1set)) 7127B(Simplified measurement probe) 8032(Auxiliary earth spikes[2spikes/1set]), 9121(shoulder strap) R6(AA) $\times 6$, Instruction manual 9084(Carrying case for 4105A), 9165(Carrying case [Hard] for 4105A-H)		
Optional Accessories	7245A(Precision measurement cord set) 8259(Adapter for measurement terminal)		

Features(4102A/4105A)

- 3-Pole and 2-Pole Earth Resistance
- The latest circuit design permits the instrument to operate with the minimum of influence from earth voltage and earth resistance of auxiliary earth spikes
- Dust and drip proof (designed to IEC 60529 IP54)
- Earth resistance value can be read directly from the scale
- Designed to meet IEC 61010-1 safety standard
- Capable of measuring earth voltage
- Small and lightweight. Shock resistant new case material
- 2mA measuring current permits earth resistance tests without tripping earth leakage current breakers in the circuit under test
- Lead wire connection to C and P terminals and proper auxiliary earth resistance can be checked by "OK" lamp
Lead wire connection to C and E terminals is good when "OK" lamp is illuminated (4102A only)

Optional Accessories



Soft case model



Hard case model



MODEL 7245A
Precision measurement cord set
(7228A, 8032, 8200-03, 9142)

< MODEL 7245A Precision measurement cord set >



MODEL 7228A
Earth resistance test leads



MODEL 8032
Auxiliary earth spikes
[2spikes/1set]



MODEL 8200-03
Cord reels[3pcs]



MODEL 9142
Carrying case



MODEL 8259
Adapter for measurement terminal
[red, yellow, green/1set]

EARTH TESTERS



KEW 4106

CE

- Earth resistance measurement with six ranges covering measurements from 0.001 Ω to 200 kΩ
- Earth resistivity (ρ) measurement is automatically calculated after having set the distance between Auxiliary Earth Spikes (Wenner method)
- Automatic and Manual selection of the Test Current Frequency in four bands of 94/105/111/128Hz
In Automatic mode KEW 4106 will select the most suitable Frequency
- Advanced Filtering method (based on FFT Fast Fourier Transform) reduces noise interference for obtaining stable measurements
- Up to 800 measurement results can be saved in the memory and recalled on the display
- The stored results can be transferred to a PC via USB adapter (Model 8212-USB) by using software "KEW Report" which is included
- Robust design with IP54 protection

		4106		
Function	Range	Resolution	Measuring range	Accuracy
Earth resistance Re (Rg at ρ measurement)	2Ω	0.001Ω	0.03 - 2.099Ω	±2%rdg.±0.03Ω
	20Ω	0.01Ω	0.03 - 20.99Ω	±2%rdg.±5dgt
	200Ω	0.1Ω	0.3 - 209.9Ω	
	2000Ω	1Ω	3 - 2099Ω	
	20kΩ	10Ω	0.03 - 20.99kΩ	
200kΩ	100Ω	0.3 - 209.9kΩ		
Auxiliary earth resistance Rh, Rs				8% of Re+Rh+Rs
Earth resistivity ρ	2Ω	0.1Ω·m - 1Ω·m	0.2 - 395.6Ω·m	ρ=2×π×a×Rg
	20Ω	Auto-ranging	0.2 - 3956Ω·m	
	200Ω		20Ω - 39.56kΩ·m	
	2000Ω		0.2 - 395.6kΩ·m	
	20kΩ		2.0 - 1999kΩ·m	
	200kΩ			
Series interference voltage Ust (A.C only)	50V	0.1V	0 - 50.9Vrms	±2%±2dgt
Frequency Fst	Auto-ranging	0.1Hz, 1Hz	40 - 499.9Hz	±1%±2dgt
Test Current	80mA(max)			
Memory capacity	800 data			
Communication interface	Model 8212-USB Optical Adapter			
LCD	Dot-matrix 192 × 64, monochrome			
Over-range indication	"OL"			
Overload protection	between E-S(P) and between E-H(C) terminals AC280V / 10 sec.			
Applicable Standards	IEC 61010-1 CAT IV 150V / CAT III 300V Pollution degree 2 IEC 61557-1,5, IEC 61326-1(EMC), IEC 60529(IP54)			
Power source	DC12V : sizeAA manganese dry battery (R6) × 8 (Auto power off: Approx. 5 minutes)			
Dimension	167(L) × 185(W) × 89(D)mm			
Weight	Approx. 900g (including batteries)			
Accessories	7229A(Earth resistance test leads) 7238A(Simplified measurement test leads) 8032(Auxiliary earth spikes[2spikes/set]) × 2 8200-04(Cord reels [4pcs]) 8212-USB(USB adapter with "KEW Report(Software)") 8923(Fuse [0.5A/600V]) × 1 (included), 1 (spare) 9121(Shoulder strap), 9125(Carrying case) R6 × 8, Instruction manual			



KEW 4300

SIMPLIFIED EARTH TESTER

CE

		4300
Earth resistance ranges		200.0/2000Ω(Auto-ranging) ±3%rdg±5dgt
Voltage ranges		AC:5.0 - 300.0V(45 - 65Hz) ±1%rdg±4dgt DC:±5.0 - 300.0V ±1%rdg±8dgt
Applicable Standards		IEC 61010-1 CAT III 300V pollution degree 2 IEC 61557-1,5 IEC 61326-1,2-2, IEC 60529(IP40)
Power source		LR6(AA)(1.5V) × 2
Dimension		232(L) × 51(W) × 42(D)mm
Weight		Approx. 220g(including battery)
Accessories		7248(Test lead with Alligator clip and Flat test probe) 8072(CAT II Standard prod) 8253(CAT III Standard prod) 8017(Extension prod long) 9161(Carrying case) Instruction manual, LR6(AA) × 2

KEW 4300 is simplified earth resistance tester (based on 2-pole method) that can be used for various distribution lines and electrical appliances and it also can measure AC/DC voltage. (As for AC voltages, True RMS values can be obtained.)

- 200/2000Ω (2 ranges) : Auto-ranging
- Warning buzzer triggered at 100Ω or less
- LED lights up when a large earth voltage is detected
- Live circuit warning when 30V or higher voltage is detected (KEW 4300 detects voltage even when measuring resistances)
- LED light for illuminating measurement points (It turns on/off automatically in relation to the ambient brightness)
- Small test current (max 2mA) not tripping RCD

EARTH CLAMP TESTERS

MODEL 4200/KEW 4202



photo : 4202

Note: A single earthing can not be measured. (Only for Multiple Earthing system)

- The earth resistance from 0.05 to 1500Ω can be measured without the auxiliary earth spikes in multi-earthing systems
- True RMS leakage or phase current readings from 0.1mA to 30.0A provides vital additional information in earthing networks
- Filter function offers increased immunity to electrical noise and a Noise mark appears in excessively high noisy environments
- Memory function up to 100 data
- Bluetooth® communication (4202 only)

	4200	4202
Earth resistance (Auto-ranging)	20.00/200.0/1500Ω ±1.5%±0.05Ω(0.00 - 20.99Ω)*1 ±2%±0.5Ω(16.0 - 99.9Ω) ±3%±2Ω(100.0 - 209.9Ω) ±5%±5Ω(160 - 399Ω) ±10%±10Ω(400 - 599Ω) Values are displayed, but accuracy isn't guaranteed(600 - 1580Ω)	
AC current (50/60Hz) (Auto-ranging)	100.0/1000mA/10.00/30.0A ±2%±0.7mA(0.0 - 104.9mA) ±2%(80mA - 31.5A)	
Operating indication	Earth resistance function : Constant voltage injection Current detection (Frequency : Approx.2400Hz) Dual Integration AC current function : Successive approximation	
Over-range indication	"OL" is displayed when input exceeds the upper limit of a measuring range	
Response time	Approx. 7 seconds (Earth resistance) Approx. 2 seconds (AC current)	
Sample rate	Approx. 1 times per second	
Communication Interface	—	Bluetooth®5.0
Power source	LR6/R6(AA)(1.5V) × 4	
Current consumption	Approx. 50mA (max.100mA)	Approx. 50mA (max.100mA)
Measurement time	Approx.12 hours (when R6 is used) Approx.24 hours (when LR6 is used)	Approx.5 hours (when R6 is used) Approx.21 hours (when LR6 is used)
Auto power off	Turns power off about 10 minutes after the last button operation.	
Applicable Standards	IEC 61010-1 CAT IV 300V Pollution degree2 IEC 61010-2-032, IEC 61326(EMC)	
Conductor size	Approx. φ32mm	
Dimension	246(L) × 120(W) × 54(D)mm	
Weight	Approx. 780g (including batteries)	
Accessories	R6(AA) × 4, Instruction manual 8304 (Resister for operation check) 9166 (Carrying case[Hard])	R6(AA) × 4, Instruction manual 8304 (Resister for operation check) 9167 (Carrying case[Hard])

* Crest factor ≤ 2.5 (50Hz/60Hz, peak value shall not exceed 60A)

*1 4 counts or less are corrected to 0.

Various useful functions are available on Android™ devices using Bluetooth® communication(4202 only)

Free Android software "KEW Smart 4202" is available on download site



Download



KEW Smart 4202

※Communication charges may be incurred separately to download application

Recorded data can be transferred (up to 100 measurements)



Measured data with time and location info can be sent by E-mail

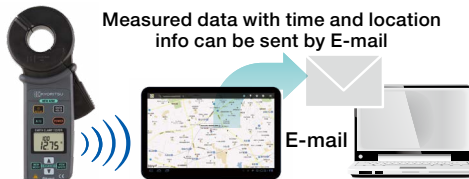

GPS data collection may be lost since the GPS signal differs depending on the location of satellites.
To access GPS data and send emails, an Internet connection is required.
Communication charges may be incurred separately for using these functions.

Comparator function informs when the measured value is lower/higher than the preset value

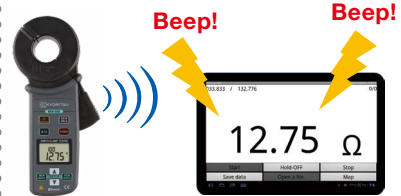

Accessories

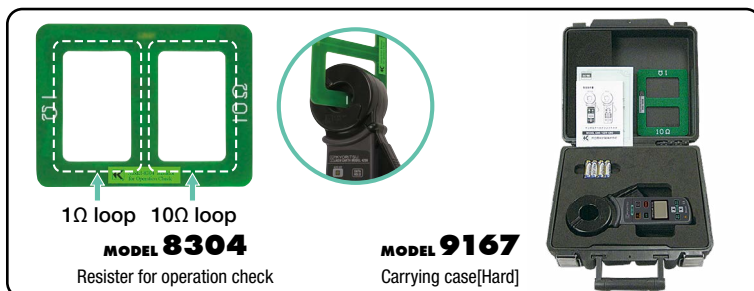

※ Available on the Android devices equipped with Bluetooth®/ GPS/ Data communication function.

Max communication distance :10m

Bluetooth® is a registered trademark of the Bluetooth SIG, Inc.

Android is a registered trademark of the Google Inc.

Earth Clamp Line up

	4200	4202
Common functions	Earth resistance, AC current, Backlight function, Data hold function, Auto power off, Memory function	
Individual functions	—	Bluetooth® communication

LOOP/PSC TESTERS

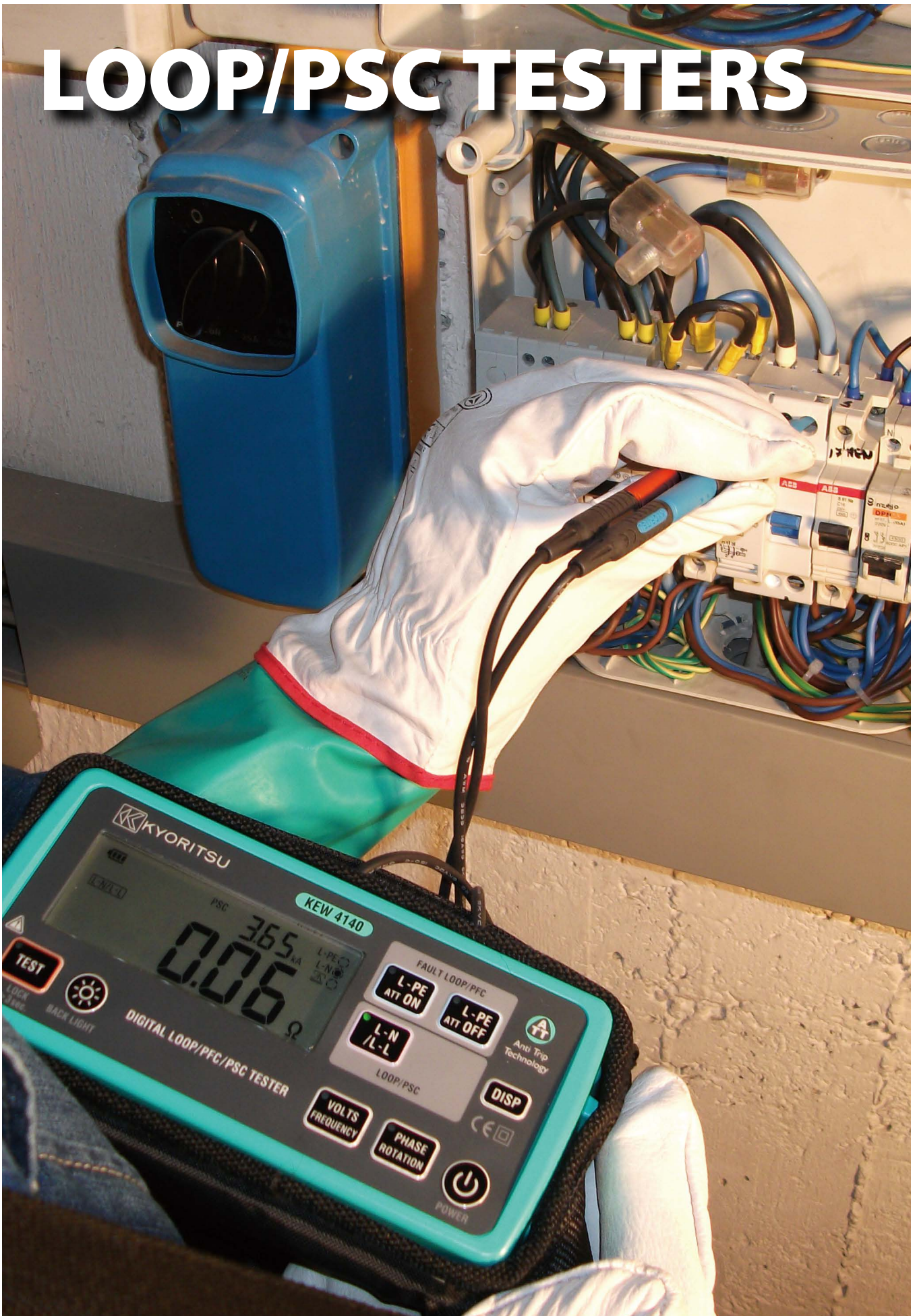

LOOP/PSC TESTERS

MODEL 4118A

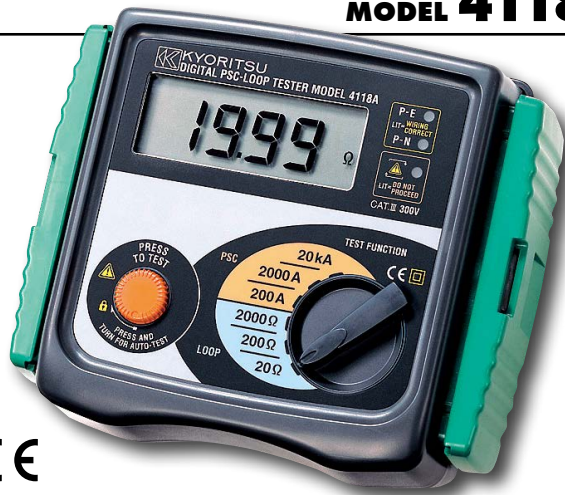

	4118A
Loop impedance ranges	20/200/2000Ω
Loop impedance accuracy	±2%rdg±4dgt
AC test current	20Ω 25A 200Ω 2.3A 2000Ω 15mA
AC test period	20Ω (20ms) 200Ω (40ms) 2000Ω (280ms)
PSC ranges	200A(2.3A 40ms) 2000A(25A 20ms) 20kA(25A 20ms)
PSC ranges accuracy	Consider accuracy of loop impedance
Voltage	110 - 260V ±2%rdg±4dgt
Operating voltage	230V +10%, -15%(195 - 253V)50Hz
Applicable Standards	IEC 61010-1 CAT III 300V Pollution degree 2 IEC 61557-1,3, IEC 60529(IP54)
Dimension	167(L) × 186(W) × 89(D)mm
Weight	Approx. 750g
Accessories	Molded plug test lead*1 7121B(Distribution board test leads) 9147(Cord case) 9121(Shoulder strap) Instruction manual

*1 7123(AU): Australian plug 7124(UK): British plug(13A)
7125(EU): European SCHUKO plug 7126(SA): South african plug

- Custom microprocessor controlled for highest accuracy and reliability
- 3 LEDs for checking correct wiring status
- 15mA LOOP measurement: LOOP impedance 2000Ω range measurement is carried out with low test current (15mA)
The current will not cause tripping out involved RCD even the one with the lowest nominal differential current (30mA)
- Direct reading of Prospective Short Circuit Current (PSC)
- Measure low loop resistances(resolution of 0.01Ω)
- Automatic lock-out if test resistor overheats
- Large custom digital display readout
- Visual indication of reversed phase and neutral wiring at socket
- Designed to IP54 Rating

Accessories



MODEL 7121B
(Distribution board test leads)



Molded plug test lead

- MODEL 7123** (AU) Australian plug
- MODEL 7124** (UK) British plug(13A)
- MODEL 7125** (EU) European SCHUKO plug
- MODEL 7126** (SA) South african plug

Loop Testing Methods

In the buildings mainly used for private residence where low voltage power is supplied from electric utilities the fundamental protection against electric shock hazards is provided by appropriately coordinating the function of an earthing circuit with automatic switches placed at the latter stage of indoor wiring circuits. This is intended to quickly cut off the supply to an earthing circuit where a fault occurs following touch voltage exceeding an acceptable limit. Proper protection against electric shock hazards is given when the TT wiring system satisfies the requirement as expressed by the following formula:

$$R_a \times I_a \leq 50$$

where R_a is the sum of the resistances of earth bars and protective conductors and I_a is the maximum current of a protection system provided for installations, indicating that the value obtained by multiplying R_a with I_a is not more than 50V. This means a maximum voltage one can touch shall not exceed 50V in the event of an earth fault.

- Method of earth fault loop impedance testing at socket outlet. As shown in Fig., total earth fault loop impedance can be measured by plugging a loop tester into socket. The value of earth fault loop impedance measured represents the sum of transformer coil winding resistance, phase conductor (L3) resistance and protective conductor (PE) resistance as well as source earth resistance and installation earth resistance. With the loop tester set to any one of the PSC (prospective short circuit current) range, it is also possible to measure earth fault current.

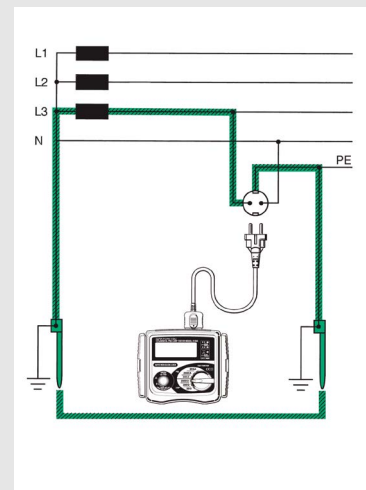

Fig. Earth fault loop impedance testing at socket outlet.

LOOP/PSC TESTERS

KEW 4140



- Anti-Trip Technology for complete trip free Loop testing on all RCDs rated 30mA and above
- Dual Display allows simultaneous measurements like Loop & PFC/PSC
- Two wire connection for Loop L-L, L-N and PSC testing is possible
- Phase rotation, Voltage and Frequency measurements
- Lock-down test button for 'hands free' testing with auto-start operation
- Display and front panel keyboards with Backlight to be visible in dark places
- Water and Dust proof (IP54)



4140			
Loop Impedance			
Function	L-PE ATT OFF	L-PE ATT ON	L-N/L-L
Rated voltage	230V (50/60Hz)		L-N: 230V (50/60Hz) L-L: 400V (50/60Hz)
Operating Voltage	100 - 280V (45 - 65Hz)		100 - 500V (45 - 65Hz)
Range (Auto-Ranging)	20/200/2000Ω	20/200/2000Ω (L-N<20Ω)	20Ω
Nominal Test Current at 0Ω External Loop: Magnitude/Duration at 230V	20Ω:6A/20ms 200Ω:3A/20ms 2000Ω:15mA/250ms	L-N:6A/60ms N-PE:10mA/Approx. 5s	20Ω:6A/20ms
Accuracy	±3%rdg±4dgt*1	±3%rdg±6dgt*1	L-N: ±3%rdg±4dgt L-L: ±3%rdg±8dgt
PFC(L-PE)/PSC(L-N/L-L)*2			
Function	PSC/PFC	PSC/PFC (ATT)	PSC
Rated voltage	230V (50/60Hz)		L-N: 230V (50/60Hz) L-L: 400V (50/60Hz)
Operating Voltage	100 - 280V(45 - 65Hz)		100 - 500V(45 - 65Hz)
Range (Auto-Ranging)	2000A/20kA	2000A/20kA(L-N<20Ω)	2000A/20kA
Nominal Test Current at 0Ω External Loop: Magnitude/Duration at 230V	20Ω:6A/40ms 200Ω:2A/20ms 2000Ω:15mA/500ms	L-N:6A/60ms N-PE:10mA/Approx. 5s	20Ω: 6A/20ms
Phase Rotation			
Operating Voltage	50 - 500V, 45 - 65Hz		
Remarks	Correct phase sequence : displayed "1.2.3" and ⌚ mark Reversed phase sequence : displayed "3.2.1" and ⌚ mark		
Volts			
Function	Volts	Frequency	
Measuring range	0 - 500V	45 - 65Hz	
Accuracy	±2%rdg±4dgt	±0.5%rdg±2dgt	
Applicable Standards	IEC 61010-1 CAT III 300V (500V L to L) IEC 61557-1,3,7,10, IEC 60529 (IP54), IEC 61326(EMC)		
Power source	LR6/R6(AA)(1.5V) × 6 *Use of alkaline batteries (LR6) is recommended.		
Dimension	84(L) × 184(W) × 133(D)mm		
Weight	Approx. 860g (including batteries)		
Accessories	Mains test lead*3, Distribution board test lead*4, 9155 (shoulder strap), 9156A (Soft case) LR6 (AA) × 6, Instruction manual		

*1 Accuracy of L-N LOOP displayed on the Sub Display is synchronized with the one at L-N/L-L function.

*2 PSC/PFC Accuracy is derived from measured loop impedance specification and measured voltage specification.

*3 7187A:(UK)British plug, 7218A:(EU)European SCHUKO plug, 7221A:(SA)South african plug, 7222A: (AU)Australian plug

*4 7246 : Blue, Green, Red, 7247 : Black, Green, Red

Accessories



Mains test lead

MODEL **7187A**

MODEL **7218A** (EU)European SCHUKO plug

MODEL **7221A** (SA)South african plug

MODEL **7222A** (AU)Australian plug



Distribution board test lead

MODEL **7246** Blue, Green, Red

MODEL **7247** Black, Green, Red



MODEL **9156A**

Soft case

RCD TESTERS

MODEL 5406A



- Custom microprocessor controlled for highest accuracy and reliability
- 3 LEDs for checking correct wiring status
- 0 and 180 degree phase angle switch permits quick tests and consistent readings
- Digital read-out of tripping time
- Test of a large kind of RCDs : Standard, Selective, AC and A(DC sensitive breakers)
- Constant current source circuitry ensures that a fluctuating mains voltage does not affect the accuracy of readings
- Large custom digital display readout
- Visual indication of reversed phase and neutral wiring at socket
- Designed to IP54 Rating
- Complies with IEC 61557

5406A	
Rated tripping current	10/20/30/200/300/500mA
Fault condition settings	× 1/2 × 1 × 5 × DC Auto Ramp
Trip current duration	1000ms 200ms(× 5)
Lowest resolution	1ms
Trip time accuracy	±0.6%rdg±4dgt
Operating voltage	230V±10-15% (195 - 253V)[50Hz]
Applicable Standards	IEC 61557-1,6 IEC 61010-1 CAT III 300V Pollution degree 2 IEC 61010-031 IEC 60529(IP54)
Dimension	167(L) × 186(W) × 89(D)mm
Weight	Approx. 800g
Accessories	Molded plug test lead*1, 9147(Cord case) 9121(Shoulder strap), Instruction manual
Optional Accessories	7121B(Distribution board test leads)

*1 7123(AU) : Australian plug 7124(UK) : British plug(13A)
7125(EU) : European SCHUKO plug 7126(SA) : South african plug

Accessories

Molded plug test lead

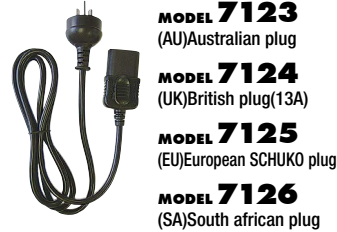

Optional Accessory



KEW 5410



- **Measurement of RCD trip time**
Conducting testing of rated residual non-operating currents at × 1/2 Range, measuring RCD trip time at × 1 and × 5 Ranges
- **Measurement of trip out current**
Measuring trip out current by varying current automatically
- **Remote Test**
Enabling a user to hold the Test Leads with his both hands by locking the Test Button Measurement will automatically start when the main voltage is detected
- **Voltage Measurement**
Carrying out a constant measurement of voltage in the stand-by mode at each Range
- **Auto-detection of Contact voltage**
Detecting the voltage to earth of Earth electrodes or Protective conductors during RCD test - when applying test currents - at measurement using EARTH in order to prevent electrical shocks caused by the damaged earth
Measurement will be ceased at AC50V or more
- **Dust and Water proof**
Dust and Water proof construction (designed to IEC 60529 IP54)
- **Backlight**
Facilitating working at dimly illuminated locations

		5410			
Measurement of RCD trip time		Measurement of trip out current			
Range	× 5	× 1	× 1/2	Auto Ramp (mA)	
Rated voltage	100V±10%, 200V±32%/-10%, 400V±10%, (50/60Hz)				
Test current	15/30/50/100mA		15/30/50/100/200/500mA		
Measuring range	Testing time	Testing time		40 - 110% of IΔn (goes up by 5%)	
	200ms	2000ms		Testing time 300ms × 15 steps	
Accuracy	Trip time	±1%rdg±3dgt			Test current at each step -4 - +4%
	Test current	+2 - +8%dgt		-8 - -2%dgt	
Voltage measurement					
Measuring range	80 - 450V(50/60Hz)				
Accuracy	±2%rdg±4dgt				
Applicable Standards	IEC 61010-1 CAT III 300V / CAT II 400V Pollution degree 2 IEC 61557-1,6 IEC 60529(IP54)				
Operating temperature and humidity range	0 - 40°C, relative humidity 85%(no condensation)				
Storage temperature and humidity range	-20 - 60°C, relative humidity 75%(no condensation)				
Power source	R6(AA)(1.5V) × 8				
Dimension	167(L) × 186(W) × 89(D)mm				
Weight	Approx. 965g (including batteries)				
Accessories	7128A(Test leads), 7129A(Test lead with alligator clip) 8017(Extension prod long) × 2, 9147(Cord case), 9121(Shoulder strap), Instruction manual, R6(AA) × 8				

*Only the RCD type G (without trip out time-delay) can be tested at Auto Ramp Test ; type S (time-delay) cannot be tested.

Accessories



PORTABLE APPLIANCE TESTER

PORTABLE APPLIANCE TESTER



PORTABLE APPLIANCE TESTER

PORTABLE APPLIANCE TESTER

KEW 6205

RMS USB



CE

- Battery operated
- PASS/FAIL result
- Color status backlight
- 10mA & 30mA RCD test (Isolation transformer built in)
- Memory function up to 999 data
- Printer output

*KEW 6205 equipped with Wireless LAN: available only in Australia and New Zealand.

The KEW 6205 is a hand-held portable appliance tester and can test electrical safety of Class I and Class II appliances. The Tester performs test and indicates PASS/FAIL result complying with the criteria of judgment defined in the AS/NZS 3760:2010 for in-service safety inspection and testing of electrical equipment.

Test Function

Function	Tests of contents
Class I Test	<ul style="list-style-type: none"> • Protective conductor resistance (Test current 200mA DC nominal) • Insulation resistance test (250 or 500V) • Leakage current test (100-253V/50Hz) • Load current test (100-253V/50Hz)
Class II Test	<ul style="list-style-type: none"> • Insulation resistance test (250 or 500V) • Leakage current test (100-253V/50Hz) • Load current test (100-253V/50Hz)
Extension Lead Test	<ul style="list-style-type: none"> • Protective conductor resistance (Test current 200mA DC nominal) • Insulation resistance test (between Line/Neutral-Earth short, Line/Neutral) • Leakage current test (100-253V/50Hz) • Polarity test
RCD Test	<ul style="list-style-type: none"> • RCD test (10/30mA)

Accessories

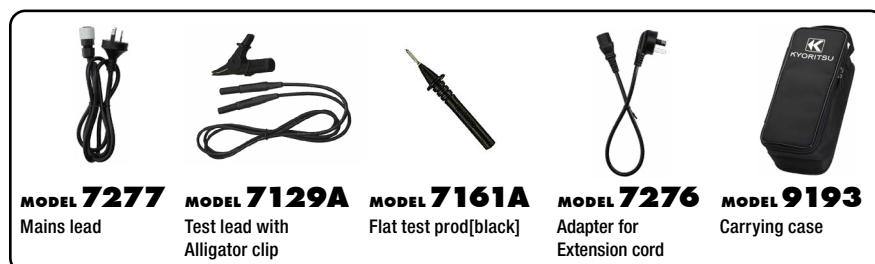

MODEL 7277 Mains lead
MODEL 7129A Test lead with Alligator clip
MODEL 7161A Flat test prod[black]
MODEL 7276 Adapter for Extension cord
MODEL 9193 Carrying case

6205	
Mains voltage indication	
Display range	30-270V
Accuracy	±5V
Protective conductor resistance test	
Measuring range	0.00-20.00Ω
Open circuit voltage	5V±0.4V DC
Measuring current	200mA DC(nominal value)
Accuracy	±3%rdg±5dgt
Insulation resistance test	
Rated voltage	250V 500V
Measuring range	0.00-20.00MΩ
No-load voltage	250V DC +20%,-0% 500V DC +20%,-0%
Short circuit current	1.5mA DC or less
Accuracy	±2%rdg±3dgt
Load current/Leakage current test	
Item	Load current Leakage current
Mains voltage range	100-253V/50Hz
Measuring range	0.10-10.00A rms 0.10-20.00mA rms
Accuracy	±10%rdg±5dgt ±3%rdg±5dgt
RCD test	
Rated voltage	230V -15% - +10%/50Hz
Rated current	10/30mA
Function	× 1 × 5
Test duration	0.0-500.0ms 0.0-40.0ms
Operating time accuracy	±2ms(≤ 40ms), ±8ms(>40ms)
Power source	LR6(AA)(1.5V) × 6
Applicable Standards	IEC 61010-1 CAT II 300V, IEC 61010-2-030, IEC 61010-2-034 IEC 61010-031, EN 61326-2-2, AS / NZS3760
Dimension	261(L) × 104(W) × 57(D)mm
Weight	Approx. 940g(including batteries)
Accessories	7277(Mains lead), 7129A(Test lead with Alligator clip) 7161A(Flat test prod[black]), 7276(Adapter for Extension cord) 9193(Carrying case), 8928(Fuse[10A/250V]) 9121(Shoulder strap), Buckle, LR6(AA) × 6 Instruction manual
Optional Accessories	8263-USB (USB cable with "KEW Report(software)") 7275(Printer cable:Mini Din 6pin - D-sub 9pin) 7248(Test lead with Alligator clip and Flat test probe)

Color status backlight

PASS / FAIL result complying with AS/NZS 3760



PASS

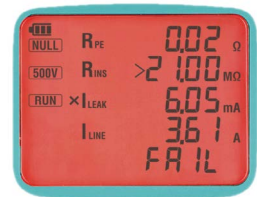

FAIL

Optional Accessories

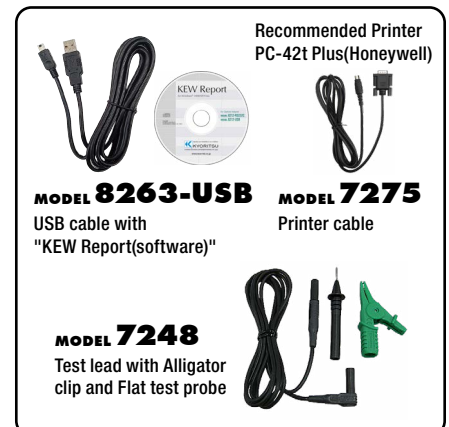

Recommended Printer PC-42t Plus(Honeywell)
MODEL 8263-USB USB cable with "KEW Report(software)"
MODEL 7275 Printer cable
MODEL 7248 Test lead with Alligator clip and Flat test probe

MULTI FUNCTION TESTERS



MULTI FUNCTION TESTERS

MULTI FUNCTION TESTERS

KEW 6010B

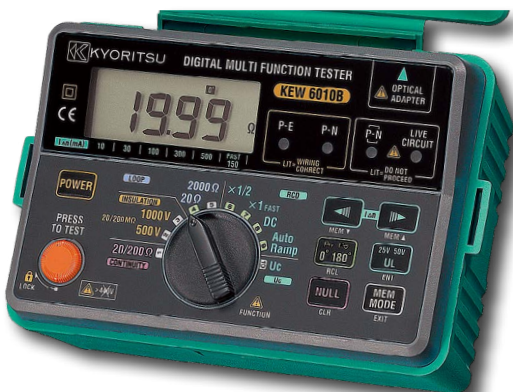

- Designed to IEC 61010-1, IEC 61557
- Data Memory : 300 measured results
- Download results to PC by using 8212 data communication adapter through optical RS-232C port

5 in 1

Continuity

20/200Ω

Loop

20/2000Ω

Uc

100V

Insulation

500/1000V

RCD

10/30/100/300/500mA

Accessories



MODEL 7122B
Test leads

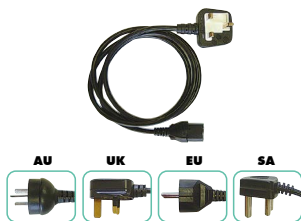

KAMP10
Test lead with IEC connector

Optional Accessories



MODEL 7133B
Distribution board test leads



MODEL 8212-USB
USB adapter with "KEW Report (Software)"

"KEW Report" Software for report

"KEW Report" transfers measurement data from the KEW6010B to a PC via MODEL 8212-USB

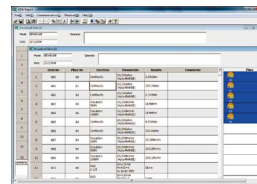

Specifications

	MODEL 8212-USB
Communication method	USB
Driver type	Virtual COM port
Communication speed	19200bps max.
Dimension	Adapter : 53(L) × 36(W) × 19(D)mm Cable : Approx. 2m
Operating temperature and humidity range	-10 - 50°C, 85% RH or less (no condensation)
Storage temperature and humidity range	-20 - 60°C, 85% RH or less (no condensation)

System requirements

OS: Windows® 11/10
Display: XGA (Resolution 1024 × 768 dots) or more
Required HDD space: 20Mbyte or more
Others: With CD-ROM drive and USB port

* Windows® is a registered trademark of Microsoft in the United States.

	6010B	
Continuity testing		
Measuring range	20/200Ω (Auto-ranging)	
Open circuit voltage	>6V	
Short circuit current	>200mA	
Accuracy	±3%rdg±3dgt	
Insulation testing		
Measuring range	20/200MΩ(Auto-ranging)	
Test voltage	500/1000V	
Open circuit voltage	+20%, -0%	
Rated current	>1mA	
Accuracy	±3%rdg±3dgt	
LOOP Impedance testing		
Impedance range	20/2000Ω	
Rated voltage	230V +10%, -15% [50Hz]	
Normal test current	20Ω: 25A/10ms 2000Ω: 15mA/350ms max.	
Accuracy	±3%rdg±8dgt	
RCD testing		
Test current (Test current duration)	× 1/2, × 1	10, 30, 100, 300, 500mA (2000ms)
	FAST	150mA(50ms)
	DC	10,30,100,300mA (2000ms), 500mA(200ms)
	Auto ramp	Goes up by 10% from 20% to 110% of IΔn. 300ms × 10
Rated voltage		230V+10%, -15% [50Hz]
Accuracy	Test current	×1/2 : -8 - -2% ×1, Fast : 2 - 8%
	Trip time	DC : ±10% Auto ramp: ±4%
Uc testing		
Measuring range		100V
Rated voltage		230V +10%, -15% [50Hz]
Test current		5mA at IΔn=10mA
		15mA at IΔn=30/100mA
		150mA at IΔn=300/500mA
Accuracy		+5% to +15%rdg±8dgt
General		
Applicable Standards		IEC 61010-1 CAT III 300V Pollution degree 2 IEC 61010-2-034, IEC 61557-1,2,3,4,6,10, IEC 60529 (IP40)
Power source		R6/LR6 × 8
Dimension		115(L) × 175(W) × 86(D) mm
Weight		Approx. 840g
Accessories		7122B (Test leads), KAMP10 (Test lead with IEC connector)*1 8923 (Fuse[0.5A/600V] × 1 (included), 1 (spare) 9092 (Cord case), 9121 (Shoulder strap), Shoulder pad Instruction manual, R6(AA) × 8
Optional Accessories		7133B (Distribution board test leads) 8212-USB (USB adapter with "KEW Report (Software)")

*1 KAMP10(EU):European SCHUKO plug KAMP10(UK):British plug(13A)
KAMP10(AU):Australian plug KAMP10(SA):South african plug

MULTI FUNCTION TESTERS

MODEL 6011A

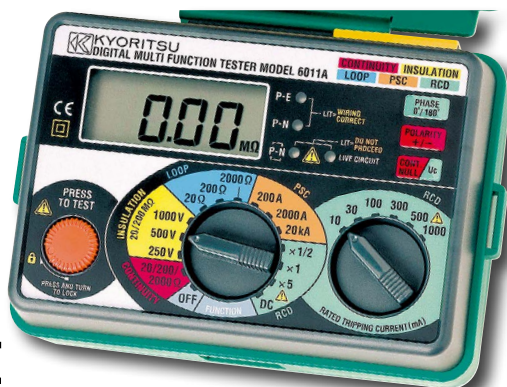

CE

MODEL 6011A can perform FIVE separate test functions: insulation, continuity, earth loop impedance, prospective short circuit current and RCD trip testing in full compliance with IEC 61557

5 in 1

Continuity

20/200/2000Ω

Loop

20/200/2000Ω

PSC

200/2000A/20kA

Insulation

250/500/1000V

RCD

10/30/100/300/500/1000mA

	6011A
Continuity testing	
Measuring ranges	20/200/2000Ω(Auto-ranging)
Open circuit voltage	>6V
Short circuit current	>200mA DC
Accuracy	±1.5%rdg±3dgt
Insulation testing	
Measuring ranges	20/200MΩ(Auto-ranging)
Test voltage	250/500/1000V DC
Output voltage on open circuit	250V+40%, -0% 500V+30%, -0% 1000V+20%, -0%
Rated current	> 1mA
Accuracy	±1.5%rdg±3dgt
Loop impedance testing	
Rated voltage	230V AC +10%, -15%(50Hz)
Voltage measuring range	100 - 250V AC[50Hz]
Impedance ranges	20/200/2000Ω
Nominal test current	25A(20Ω range) 15mA(200Ω range) 15mA(2000Ω range)
Accuracy	20Ω range ±3%rdg±4dgt 200Ω range ±3%rdg±8dgt 2000Ω range ±3%rdg±4dgt
PSC testing	
Rated voltage	230V AC +10%, -15%(50Hz)
PSC ranges	200A(15mA Test current) 2000A(25A Test current) 20kA(25A Test current)
Accuracy	PSC accuracy derived from measured loop impedance specification and measured voltage specification
RCD testing	
Rated voltage	230V AC +10%, -15%(50Hz)
Trip current settings	RCD × 1/2 :10,30,100,300,500,1000mA RCD × 1 : 10,30,100,300,500,1000mA RCD × 5 : 10,30,100,300mA (on × 5 range max current 1A)
Trip current duration	RCD × 1/2 × 1 : 2000ms RCD fast : 50ms
Accuracy	Trip current +10% -0% of test current at 230V Trip time ±1%rdg±3dgt
General	
Applicable Standards	IEC 61010-1 CAT III 300V pollution degree 2 IEC 61010-2-034, IEC 61557, IEC 60529(IP54)
Power source	R6/LR6 × 8
Dimension	130(L) × 183(W) × 100(D)mm
Weight	Approx. 1100g
Accessories	KAMP10(Test lead with IEC connector)*1 7122B(Test leads), 7132A(KSLP5)(External earth probe) 8923 (Fuse[0.5A/600V]) × 1 (included), 1 (spare) 9092(Cord case), 9121(Shoulder strap) R6(AA) × 8, Instruction manual
Optional Accessories	7133B(Distribution board test leads)

*1 KAMP10(EU): European SCHUKO plug KAMP10(UK):British plug(13A)
KAMP10(AU):Australian plug KAMP10(SA):South african plug

MODEL 6018

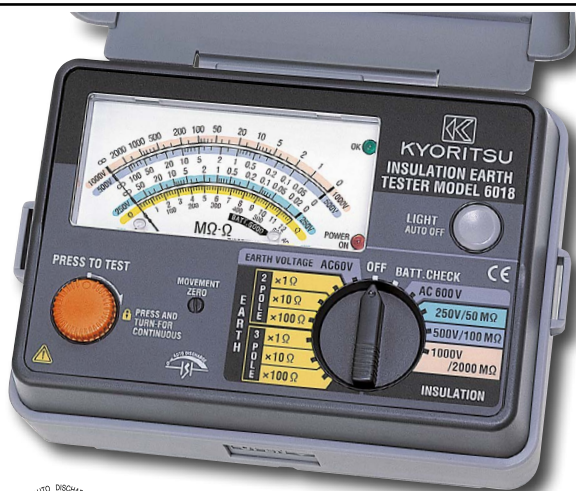

CE



3 in 1

Insulation

250/500/1000V

ACV

600V

Earth

2/3-Pole 12/120/1200Ω

	6018
Insulation testing	
Test voltage	250V/50MΩ 500V/100MΩ 1000V/2000MΩ
Accuracy	±5%rdg
Earth resistance	
Simplified precision measurement	12/120/1200Ω
Accuracy	±3% of full scale value
AC voltage	
0 - 600V AC	±3% of full scale value
Earth voltage	
0 - 60V AC	±3% of full scale value
General	
Applicable Standards	IEC 61010-1 CAT III 600V pollution degree 2 IEC 61010-2-034, IEC 61010-031, IEC 61557
Power source	R6(AA) × 8
Dimension	130(L) × 183(W) × 100(D)mm
Weight	Approx. 1000g (including batteries)
Accessories	7103A(Test leads with remote control switch) 7161A(Flat test prod[black]) 7131B(Safety alligator clips [black]) 8017(Extension prod long) 9092(Cord case) 9121(Shoulder strap) R6(AA) × 8 Instruction manual
Optional Accessories	7095A(Earth resistance test leads) 7150A(Test leads with remote control switch set) 7245A(Precision measurement cord set) 8016(Hook type prod)

PV INSULATION EARTH TESTER

KEW 6024PV



- Accurate measuring of Insulation resistance even if the PhotoVoltaic (PV) arrays are generating power
- No need to short circuit the PV arrays or test at night to measure the Insulation resistance
- Earth resistance measurements with Voltamperometric method at 3 and 2 pole
- Waterproof design, ideally suited to work in bad weather condition
- Memory function up to 1000 data
- Luminescence buttons and large Backlight display
- Elapsed time, after starting a measurement, is displayed with the measured values
- Compact and light weight
- Test probe with a remote control switch is supplied as standard accessory
- Auto-discharge with voltage display
- USB adapter for data transfer to pc and software for analysis are supplied



PV Insulation
500/1000V

Insulation
250/500/1000V

Earth
20/200/2000Ω

Volts
AC 600V/DC 1000V

- Indication of test duration facilitates insulation integrity check with one-minute readings.



PV INSULATION EARTH TESTER

6024PV					
Insulation resistance	PV Insulation*			Insulation	
Test voltage	500V	1000V	250V	500V	1000V
Range(Auto-ranging)	20.00/200.0/2000MΩ			20.00/200.0/2000MΩ	
Measuring range	0.00 - 1.50MΩ 200.1 - 2000MΩ	1.51 - 200.0MΩ	0.00 - 1.50MΩ 1001 - 2000MΩ	1.51 - 1000MΩ	-
Accuracy	±5%rdg±6dgt	±1.5%rdg±5dgt	±5%rdg±6dgt	±1.5%rdg±5dgt	
Rated current	-			1.0 - 1.2mA	
First effective measuring range				0.25MΩ	0.5MΩ
Mid-scale value				1.51 - 100.0MΩ	1.51 - 200.0MΩ
Accuracy				50MΩ	1.51 - 1000MΩ
Second effective measuring range				±1.5%rdg±5dgt	
Accuracy				1.20 - 1.50MΩ	1.20 - 1.50MΩ
Open circuit voltage	1 - 1.2times		100.1 - 2000MΩ	200.1 - 2000MΩ	1001 - 2000MΩ
Short circuit current	1.5mA or less		±5.0%rdg±6dgt		
Earth resistance					
Measuring range(Auto-ranging)	20.00/200.0/2000Ω				
Accuracy	±3.0%rdg±0.1Ω (20Ω range) ±3.0%rdg±3dgt (200/2000Ω range)				
Voltage measurement					
Measuring range	AC 5 - 600V (45 - 65Hz) DC ±5 - 1000V				
Accuracy	±1.0%rdg±4dgt				
General					
Applicable Standards	IEC 61010-1 CAT IV 300V / CAT III 600V Pollution degree 2 IEC 61010-2-030, IEC 61010-2-034, IEC 61010-031, IEC 60529(IP54), IEC 61557-1,2,5,10, IEC 61326-1,2-2				
Power source	LR6(AA)(1.5V) × 6				
Dimension	84(L) × 184(W) × 133(D)mm				
Weight	Approx. 900g (including batteries)				
Accessories	7196B(Test leads with remote control switch), 7244A(Test lead with alligator clip), 8017(Extension prod long), 8072(CAT II Standard prod) 8212-USB(USB adapter with "KEW Report(Software)"), 9155(Shoulder strap), 9156A(Soft case), LR6(AA) × 6, Instruction manual				
Optional Accessories	7243A(L-shaped probe), 7245A(Precision measurement cord set), 8016(Hook type prod)				

*6024PV supports PV systems up to 1000V.

PV INSULATION EARTH TESTER

Accurate measurement while PV arrays generating power

With conventional insulation testers:

The PV arrays need to be short-circuited. A breaker is required and risk of arc hazard exists.

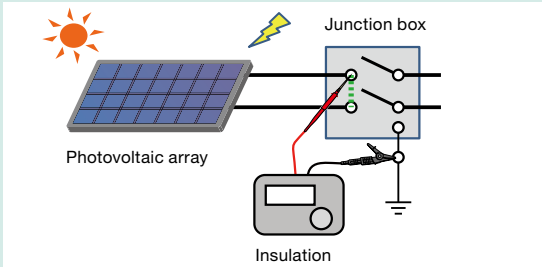

If the PV arrays are not short-circuited, low-risk, but not accurate.

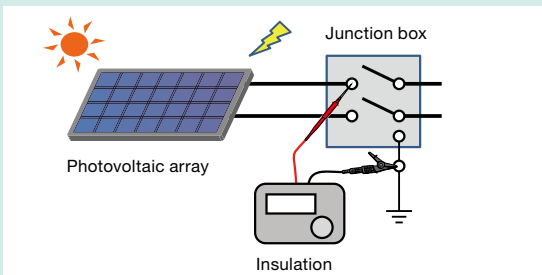

KEW 6024PV makes safe & accurate insulation resistance measurement possible!

- Increase your efficiency at work: no need waiting for the dark or compromising the accuracy of measurement.
- Safe: no need to short circuit the PV arrays.

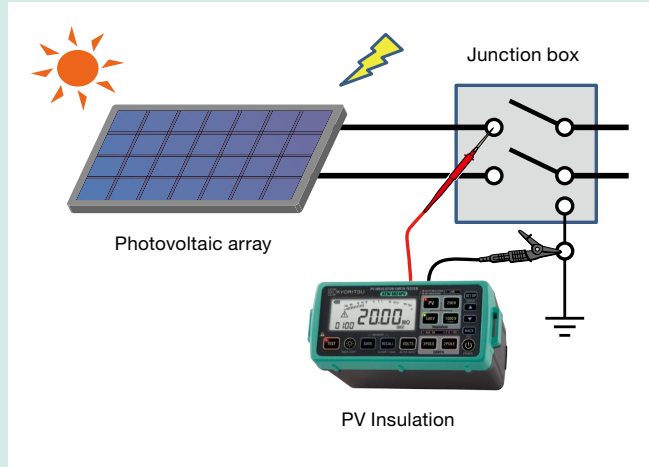

Accurate and quick measurement, unaffected by large static capacitance to earth.

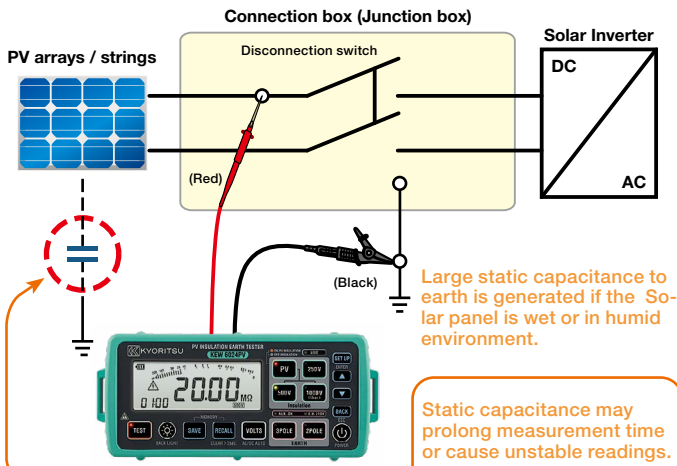

Analyzing and processing the recorded data with a PC.

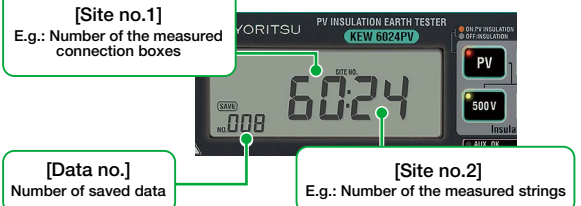

Can measure under the bad weather condition.

Accessories

MODEL 7196B
Test leads with remote control switch

MODEL 7244A
Test lead with alligator clip

MODEL 9156A
Soft Case

MODEL 8017
Extension prod long

MODEL 8072
CAT II Standard prod

MODEL 8212-USB
USB adapter with "KEW Report (Software)"

Optional Accessories

MODEL 7243A
L-shaped probe

MODEL 7245A
Precision measurement cord set

MODEL 8016
Hook type prod

MULTI FUNCTION TESTERS

Video



KEW 6516/6516BT

6516BT
Bluetooth



12 in 1

Insulation 100/250/500/1000V	Loop 2/20/200/2000Ω	RCD 10/30/100/300/500/1000mA
PSC 2000A/20kA	PFC 2000A/20kA 2000A/50kA	Earth 20/200/2000Ω
ACV 300/600V	Continuity 20/200/2000Ω	Phase rotation
Frequency	SPD(Varistor)	PAT



photo : 6516BT

MULTI FUNCTION TESTERS

- Insulation**
 - 4 ranges available for insulation resistance test(100/250/500/1000V) Automatic discharge of circuit capacitance
 - Polarization Index(PI) and Dielectric Absorption Ratio (DAR)
- Loop**
 - High test current range of 2Ω with 0.001Ω resolution
 - Zs Limit compares the values required by Electrical Installations Standard with measured results
- RCD**
 - Type AC, A, F, B(General & Selective), EV (Electric Vehicle) and Variable RCDs
 - Single and Auto test, Ramp test and Contact voltage
- Earth**
 - Earth resistance test 2 and 3 wires with all accessories included
- ACV**
 - TRMS Voltage measurements 2-600V, Mains Frequency
- Continuity**
 - Continuity test at 200mA or 15mA with selectable buzzer for fast judgment
- Phase rotation**
 - On 3-phase lines with clear indication of the sequence on the display
- SPD (Varistor)**
 - Surge Protective Device test, for SPD that uses varistor
- PAT**
 - Portable Appliance Tester function, for Insulation and Continuity
- Display**
 - Color LCD 3.5 inches dot matrix
- ATT**
 - Anti-Trip Technology (with 2 & 3 wire) for no trip LOOP L-PE testing on all RCDs
 - With 2 wire only, very useful in case of no Neutral (e.g. 3-phase motor lines)
- HELP**
 - Display shows how to connect the instrument according to the function selected
- Memory**
 - Save and display up to 1000 data
- Bluetooth**
 - Communication by "KEW CONNECT" (6516BT only)
- Safety**
 - IEC 61010-1 CAT IV 300V / CAT III 600V, IEC 61557-1,2,3,4,5,6,7,10

Accessories



Mains test lead



MODEL 7281
Test leads with remote control switch



MODEL 7246
Distribution board test leads



MODEL 7228A
Earth resistance test leads



MODEL 8041
Auxiliary earth spikes (2spikes/1set)



MODEL 8212-USB
MODEL 8212-USB with PC Software "KEW Report" (Standard accessory for KEW 6516, optional accessory for KEW 6516BT)



MODEL 9151
Shoulder strap

MODEL 9199
Shoulder pad



MODEL 9084
Soft case



MODEL 9142
Carrying case

MULTI FUNCTION TESTERS

6516/6516BT

Insulation resistance						SPD(Varistor)	
Test voltage	100V	250V	500V	1000V		Max.1000V	
Measuring ranges	2.00/20.00/200.0MΩ (Auto-ranging)		20.00/200.0/1000MΩ (Auto-ranging)	20.00/200.0/2000MΩ (Auto-ranging)		0-1049V(goes up by 1V)	
Accuracy	±2%rdg±6dgt (2.000/20.00MΩ) ±5%rdg±6dgt (200.0MΩ)		±2%rdg±6dgt (20.00/200.0MΩ) ±5%rdg±6dgt (1000MΩ)	±2%rdg±6dgt (20.00/200.0MΩ) ±5%rdg±6dgt (2000MΩ)		±5%rdg±5dgt	
Rated current	1.0-1.2mA @0.1MΩ	1.0-1.2mA @0.25MΩ	1.0-1.2mA @0.5MΩ	1.0-1.2mA @1MΩ		-	
Output short circuit current	1.5mA max					-	
Loop impedance							
Function	LOOP ATT L-PE/L-N(3wire)		L-PE(2wire)	LOOP HIGH L-PE(0.01ΩRes)		L-N/L-L	
Rated voltage	100-260V(50/60Hz)		48-260V(50/60Hz)	48-260V(50/60Hz)		48-500V(50/60Hz)	
Impedance range	20.00/200.0/2000Ω (Auto-ranging)		20.00/200.0/2000Ω (Auto-ranging)	20.00/200.0/2000Ω (Auto-ranging)		2.000Ω	
Accuracy	±3%rdg±6dgt		±3%rdg±10dgt	±3%rdg±4dgt		±3%rdg±4dgt	
Nominal test current at 0Ω external loop: Magnitude/Duration at 230V	L-N:6A/60ms N-PE:10mA		L-PE:15mA	200Ω:6A/20ms 200Ω:0.5A/20ms 2000Ω:15mA/500ms		25A/20ms 6A/20ms	
PSC/PFC							
Range	2000A/20kA(PSC/PFC)	2000A/20kA(PFC)	2000A/20kA(PFC)	2000A/50kA(PFC)	2000A/20kA(PSC)		
Accuracy	PSC/PFC accuracy is derived from measured loop impedance specification and measured voltage specification						
RCD							
Rated voltage	100-260V(50/60Hz)						
Function	x1/2, x1, x5, Ramp, Auto, Uc 10/30/100/300/500/1000mA/variable						
RCD type	AC(G/S)		A(G/S)	F(G/S)	B(G/S)		
Trip current setting	x1/2, x1, Uc	10/30/100/300/500/1000mA(G) 10/30/100/300/500(S)	10/30/100/300/500mA	10/30/100/300/500mA	10/30/100/300mA	6mA (x1 only)	
	x5	10/30/100mA	10/30/100mA	10/30/100mA	10/30mA	-	
	Ramp	10/30/100/300/500mA	10/30/100/300/500mA	10/30/100/300/500mA	10/30/100/300mA	6mA	
Accuracy	Trip current	x1/2	-8 - -2%	-10 - 0%	-10 - 0%	-	
		x1	+2 - +8%	0 - +10%	0 - +10%	0 - +10%	
		x5	+2 - +8%	0 - +10%	0 - +10%	-	
	Trip time	Ramp	-4 - +4%	-10 - +10%	-10 - +10%	-10 - +10%	-10 - +10%
		x1/2	2000ms(G/S):±1%rdg±2ms				-
x1	550ms(G):±1%rdg±2ms, 1000ms(S):±1%rdg±2ms				10.5s:±1%rdg±2ms		
x5	410ms(G/S):±1%rdg±2ms				-		
Continuity							
Range	20.00/200.0/2000Ω (Auto-ranging)						
Open circuit voltage (DC)	7-14V						
Measuring current	200mA	200mA or more (2Ω or less)					
	15mA	15mA±3mA (short-circuit)					
Accuracy	±2%rdg±8dgt						
Phase Rotation							
Rated voltage	48-600V(45-65Hz)						
Remarks	Remarks Correct phase sequence: are displayed "1.2.3" and mark Reversed phase sequence: are displayed "3.2.1" and mark						
Volts							
Range	300.0/600V(Auto-ranging)						
Measuring ranges	Volts		2-600V				
	Frequency		45-65Hz				
Accuracy	Volts		±2%rdg±4dgt				
	Frequency		±0.5%rdg±2dgt				
Earth							
Range	20.00/200.0/2000Ω(Auto-ranging)						
Accuracy	±2%rdg±0.08Ω(20.00Ω) ±2%rdg±3dgt(200.0/2000Ω)						
General							
Applicable Standards	IEC 61010-1 CAT IV 300V / CAT III 600V Pollution degree 2, IEC 61010-2-034, IEC 61557-1,2,3,4,5,6,7,10, IEC 60529(IP40), IEC 61326(EMC)						
Communication Interface	USB, Bluetooth® 5.0 *1						
Power source	LR6 × 8						
Dimension / Weight	136(L) × 235(W) × 114(D)mm / 1350g (including batteries)						
Accessories	Mains test lead*2, 7281(Test leads with remote control switch), 7246(Distribution board test lead), 7228A(Earth resistance test leads), 8041(Auxiliary earth spikes[2spikes/1set]) 9084(Soft case), 9142(Carrying case), 9151(Shoulder strap), 9199(Shoulder pad), Battery, Instruction manual, 8212-USB(USB adapter with "KEW Report(Software)" for 6516)						
Optional Accessories	8212-USB(USB adapter with "KEW Report(Software)" for 6516BT), 8259(Adapter for measurement terminal), 7272(Precision measurement cord set), 8017A(Extension prod long)						

*1 6516BT only

Some countries regulate the compliance with their Radio Law of the products equipped with Bluetooth®. Please confirm it with your distributor before purchasing our products equipped with Bluetooth®.

*2 7187A:British plug, 7218A:(EU)European SCHUKO plug, 7221A(SA) South african plug, 7222A:(AU)Australian plug

Optional Accessories

MODEL 7272

Precision measurement cord set

MODEL 7267 Cable reel for

Earth resistance tester (Red) 20m

MODEL 7268 Cable reel for

Earth resistance tester (Yellow) 10m

MODEL 7271 Earth resistance test lead (Green) 5m

MODEL 8041 Auxiliary earth spikes[2spikes/1set]

MODEL 9192 Carrying case for cord reels



MODEL 8017A
Extension prod long



MODEL 8259
Adapter for measurement terminal
[red, yellow, green/1set]

Communication interface

USB



KEW Report

Bluetooth®



KEW Smart
Advanced

Please search "KEW Smart"

Communication charge may be incurred separately to download application.

EVSE ADAPTERS

KEW **8601** **NEW** / **8602** **NEW**



photo : 8602



Dedicated adapter for EVSE(Electric Vehicle Supply Equipment) installation inspections, maintenance and troubleshooting

- EVSE tests under various simulations
- Touch pad for PE voltage check
- CP signal terminals for CP signal monitoring

*Supporting normal chargers (AC) only, not supporting fast (DC) chargers

	8601	8602
Plug	SAE J1772 / IEC 62196-2 type1	IEC 62196-2 type2
Rated voltage	AC 250V Max.	AC 250V Max.(Single-phase) AC 430V Max.(Three-phase)
Rated frequency	50/60Hz	
Rated voltage / current of mains socket	—	AC 10A/250V *8602(EU):Type E socket, 8602(UK):Type BF socket 8602(AU):Type O socket
Fuse rating	—	AC 10A/250V φ5×20mm
Operating temperature and humidity range	0 - 40°C, relative humidity 80 % or less (no condensation)	
Storage temperature and humidity range	-10 - 50°C, relative humidity 80 % or less (no condensation)	
Applicable standards	IEC 61010-1 CATII 250V IEC 61010-2-030 IEC 60529 (IP40)	IEC 61010-1 CATII 300V IEC 61010-2-030 IEC 60529 (IP40)
Altitude	2000m or less	
Cable length	Approx. 250 mm	
Dimension	Unit: 172(L) × 105(W) × 57(D)mm Plug part: 175(L) × 60(W) × 53(D)mm	
Weight	Approx. 840g	
Accessories	9202(Carrying case) Instruction manual	8930(Fuse[10A/250V]) 9202(Carrying case) Instruction manual
Optional Accessories	—	8603(TYPE1 to TYPE2 conversion adapter)

Accessories



Optional Accessories



EVSE ADAPTERS

Measuring terminals

Various tests and confirmations are possible by connecting measuring instruments.

Type1

KEW 8601

Type2

KEW 8602

CP signal output terminals

Terminals for measuring CP signals with oscilloscope, etc.

PE PRE-TEST

Touch pad and LED to test for dangerous voltages present on the PE.

Error simulation

CP Error simulation button
The case of an earth fault in the CP line can be simulated. While this button is pressed, the EVSE output is stopped.

PE Error simulation button
This button can be used to simulate the case of a broken earth wire. While this button is pressed, the EVSE output is stopped.

Mains socket (8602 only)

Load current tests up to 10A can be carried out with this socket.
*Sockets are available in EU, UK and AU types.

PP(Proximity Pilot) state selector (8602 only)

This selector can be used to simulate the rated capacity of the cable in the Untethered EVSE.

Resistance between PP and PE depending on cable current rating

Cable current rating	Resistance between PP and PE
No cable	Open
13A	1.5kΩ
20A	680Ω
32A	220Ω
63A	100Ω

CP(Control Pilot) state selector

By operating this selector, the connection state of the vehicle can be simulated.

A: Not connected

B: Connected

C: Ready to charge

D: Ready to charge (Ventilation required)

EVSE ADAPTERS

Tests conducted under dead-line conditions (CP STATE A)

Insulation test (for cable)

By connecting the test leads to the adapter terminal, the insulation resistance of cables can be measured for both single phase and three phase EVSE.

*Insulation measurement between wires other than PE is not possible.

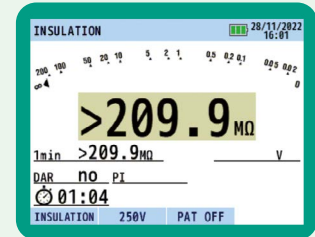

Earth Continuity test (200mA)

It is possible to check continuity between the PE terminal of the adapter and the outer metal part or the earth of the electrical circuit.

Earth test (3-wire & 2-wire)

The resistance of the earth to which the EVSE is connected can be measured.

Tests conducted under live line conditions (CP STATE C, D)

Voltage

Voltage/frequency between each terminal can be measured.

Phase rotation

Phase rotation of three phase power supply can be measured.

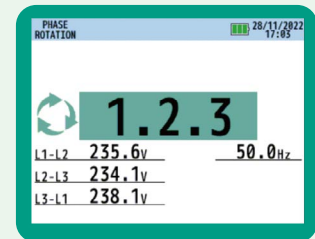

Loop Impedance (Loop ATT function)

Loop impedance between Line-Earth can be measured.

Typical measuring instruments are designed to make Loop impedance measurements on circuits where RCDs are installed, at currents that do not trip the RCD, which is rated at 30mA.

However, the 6mA DC RCDs built into the EVSE often trip even at this current, so the KEW 6516/6516BT has a dedicated EVSE range that measures Loop impedance at even lower currents.

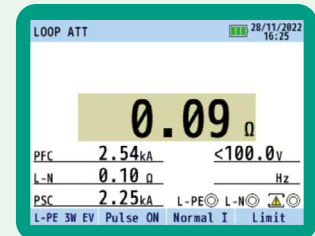

RCD test

IEC 60364-7-722 standard states that EVSE should have Type B, Type A or Type F RCDs, and a residual direct current detecting device (RDC-DD) complying with IEC 62955.

KEW 6516/6516BT can test above RCDs: Type A, B, F and also the test on dedicated EV type RCD (30mA AC +DC 6mA), and AC type too.

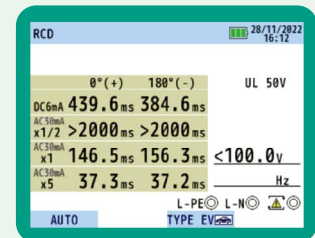

Kits

KEW 6516-EV2

KEW 6516 x1
 KEW 8602 x1

KEW 6516BT-EV2

KEW 6516BT x1
 KEW 8602 x1



POWER METERS

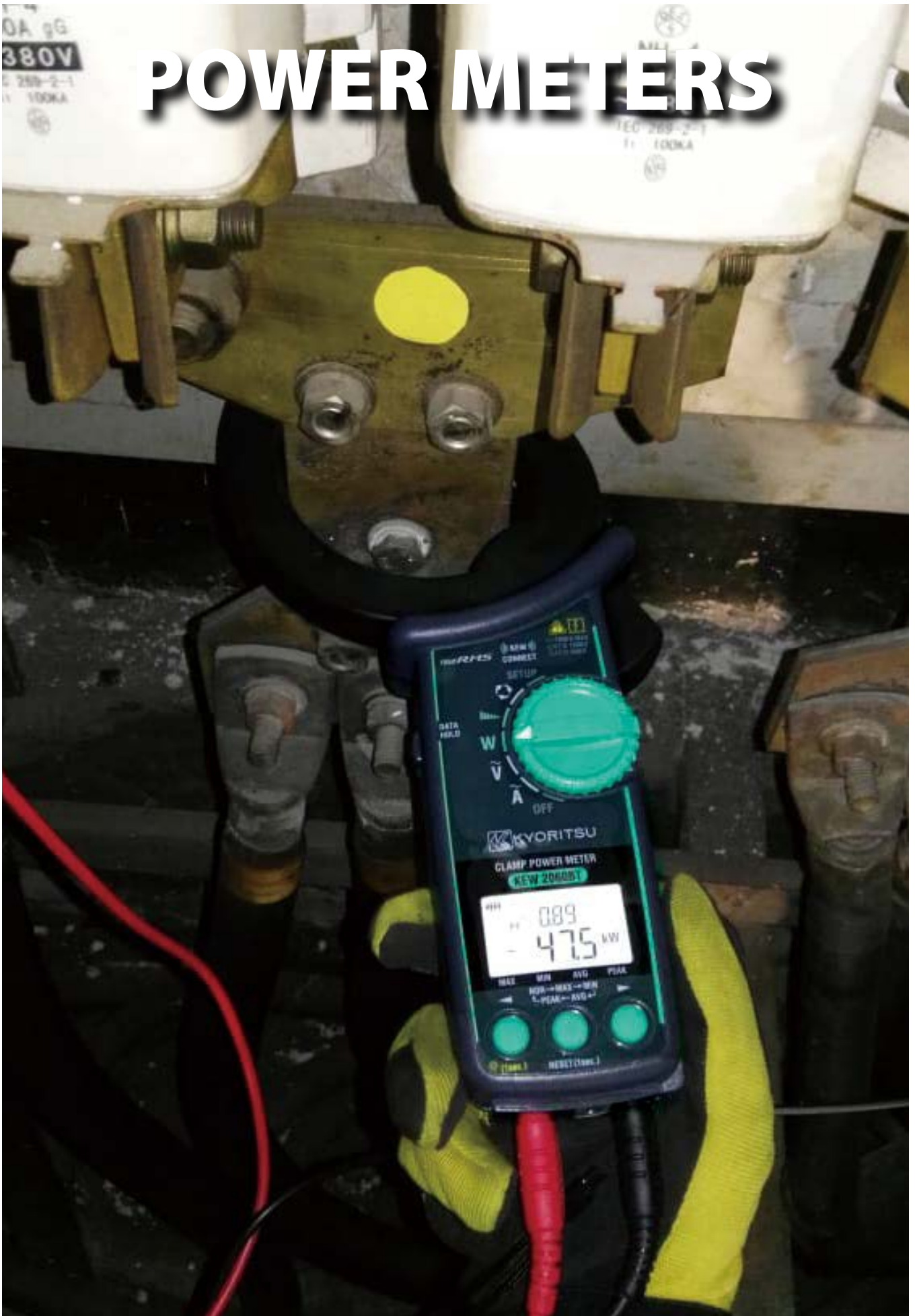

POWER METERS

CLAMP POWER METERS

KEW 2060BT/2062/2062BT



photo : 2060BT



photo : 2062



photo : 2062BT

TRUE RMS
CAT IV 600V
CAT III 1000V
CAT II 1000V
075
055

W
AC V
AC A
Hz
DATA HOLD
PEAK HOLD
MAX/MIN AVG
PF
Bluetooth

- Current up to 1000A rms
- Voltage up to 1000V rms
- Harmonics up to 30th

Jaw shape with emphasis on the safety and the usability

- KEW 2060BT has a newly designed special jaw shape for using at a large busbar. Extremely large jaw with tear drop shape can clamp a large busbar with safe (Conductor size 75mm, Busbar 80mm x 30mm)
- KEW 2062 and KEW 2062BT have a tear drop shape jaw, and the size is convenient to use at a small-sized office and factory (Conductor size 55mm)

KEW CONNECT

Wireless communication with smartphone or tablet (Except for 2062)



	2060BT	2062/2062BT
Wiring connections	1P2W, 1P3W, 3P3W, 3P4W	
Measurements and parameters	Voltage, Current, Frequency, Active power, Reactive power, Apparent power, Power factor (cos θ), Phase angle, Harmonics (THD-R/THD-F), Phase rotation	
ACV		
Range	1000V	
Accuracy	±0.7%rdg±3dgt(40.0 - 70.0Hz) ±3.0%rdg±5dgt(70.1Hz - 1kHz)	
Crest factor	1.7 or less	
ACA		
Range	40.00/400.0/1000A (3 range auto)	
Accuracy	±1.0%rdg±3dgt (40.0 - 70.0Hz) ±2.0%rdg±5dgt (70.1Hz - 1kHz)	
Crest factor	3 or less on 40.00/400.0A range, 3 or less 1500A peak on 1000A range	
Frequency		
Display range	40.0-999.9Hz	
Accuracy	±0.3%rdg±3dgt	
Active power		
Range	40.00/400.0/1000kW	
Accuracy	±1.7%rdg±5dgt (PF1, sine wave, 45-65Hz)	
Apparent power		
Range	40.00/400.0/1000kVA	
Accuracy	±1dgt against each calculated value Sum: add errors of each channel, 3P3W: ±2dgt, 3P4W: ±3dgt	
Reactive power		
Range	40.00/400.0/1000kVar	
Accuracy	±1dgt against each calculated value Sum: add errors of each channel, 3P3W: ±2dgt, 3P4W: ±3dgt	
Power factor		
Display range	-1.000 - 0.000 - +1.000	
Accuracy	±1dgt against each calculated value Sum: add errors of each channel, 3P3W: ±2dgt, 3P4W: ±3dgt	
Phase angle (1P2W only)		
Display range	-180.0 - 0.0 - +179.9	
Accuracy	Within ±3.0°	
Harmonics RMS (Content rate)		
Analysis order	1st - 30th order	
Accuracy	±5.0%rdg±10dgt (1 - 10th) ±10%rdg±10dgt (11 - 20th) ±20%rdg±10dgt (21 - 30th)	
Total harmonics THD-R/THD-F		
Display range	0.0 - 100.0%	
Accuracy	±1 against the calculated results of each measured value.	
Phase rotation	ACV 80 - 1100V (45 - 65Hz)	
Other functions	MAX/MIN/AVG/PEAK, Data hold, Bluetooth® (Except for 2062), Backlight, Auto power off	
General		
Communication interface	Bluetooth® 5.0*	
Power source	LR6(AA)(1.5V) × 2	
Continuous measuring time	Approx. 58 hours	
Conductor size	φ75mm max. (busbar 80×30mm)	φ55mm max.
Dimension / Weight	283(L)×143(W)×50(D)mm / Approx. 590g (including batteries)	247(L)×105(W)×50(D)mm / Approx. 490g (including batteries)
Applicable Standards	IEC 61010-1, IEC 61010-2-032, IEC 61326-1, 2-2 ClassB CAT IV 600V / CAT III 1000V Pollution degree 2 CAT IV 300V / CAT III 600V / CAT II 1000V Pollution degree 2	
Accessories	7290 (Voltage test lead set), 9198 (Carrying case), LR6(AA)×2, Instruction Manual	

* Some countries regulate the compliance with their Radio Law of the products equipped with Bluetooth®. Please confirm it with your distributor before purchasing our products equipped with Bluetooth®. Bluetooth® is a trademark or registered trademark of Bluetooth SIG, Inc. Android™ is a trademark or registered trademark of Google Inc. iOS is a trademark or registered trademark of Cisco Technology, Inc. in the United States and other countries.

Power measurement on any wiring system is possible.

KEW 2060BT, KEW 2062 and KEW 2062BT can perform 1P2W measurement and balance and unbalance measurements of 3P3W / 3P4W. The double display can simultaneously show many parameters like W & PF, W & deg, W & VA, W & Var, V & A, etc.

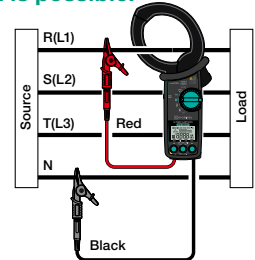

* E.g.: 3P4W(Balance)

Use the application KEW Power* to improve work efficiency (Except for 2062)



Display image

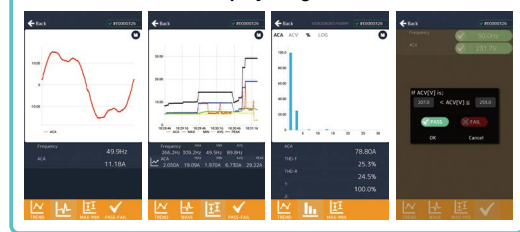

Download and install our special application "KEW Power*" in your smartphone or tablet device for logging the measured values. Remote monitoring of voltage, current, power, trend graph of harmonics, and waveform is possible with "KEW Power*"; this is helpful for simple Power Quality check. Measured values can be saved in your smartphone or tablet device in csv format: the data is editable in excel format.

Accessories





KEW 6305

RMS USB Bluetooth External Power Supply



CE

- Comprehensive real-time monitoring, recording and analysis of single and 3-phase systems
- Voltage, Current, Power Factor and Frequency measurements
- Power analysis (Active, Apparent and Reactive power)
- Energy analysis (Active, Apparent and Reactive energy)
- Active power accuracy: $\pm 0.3\%rdg \pm 0.2\%f.s.$
- Automatic wiring check function to prevent incorrect connections
- Large memory capability (2GB) using built-in SD card Interface
- Recording interval can be set between 1 second and 1 hour
- Real-time and remote measurements
- Windows software for data analysis and setting via USB port or Bluetooth®
- Synchronous measurements between two units of KEW 6305
- Wide selection of clamp sensors allow measurements from 0.1 to 3000A
- Automatic recognition of connected sensor type
- Double power supply system via AC line and batteries

As easy as 1 → 2 → 3!

Starting from OFF position and rotating the Rotary switch clockwise, KEW 6305 is ready to use in 3 simple steps

1. SET UP

Rotate the Rotary switch to SET UP. All the instrument settings can be easily selected by using instrument buttons. All the settings can also be selected by connecting KEW 6305 to a PC via USB or Bluetooth®.

2. WIRING CHECK

Rotate the Rotary switch to WIRING CHECK. The Automatic Wiring check function will prevent incorrect connections, check the connections and display the results on the LCD. Error messages appear on display to indicate wrong orientation of Clamp sensors or incorrect connections.

Everything is OK



Shows "Good"

Error is found



Shows "Err" (Error) e.g.: Err PH A
→ Current phase (orientation of sensor) may be incorrect.

3. W/Wh/DEMAND Measurements

Rotate the Rotary switch to W/Wh/DEMAND. The instrument can perform Instantaneous, Integration and DEMAND measurements. Press START / STOP button to start / stop recording.

	6305
Wiring connections	1P2W, 1P3W, 3P3W, 3P3W3A, 3P4W
Measurements	Voltage, Current, Frequency, Active power
Parameters	Apparent power, Reactive power, Active energy, Apparent energy, Reactive energy, Power factor (cos θ), Neutral current
Voltage range[RMS]	150.0/300.0/600.0V
Voltage accuracy	$\pm 0.2\%rdg \pm 0.2\%f.s.$ (sine wave, 45 - 65Hz)
Current range[RMS]	10.00/50.00/100.0/250.0/500.0A/Auto (with clamp sensor MODEL 8125)
Current accuracy	$\pm 0.2\%rdg \pm 0.2\%f.s.$ + Accuracy of Clamp sensor (sine wave, 45 - 65Hz) +1%f.s. at the lowest range.
Effective input range	10 - 110% of rating range
Display range	5 - 130% of each range (Voltage) 1 - 130% of each range (Current)
Crest factor	Voltage : 2.5 or less, Current : 3.0 or less (max. 1.4Vpeak)
Active power accuracy	$\pm 0.3\%rdg \pm 0.2\%f.s.$ + Accuracy of Clamp sensor +1%f.s. when the lowest current ranges is selected.
Effect of power factor	Active power: $\pm 1.0\%rdg \cos \theta = \pm 0.5$ (PF=1)
Frequency meter range	40.0 - 70.0Hz
Frequency meter accuracy	$\pm 3dgt$
Accuracy precondition	PF=1, Sine wave, 45 - 65Hz, 23°C $\pm 5^\circ C$
Display update period	1 second
Operating temperature and humidity range	0 - +50°C, relative humidity 85% or less(no condensation)
Storage temperature and humidity range	-20 - +60°C, relative humidity 85% or less(no condensation)
Communication interface	USB, Bluetooth® 5.0
PC card interface	SD card (2GB)
Safety standard	IEC 61010-1 CAT III 600V
Power source (AC Line)	AC100 - 240V $\pm 10\%$ (45 - 65Hz)
Power source (DC battery)	LR6 or Ni-MH(HR-15-51) $\times 6$ (Battery charger not included), Battery life approx. 15h (LR6)
Power consumption	10VA (max.)
Dimension	175(L) \times 120(W) \times 65(D)mm
Weight	Approx. 800g (including batteries)
Accessories	7141B (Voltage test lead set), 7148 (USB cable) 7170(Power cord[E.U]) or 7240(Power cord[UK]), 9125(Carrying case) 8326-02 (SD card [2GB]), KEW Windows (PC Software) Battery(LR6) $\times 6$, Quick manual
Optional Accessories	8124, 8125, 8126, 8127, 8128(Load current Clamp Sensor) 8130, 8133, 8135(Flexible Clamp Sensor) 8312(Power supply adapter), 9132(Carrying case with magnet)

*Some countries regulate the compliance with their Radio Law of the products equipped with Bluetooth®. Please confirm it with your distributor before purchasing our products equipped with Bluetooth®.

POWER METERS

Bluetooth® communication with Android application

Free Android software "KEW Smart 6305" is available on download site



*communication charges may be incurred separately to download application

Real-time and remote measurements using Android application

Measurement can be displayed in graphic or numeric forms on Android devices in real-time via Bluetooth® communication.

Remote checking of measurements is possible without accessing KEW 6305.



Max communication distance: 10m

Android device

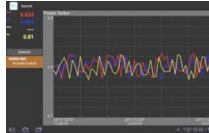

Real-time display

Bluetooth® is a registered trademark of the Bluetooth SIG, Inc. Android is a registered trademark of the Google Inc.

Windows software

Automatic creation of graph and list from recorded data.

Centralized management of setting and recorded data acquired from multiple devices. Data can be expressed in crude oil and CO₂ equivalent values in the report.

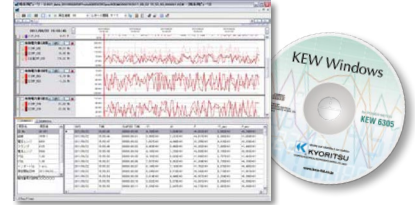

System requirements

OS: Windows® 11/10
 Display: XGA(Resolution 1024 × 768 dots) or more
 Required HDD space: 1Gbyte or more
 Others: With CD-ROM drive and USB port
 .NET Framework (4.6.1 or later)

* Windows® is a registered trademark of Microsoft in the United States.

Optional Accessories

Load current clamp sensors

MODEL 8128



CE MAX 50A Ø24

MODEL 8127



CE MAX 100A Ø24

MODEL 8126



CE MAX 200A Ø40

MODEL 8125



CE MAX 500A Ø40

MODEL 8124



CE MAX 1000A Ø68

Load current flexible clamp sensors

KEW 8135



CE MAX 50A Ø75

KEW 8130



CE MAX 1000A Ø110

KEW 8133



CE MAX 3000A Ø170

Power supply adapter

MODEL 8312

For taking single phase supply (100-240V) from the test leads to power the instrument (Fuse: 8923)



Carrying case with magnet

MODEL 9132

For mounting inside metal distribution boards



SD card Interface

SD cards up to 2GB can be used.

Max amount of data (reference)

Data saved on:	SD card	Internal memory
Capacity	2GB	3MB
Instantaneous measurement	6,670,000	10,000
Integration / demand measurement interval	1 sec.	17 days
	1 min.	992 days
	30 min.	33 hours
Max number of files	511	4

*in case the SD card is empty

Selection Guide of Power Meters					
	Clamp Power Meter			Power Meter	Power Quality Analyzer
	2060BT	2062	2062BT	6305	6315
Appearance					
Voltage [V]	✓	✓	✓	✓	✓
Current [A]	✓	✓	✓	✓	✓
Power [W]	✓	✓	✓	✓	✓
Frequency [Hz]	✓	✓	✓	✓	✓
Energy [Wh]	–	–	–	✓	✓
Harmonics	✓	✓	✓	–	✓
Power Quality	Swell	–	–	–	✓
	Dip	–	–	–	✓
	Interruption	–	–	–	✓
	Transients	–	–	–	✓
Inrush Current	–	–	–	–	✓
Conductor size	φ75mm	φ55mm	φ55mm	–	–
Memory	–	–	–	SD card	SD card
Number of Input Channel	4ch (V3, A1)	4ch (V3, A1)	4ch (V3, A1)	6ch (V3, A3)	7ch (V3, A4)
Communication interface	Bluetooth®	–	Bluetooth®	USB, Bluetooth®	USB, Bluetooth®

Kits



KEW 6305-01

KEW 6305 × 1
 MODEL 8125 × 3
 Carrying case : MODEL 9125



KEW 6305-03

KEW 6305 × 1
 KEW 8130 × 3
 Carrying case : MODEL 9135

KEW 6305-05

KEW 6305 × 1
 KEW 8133 × 3
 Carrying case : MODEL 9135

POWER QUALITY ANALYZER

KEW **6315**



True RMS USB Bluetooth External Power Supply



- Simultaneous Power & Power quality measurements
Power/Harmonics/Waveform/Power quality are recorded at all CHs (Voltage:3ch,Current 4ch)
- Helpful support functions
Quick Start Guide,Wiring check and Sensor detection for easy and reliable measurement
- Measurement with high accuracy
Guaranteed accuracy: $\pm 0.3\%rdg(energy)$,
 $\pm 0.2\%rdg(voltage/current)$
Complies with the International Standard
IEC 61000-4-30 Class S and the European Standard EN50160
- Energy consumption check on site
Trend and demand graphs for easy recognition
- TFT color display with high resolution
- IEC 61010-1 CAT IV 300V / CAT III 600V / CAT II 1000V

		6315
Wiring connections		1P2W, 1P3W, 3P3W, 3P4W
Measurements and parameters		Voltage, Current, Frequency, Active power, Reactive power, Apparent power, Active energy, Reactive energy, Apparent energy, Power factor (cos ϕ), Neutral current, Transients/Demand, Harmonics, Quality(Swell/Dip/Interruption, voltage, Inrush current, Unbalance rate), Phase advance condenser, IEC Flicker
Other functions		Digital output function, External communication function,Scaling function
Voltage [RMS]	Range	600.0/1000V
	Accuracy	600.0V Range : (sine wave 40 - 70Hz) 10% - 150% against 100V or more of nominal V : Nominal V $\pm 0.5\%$ Out of above range : $\pm 0.2\%rdg\pm 0.2\%f.s.$ 1000V Range : $\pm 0.2\%rdg\pm 0.2\%f.s.$ (sine wave 40 - 70Hz)
	Allowable input	1 - 120% of each range (rms). 200% of each range (peak)
	Display range	0.15 - 130% of each range
	Crest factor	3 or less
	Sampling speed	24 μ s
Current [RMS]	Range	8128/8135(50A type): 5000mA/50.00A/AUTO 8127(100A type): 10.00/100.0A/AUTO 8126(200A type): 20.00/200.0A/AUTO 8125(500A type): 50.00/500.0A/AUTO 8124/8130(1000A type): 100.0/1000A/AUTO 8146/8147/8148(10A type): 1000mA/10.00A/AUTO 8133(3000A type): 300.0/3000A/AUTO
	Accuracy	$\pm 0.2\%rdg\pm 0.2\%f.s.$ +accuracy of clamp sensor (sine wave, 40 - 70Hz)
	Allowable input	1 - 110% of each range (rms). 200% of each range (peak)
	Display range	0.15 - 130% of each range
	Crest factor	3 or less
Active power	Accuracy	$\pm 0.3\%rdg\pm 0.2\%f.s.$ + accuracy of clamp sensor (power factor 1, sine wave, 40 - 70Hz)
	Influence of power factor	$\pm 1.0\%rdg$ (reading at power factor 0.5 against power factor 1)
Frequency meter range		40 - 70Hz
Power source (AC Line)		AC100 - 240V/50 - 60Hz/7VA max
Power source (DC battery)		LR6 or Ni-MH(HR15-51) \times 6 Battery life approx. 3h (LR6,Backlight OFF)
Memory card		SD card (2GB)
Communication interface		USB, Bluetooth [®] 5.0*
Display		320 \times 240(RGB)Pixel, 3.5inch color TFT display
Temperature and humidity range		23 \pm 5 $^{\circ}$ C, relative humidity 85% or less(no condensation)
Operating temperature and humidity range		0 - 45 $^{\circ}$ C, relative humidity 85% or less(no condensation)
Storage temperature and humidity range		-20 - 60 $^{\circ}$ C, relative humidity 85% or less(no condensation)
Applicable Standards		IEC 61010-1 CAT IV 300V / CAT III 600V / CAT II 1000V Pollution degree 2 IEC 61010-2-030, IEC 61010-031, IEC 61326, EN 50160 IEC 61000-4-30 Class S, IEC 61000-4-15, IEC 61000-4-7
Dimension / Weight		175(L) \times 120(W) \times 68(D)mm / Approx. 900g
Accessories		7141B(Voltage test lead set), 7170(Power cord(EU)) or 7240(Power cord(UK)) 7219(USB cable), 8326-02(SD card (2GB)), 9125(Carrying case) Input terminal plate \times 6, KEW Windows for KEW6315(software) Quick manual, LR6(AA) \times 6

*Some countries regulate the compliance with their Radio Law of the products equipped with Bluetooth[®]. Please confirm it with your distributor before purchasing our products equipped with Bluetooth[®].

Simultaneous Power & Power quality measurements



Power & Energy

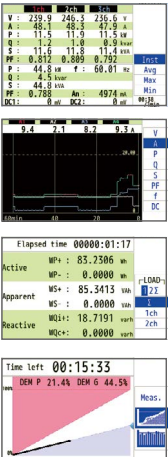

Instantaneous value

- Measures instantaneous / average / min / max for voltage, current, active / reactive / apparent power, PE(cos ϕ) and line frequency all on one screen.
- Trend of all main parameters and customized Zoom functions.

Integration value

- The display will list the active / reactive / apparent energy in total and for each phase consumed (or generated in case of co-generation like solar panels, etc).

Demand

- To support demand control, present energy usage and estimated value are displayed on a graph while recording max demand value and the occurred time.



Vector

- Can display voltage and current by vector per Ch.



Waveform

- Displays voltage and current on each Ch by waveform.



Harmonics Analysis

- Graphic display of harmonic components up to 50th order for voltage, current and power.



Event

- Measures voltage swells / dips / interruptions / transients and inrush currents that may indicate a weak power distribution system. Such phenomena may damage or reset devices. All necessary data is displayed by pressing one key.

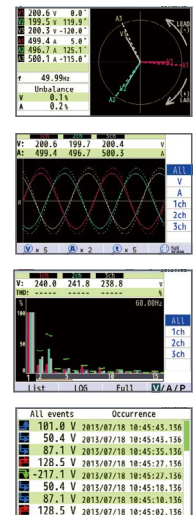

POWER QUALITY ANALYZER

Quick Start Guide

One-Touch START/STOP Key for Quick Start Guide providing easy setup guides.

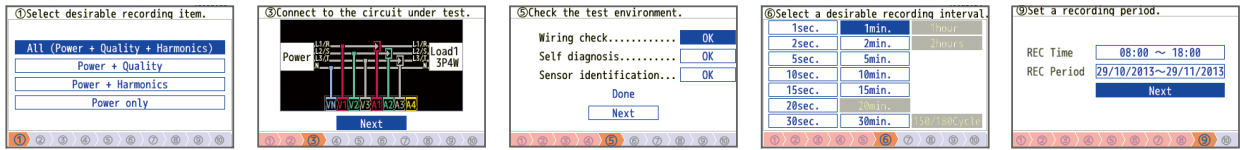

Guide start

Connect to the circuit

Wiring check

Select interval

Set recording time

Start recording

Windows software for data analysis and setting via USB port

- Automatic creation of graph and list from recorded data.
- Centralized management of setting and recorded data acquired from multiple devices.
- Data can be expressed in crude oil and CO₂ equivalent values in the report.
- EN 50160 report can be generated after survey.

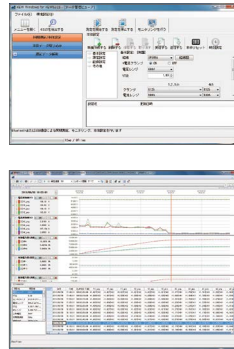

System requirements

OS: Windows® 11/10
 Display: XGA(Resolution 1024 x 768 dots) or more
 Required HDD space: 1Gbyte or more
 Others: With CD-ROM drive and USB port
 .NET Framework (4.6.1 or later)
 ※Windows® is registered trademark of Microsoft in the United States.

Real-time and remote measurements

- Measurements can be graphically displayed on Android devices or PC in real-time via Bluetooth® communication.



※Bluetooth® is a registered trademark of the Bluetooth SIG, Inc.
 Android™ is a registered trademark of the Google Inc.

Optional Accessories

Load current clamp sensors



Leakage & Load current clamp sensors



※8146/8147/8148 can measure up to 10A for use in KEW 6315

Load current flexible clamp sensors



Distribution board door can be closed during measurement?

KEW 6315 facilitates safe testing thanks to its extreme compact design and with two attractive optional accessories: a carrying case with magnet (9132) for attaching it to the sides of metal enclosures and a power supply adapter (8312) which takes the power for the instrument from the supply being measured.



SD card Interface

SD cards up to 2GB can be used

Possible recording time
 When the 2GB of SD is used:

8326-02



Interval	REC item	
	Power	+Harmonics
1 sec.	13 days	3 days
1 min.	1 year or more	3 months
30 min.	10 year or more	7 year or more

Data of power quality events are not considered to estimate the possible recording time. The max possible time will be shortened by recording such events.

Kits



KEW 6315-01
 KEW 6315 × 1
 MODEL 8125(500A) × 3
 Carrying case : MODEL 9125



photo : 6315-03

KEW 6315-03
 KEW 6315 × 1
 KEW 8130(1000A) × 3
 Carrying case : MODEL 9135

KEW 6315-04
 KEW 6315 × 1
 KEW 8130(1000A) × 4
 Carrying case : MODEL 9135

KEW 6315-05
 KEW 6315 × 1
 KEW 8133(3000A) × 3
 Carrying case : MODEL 9135

LOGGERS

KEW 5010 (for Current) KEW 5020 (for Current/Voltage)



photo : 5020



3 channel inputs for the simultaneous recording of Leakage Current, Load Current and Voltage

Power Quality analysis (5020 only)

(Power Quality: Reference voltage, Swell, Dip, Short power Interruptions)

Large capacity for storing 60,000 data points

60,000 data points can be recorded when 1ch is used, and when all the three channels are used, 20,000 data points per channel can be recorded

Lowpass Filter will filter out the harmonics

(Cutoff Frequency = Approx. 160Hz)

LED blinks when the preset current / voltage value is exceeded

(Available for Trigger / Capture Recording, Power Quality Analysis modes)

CALL : Confirmation of recorded data

- The following can be displayed: number of recorded data points, (max+ min+ peak) value for each channel complete with time/date information in the Normal recording mode (Detected values (i.e. when values are outside preset limits) can be displayed in other recording modes)
- RECALL: The last 10 recorded data points including time/date can be recalled on the logger display



Selection of One-time mode or Endless mode

One-time on : →

Recording will stop when memory is used up

One-time off : ↻

Overwrite the old data, and store the latest data

Non Volatile Memory

Recorded data will be retained even if the batteries are exhausted or replaced due to the presence of a nonvolatile memory

Battery power indicator

Indicates battery voltage in 4-levels

(It is possible to use the logger for a further approx. 24 hours even after the warning symbol is flashing)

The user friendly PC software "KEW LOG Soft 2" is supplied

- Supplied with the user friendly software "KEW LOG Soft 2"
- This permits editing, analysis and graphical display of data
- The recorded data is downloadable to a PC via USB cable
- Variation of the measured voltage and current data can be confirmed simultaneously on the PC display monitor (5020 only)
- Simplified Power Integration
(The "KEW LOG Soft 2" uses current and voltage recorded to calculate the integral power consumption)
- Continuous measuring time : Approx. 10 days (Alkaline Battery)

	5010	5020
Recording mode	Normal, Trigger, Capture	Normal, Trigger, Capture, Power quality analysis
Operating system	Successive approximation(CH1 single synchronized sampling)	
Rated max. working voltage	AC9.9Vrms, 14V peak value	
Number of input channel	3ch	
Measuring method	True RMS	
RMS measuring interval	Approx. 100ms	
Sampling interval	Approx. 1.65ms/CH	
	: Normal / Trigger mode	Approx. 0.55ms (waveform: at every 1.1ms)
	: Capture mode	Approx. 0.55ms (waveform: at every 1.1ms)
	: P.Q.A mode	Approx. 0.55ms
Low battery warning	Battery mark display (in 4 levels)	
Over-range indication	"OL" mark is displayed when exceeding the measuring range	
Auto power off	Turns off the instrument automatically if there is no switch operation for about 3 min.(This function doesn't work during a recording.)	
Location for use	Indoor use, Altitude up to 2000m	
Operating temperature and humidity range	-10 - 50°C, relative humidity 85% or less (no condensation)	
Battery	LR6(AA)(1.5V) × 4 / External supply DC9V(Special AC Adapter)	
Possible measurement time	Approx. 10days (with alkaline LR6 batteries)	
Applicable Standards	IEC 61010-1 CAT III 300V Pollution degree2, IEC 61326 (EMC)	
Dimension	111(L) × 60(W) × 42(D)mm	
Weight	Approx. 265g	
Accessories	LR6(AA) × 4, 9118(Carrying case), KEW LOG Soft 2(PC software), 7148(USB cable) Instruction manual, Quick manual, Install manual, USB Notice sheet	
Optional Accessories	8146,8147,8148(Leakage & Load current clamp sensor), 8121,8122,8123,8124,8125,8126,8127,8128(Load current clamp sensor) 8130,8135(Flexible clamp sensor), 8309(Voltage sensor : 5020 only), 8320(AC adapter), 9135(Carrying case), 7185(Extension cable)	

Normal Recording Mode

(AC 50/60Hz, Sine wave, Input: 10% or more of the range at CH1)

Range	RMS Accuracy
100.0mA	±2.0%rdg±0.9%f.s. + Accuracy of sensor
Other ranges	±1.5%rdg±0.7%f.s. + Accuracy of sensor
Crest factor	2.5 or less :RMS accuracy(sine)+ 2%rdg+1%f.s.

*Max, Min and Instant Peak values in Normal Recording mode are just reference values; their accuracies aren't guaranteed.

Trigger Recording Mode

(AC 50/60Hz sine wave)

Range	Accuracy
100.0mA	±3.5%rdg±2.2%f.s. + Accuracy of sensor
Other ranges	±3.0%rdg±2.0%f.s. + Accuracy of sensor

Capture/ Power Quality Analysis Recording Mode

Range	Accuracy
100.0mA	±3.0%rdg±1.7%f.s. + Accuracy of sensor
Other ranges	±2.5%rdg±1.5%f.s. + Accuracy of sensor

LOGGERS

4 recording modes make various measurements possible



Normal recording mode

For monitoring power line status or an intermittent leakage.

- Records the variation of the current / voltage in a given interval (For monitoring the variation of the current / voltage against time).
- A choice of 15 recording intervals are available: 1 sec. to 60 min. (1,2,5,10,15,20,30 sec, 1,2,5,10,15,20,30,60 min.)
- The average of the measured value in every recording interval is recorded. The Max., Min. and Peak values (sampled crest value converted to sine RMS value) are recorded every 10 readings.

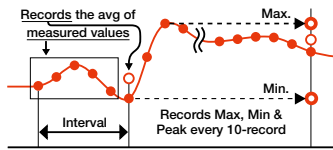

Trigger recording mode

For observing an irregular operation of an ELCB/RCD and irregular current / voltage.

- Detects the value, time and frequency of the current / voltage when the preset value is exceeded.
- When the detection level (i.e. preset value) is exceeded, 8 data points (True RMS values for approx. 0.8 sec.) and peak value are recorded before and after the preset value is exceeded.
- Inrush current or an abnormal current / voltage can be detected by sampling the inputs at every 1.6ms.
- LED blinks when the measured values exceed the preset current / voltage value.

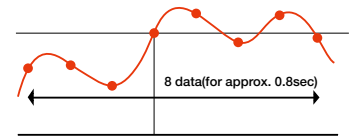

Capture recording mode

For observing waveforms easily.

- Waveform display via a PC by sampling the inputs every 0.55ms.
- When the preset current / voltage value is exceeded, instantaneous values are recorded for 200ms (from 10(50Hz) to 12 (60Hz) waveforms) before and after preset value is exceeded.
- LED blinks when the measured values exceed the preset current / voltage value.

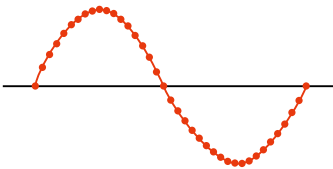

Power Quality Analysis Mode

For monitoring and observing voltage fluctuations.

- Detects the reference voltage, Swell, Dip and Short Interruption. Records the values detected with the start time and end time.
- Samples the inputs every 0.55ms and detects the voltage fluctuation every 10ms.
- LED blinks when the voltage fluctuation is detected.

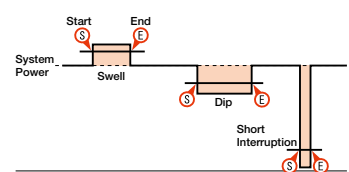

Analyzing and processing the recorded data with a PC

The user friendly PC software "KEW LOG Soft 2" is supplied.

Software is Enhanced!



- The type of the sensor connected to the logger will be automatically recognized.
- Just click appropriate dialog boxes for set up if it is not required to input any comments.
- By using commercially available USB hub, multiple loggers can be connected to a PC and can set the synchronized time.

System requirements

- OS: Windows® 11/10
 - Display: XGA(Resolution 1024 x 768 dots) or more
 - Required HDD space: 1Gbyte or more
 - Others: With CD-ROM drive and USB port
- * Windows® is a registered trademark of Microsoft in the United States.

A graph can be made by just one click

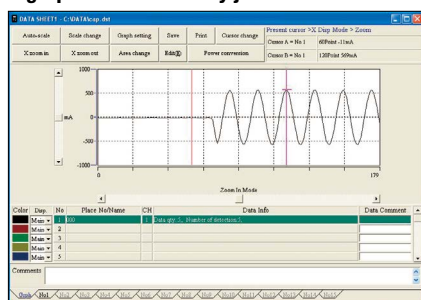

Display of Power Quality

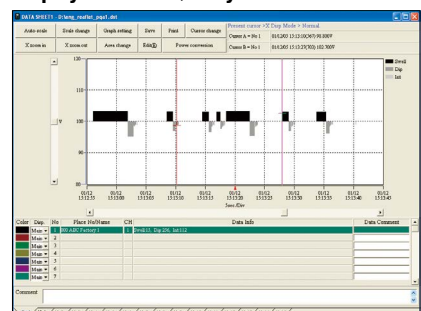

Selection Guide of Loggers

	Loggers		
	5010	5020	5050
Appearance			
Voltage [V]	—	✓	✓
Current [A]	✓	✓	✓
Ior Resistive leakage current [mA]	—	—	✓
Frequency [Hz]	—	—	✓
Power Quality	Swell	—	✓
	Dip	—	✓
	Interruption	—	✓
Inrush Current	✓	✓	—
Memory	Inner memory	Inner memory	SD card
Number of Input Channel	3ch	3ch	5ch (V1, A4)

KEW 5050



KEW 5050 is an innovative Leakage Current Logger that can identify the resistive component of leakage current (Ior) in an electrical installation. Despite the capacitive component, the Ior is the dangerous component of the leakage current because Ior consumes power and then it can cause a rise in temperature that can lead to a fire and electric shock.

- Provides simultaneous measurements and logs up to 4 channels
- Supports various wiring systems
(Single-phase 2&3-wire, Three-phase 3&4-wire*) *Except Ior for 3 Phase 4 wire
- World's fastest class speed at 200ms interval for leakage current measurement
- Offers both traditional leakage / load current measurements
- Large graphic display and magnet on the back case to attach it on metal enclosures

Can measure up to 4 channels simultaneously!

Best to diagnose unwanted RCD tripping



The RCD often trips. Is the cause due to capacitive leakage current or the dangerous resistive leakage current of a degraded insulation?

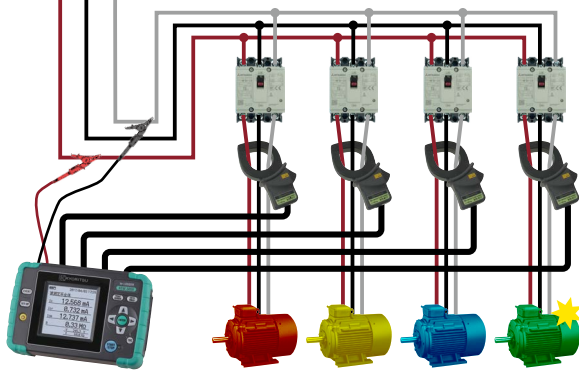

Gapless continuous measurement

Performs fast sampling (24.4 μs) continuously with gapless during logging to prevent intermittent leakages being overlooked as an event or max value.

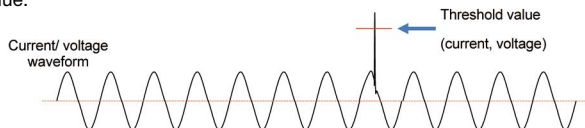

	5050
Wiring configuration	1P2W, 1P3W, 3P3W, 3P4W
Measurements and parameters	Ior : Leakage current (TRMS) with resistive components only Io : Leakage current (TRMS) with basic wave of 50/60Hz only Iom : Leakage current (TRMS) including harmonic components V : Reference voltage (TRMS) with basic wave of 50/60Hz only Vm : Reference voltage (TRMS) including harmonic components R : Insulation resistance, Frequency(Hz), Phase angle(θ)
Other functions	Digital output, Print screen, Backlight, Data hold
Recording Interval	200/400ms/1/5/15/30s/1/5/15/30m/1/2hours
Ior	
Range	10.000/100.00/1000.0mA/10.000A/AUTO
Accuracy	For reference voltages of sine wave 40 - 70Hz and 90V TRMS or higher, ±0.2%rdg±0.2%f.s. + clamp sensor amplitude accuracy + error of phase accuracy* (phase error) * add ±2.0%rdg to measured Io value when using Ior leakage clamp sensor. (θ : within the accuracy of reference voltage/ current phase difference ±1.0°)
Allowable input	1% - 110% (TRMS) of each range, and 200% (peak) of the range
Display range	0.15% - 130% (display "0" for less than 0.15%, "OL" if the range is exceeded)
Io *Range, Allowable input and Display Range are the same as Ior .	
Accuracy	±0.2%rdg±0.2%f.s.+ clamp sensor amplitude accuracy
Iom *Range, Allowable input and Display Range are the same as Ior .	
Accuracy	±0.2%rdg±0.2%f.s.+ clamp sensor amplitude accuracy
Measurement method	Sampling speed 40.96ksps (every 24.4μs), gapless, calculate TRMS values every 200ms.
Voltage	
Range	1000.0V
Accuracy	±0.2%rdg±0.2%f.s. * for waveforms of sine wave 40 - 70Hz
Allowable input	10 - 1000V TRMS, and 2000V peak
Display range	0.9 - 1100.0V TRMS (display "0" for less than 0.9V, "OL" if the range is exceeded)
Phase angle(θ)	
Display range	0.0 - ±180.0° (regarding the phase of reference voltage as 0.0°)
Accuracy	Within ±0.5° for the inputs of 10% or higher of leakage current range, sine wave 40 - 70Hz, reference voltage of 90V TRMS or higher. Within ±1.0° when using Ior leakage clamp sensor, and Within ±0.5°+ clamp sensor accuracy when using general purpose clamp sensor.
Frequency meter range	40 - 70Hz
External supply	AC100 - 240V(50/60Hz) 7.5VA max
Power source	LR6(AA)(1.5V) × 6 (Battery life approx. 11h)
Display / update period	160 × 160dots, FSTN monochrome display / 500ms
PC card interface	SD card (2GB) *standard accessory
Communication interface	USB
Temperature and humidity range	23±5°C, relative humidity 85% or less(no condensation)
Operating temperature and humidity range	-10 - 50°C, relative humidity 85% or less(no condensation)
Storage temperature and humidity range	-20 - 60°C, relative humidity 85% or less(no condensation)
Applicable Standards	IEC 61010-1 CAT IV 300V / CAT III 600V Pollution degree 2 IEC 61010-2-030, IEC 61010-031, IEC 61326
Dimension / Weight	165(L) × 115(W) × 57(D)mm / Approx. 680g (including batteries)
Accessories	7273(Voltage test lead) 8262(AC adapter) 7278(Earth cable) 7219(USB cable) 8326-02(SD card [2GB]) 9125(Carrying case) Instruction manual, Cable marker, Software installation manual LR6(AA) × 6 KEW Windows for KEW 5050(Software)
Optional Accessories	8177(Ior Leakage current Clamp Sensor 10A type φ40mm) 8178(Ior Leakage current Clamp Sensor 10A type φ68mm) 8329(Power supply adapter)
Optional sensors (It cannot be used for Ior measurement)	8146, 8147, 8148 (Leakage & Load current Clamp Sensor) 8130, 8133 (Flexible Clamp Sensor) 8121, 8122, 8123 (Load current Clamp Sensor) 8124, 8125, 8126, 8127, 8128 (Load current Clamp Sensor)

Shows insulation resistance (R) values determined by the following formula.

V: Reference voltage/ Ior: Leakage current

Displayed value is just for reference since the measurement method differs from insulation resistance testers and may not be consistent with each other.

In case of 3P3W and 3P4W, for a correct Ior reading, the capacitance effect of each phase must be equal.

Ior LOGGER

Quickly displays occurred events

Detailed information on the occurred events are displayed on the LCD. Different threshold values can be set for each channel and each event.

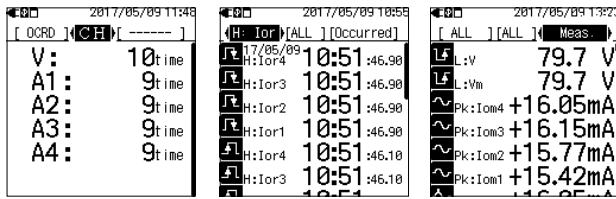

Various display modes

User-friendly graphical display of connections and phase differences

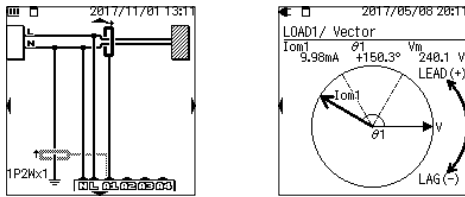

New Measurement method with FFT

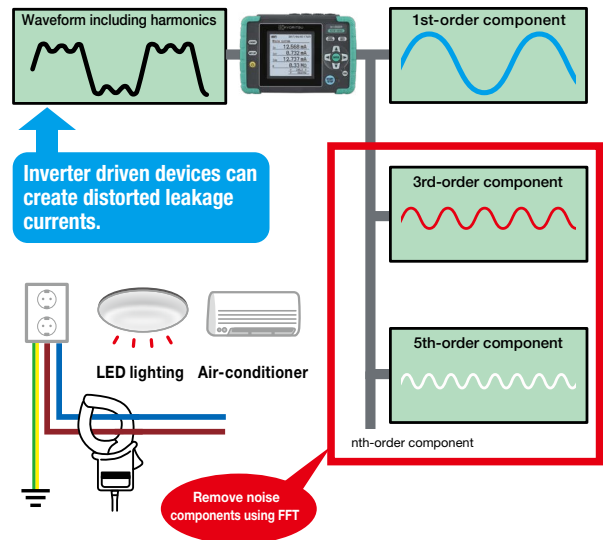

Unlike to traditional measuring apparatus, less susceptible to harmonics noises.

Successfully achieving logging with no effects of harmonics by True RMS calculation every 200 ms using FFT (Fast Fourier Transform).

Windows software

Automatic generation of graphs and lists based on the recorded data by just one click. Data can be checked without using this software by changing the file extension to csv or others.

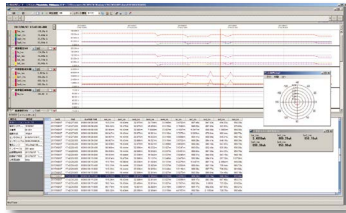

System requirements

OS: Windows® 11/10
 Display: XGA (1024 × 768) or more
 Required HDD space: 1Gbyte or more
 Others: CD-ROM drive, USB port, .NET Framework 3.5, 4.6
 * Windows® is a registered trademark of Microsoft in the United States.

SD card interface

Achieves long period of data logging. In case of sudden power interruption, data stored in the SD card aren't lost.

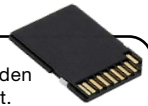

Interval	Possible recording time (with 2GB SD card)		
	REC item		
	1P3W × 1	1P3W × 4	3P4W × 4
200 ms	25 days	8 days	7 days
1 sec.	38 days	11 days	9 days
2 sec.	76 days	22 days	18 days
5 sec.	6.5 months	1.8 months	1.5 months
15 sec.	1 year or more	5 months	4 months
30 sec.		11 months	9 months
1 min. or more		1 year or more	

Accessories

MODEL 7273
Voltage test lead
3,000mm

MODEL 8262
AC adapter

MODEL 7278
Earth cable
1,500mm

MODEL 7219
USB cable
1,950mm

MODEL 8326-02
SD card [2GB]

MODEL 9125
Carrying case

KEW Windows for KEW 5050 Software

Cable marker

Optional Accessories

Ior Leakage current Clamp Sensor

KEW 8178

MAX 10A Ø68

KEW 8177

MAX 10A Ø40

Power supply adapter

MODEL 8329

Power source can be taken through the measured line (100 - 240V) (Fuse : 8923)

Kits

KEW 5050-01

+ KEW 8178 (φ68) × 1

KEW 5050-02

+ KEW 8177 (φ40) × 1

KEW 5050 × 1
Carrying case: MODEL 9125

Optional Accessories of Loggers, Power Meter and Power Quality Analyzer

Applicable model table

			5010	5020	5050	6305	6315
Sensor	Load current	8121	✓	✓	✓*6		
		8122	✓	✓	✓*6		
		8123	✓	✓	✓*6		
		8124	✓	✓	✓*6	✓	✓
		8125	✓*1	✓*1	✓*6	✓	✓
		8126	✓*2	✓*2	✓*6	✓	✓
		8127	✓*3	✓*3	✓*6	✓	✓
		8128	✓	✓	✓*6	✓	✓
	Flexible type	8130	✓*4	✓*5	✓*6	✓	✓
		8133			✓*6	✓	✓
		8135	✓	✓		✓	✓
	Leakage & Load current	8146	✓	✓	✓*6		✓*7
		8147	✓	✓	✓*6		✓*7
		8148	✓	✓	✓*6		✓*7
Ior Leakage current	8177			✓			
	8178			✓			
Voltage sensor	8309		✓				
Adapter	8312				✓	✓	
	8320	✓	✓				
	8329			✓			
Case	9132				✓	✓	
	9135	✓	✓				

*1-5: Sensors can be used from the following serial numbers onwards.

*1: 8125 No.02637 -

*2: 8126 No.00151 -

*3: 8127 No.00181 -

*4: 5010 No.8029792 -

*5: 5020 No.8031560 -

*6: Cannot be used for Ior measurement.

*7: Cannot be used for power measurement.

MODEL 8312

Power supply adapter



Power source can be taken from the measured line (100 - 240V)(Fuse : 8923)

MODEL 9132

Carrying case with magnet



Easy-to-use setting with magnet on the steel plate etc. of switch board

MODEL 8320

AC adapter (External power supply)



Appropriate for a longer period of recording. Complies to 90 - 264V(45 - 66Hz).

MODEL 9135

Carrying case



Dimension: 250(L) × 270(W) × 216(D)mm

MODEL 8329

Power supply adapter



Power source can be taken from the measured line (100 - 240V)(Fuse : 8923)

Ior Leakage current Clamp sensors

KEW **8177**

KEW **8178**

MAX 10A Ø40

MAX 10A Ø68



	8177	8178
Conductor size	φ40mm	φ68mm
Rated current	10A (rms) AC (14.1Apeak)	
Output voltage	500mV AC/10A AC	
Accuracy	±1.0%rdg±0.025mV (40 - 70Hz) ±4.0%rdg±0.025mV (30Hz - 5kHz, with inputs of 100mA or more)	
Phase shift	within 1.0° (45 - 70Hz while combining with KEW 5050, under the input of 10% or more of KEW 5050 leakage current range)	
Cable length : Output connector	Approx. 3m : MINI DIN 6PIN	
Operating temperature and humidity range	-10 - 50°C, relative humidity 85% or less (no condensation)	
Output impedance	Approx. 100Ω or less	Approx. 60Ω or less
Applicable Standards	IEC 61010-1, IEC 61010-2-032 CAT III 300V Pollution degree 2, IEC 61326-1	
Dimension	128(L) × 81(W) × 36(D)mm	186(L) × 129(W) × 53(D)mm
Weight	Approx. 280g	Approx. 560g
Accessories	9095 (Carrying case) Instruction manual, Cable marker	9094 (Carrying case) Instruction manual, Cable marker
Applicable model	5050	

Voltage sensor

KEW **8309**



	8309
Max. input voltage	AC 600Vrms(sin), 848.4Vpeak
Input system	Differential input (can measure floating voltage)
Output voltage	AC 0 - 60mV (output/input : 0.1mV/V)
Measuring ranges	6 - 600V
Accuracy	±1.0%rdg±0.1mV (50/60Hz)
Operating temperature and humidity range	-10 - 50°C, relative humidity 85% or less (no condensation)
Input impedance	Approx. 3.4MΩ
Output impedance	Approx. 180Ω
Cable length: Output connector	Approx. 2m : MINI DIN 6PIN
Applicable Standards	IEC 61010-1 CAT III 600V Pollution degree 2 IEC 61010-031, IEC 61326 (EMC)
Dimension / Weight	87(L) × 26(W) × 17(D)mm (excluding protrusions) / Approx. 135g
Accessories	Instruction manual
Optional Accessories	7185 (Extension cable)
Applicable model	5020

SENSORS

Load current flexible Clamp sensors

KEW 8135



KEW 8130



KEW 8133



	8135	8130	8133
Conductor size	max. ϕ 75mm	max. ϕ 110mm	max. ϕ 170mm
Rated current	AC 5A(Max.50A)	AC 1000A	AC 3000A
Output voltage	AC 500mV/50A (AC 10mV/A)	AC 500mV/1000A (AC 0.5mV/A)	AC 500mV/3000A (AC 0.167mV/A)
Accuracy	$\pm 1.0\%$ rdg ± 0.5 mV (45 - 65Hz) (0 - 50A) $\pm 1.5\%$ rdg ± 0.5 mV (40 - 300Hz) (0 - 20A) $\pm 1.5\%$ rdg ± 0.5 mV (300Hz - 1kHz) (0 - 5A)	$\pm 0.8\%$ rdg ± 0.2 mV (45 - 65Hz) $\pm 1.5\%$ rdg ± 0.4 mV (40Hz - 1kHz)	$\pm 1.0\%$ rdg ± 0.5 mV (45 - 65Hz) $\pm 1.5\%$ rdg ± 0.5 mV (40Hz - 1kHz)
Phase shift	within $\pm 3.0^\circ$ (45 - 65Hz), within $\pm 4.0^\circ$ (40Hz - 1kHz)	within $\pm 2.0^\circ$ (45 - 65Hz), within $\pm 3.0^\circ$ (40Hz - 1kHz)	
Cable length : Output connector	Approx. 3m : MINI DIN 6PIN		
Operating temperature and humidity range	-10 - 50°C, relative humidity 85% or less (no condensation)		
Output impedance	100 Ω or less		
Applicable Standards	IEC 61010-1, IEC 61010-2-032 CAT IV 300V CAT III 600V Pollution degree 2, IEC 61326	IEC 61010-1, IEC 61010-2-030, IEC 61010-2-032 CAT IV 300V /CAT III 600V Pollution degree 2, IEC 61326	
Dimension	AMP box 65(L) \times 24(W) \times 22(D)mm(except for protrusions)		
Weight	Approx. 170 g	Approx. 180g	Approx. 200g
Accessories	Instruction manual Cable marker 9095(Carrying case)		
Applicable models	5010, 5020, 6305, 6315	5010, 5020, 5050(Cannot be used for lor measurement.), 6305, 6315	5050(Cannot be used for lor measurement.) 6305, 6315

Load current Clamp sensors

MODEL 8128

MODEL 8127

MODEL 8126

MODEL 8125

MODEL 8124



	8128	8127	8126	8125	8124
Conductor size	ϕ 24mm	ϕ 24mm	ϕ 40mm	ϕ 40mm	ϕ 68mm
Rated current	AC 5A (Max.50A)	AC 100A	AC 200A	AC 500A	AC 1000A
Output voltage	AC 50mV/5A [Max. 500mV/50A](AC 10mV/A)	AC 500mV/100A (AC 5mV/A)	AC 500mV/200A (AC 2.5mV/A)	AC 500mV/500A (AC 1mV/A)	AC 500mV/1000A (AC 0.5mV/A)
Accuracy	$\pm 0.5\%$ rdg ± 0.1 mV (50/60Hz) $\pm 1.0\%$ rdg ± 0.2 mV (40Hz - 1kHz)				$\pm 0.5\%$ rdg ± 0.2 mV (50/60Hz) $\pm 1.5\%$ rdg ± 0.4 mV (40Hz - 1kHz)
Phase shift	within $\pm 2.0^\circ$ (45 - 65Hz)		within $\pm 1.0^\circ$ (45 - 65Hz)		
Cable length : Output connector	Approx. 3m : MINI DIN 6PIN				
Operating temperature and humidity range	0 - 50°C, relative humidity 85% or less (no condensation)				
Output impedance	Approx. 20 Ω	Approx. 10 Ω	Approx. 5 Ω	Approx. 2 Ω	Approx. 1 Ω
Applicable Standards	IEC 61010-1, IEC 61010-2-032 CAT III 300V Pollution degree 2 IEC 61326		IEC 61010-1, IEC 61010-2-032 CAT III 600V Pollution degree 2 IEC 61326		
Dimension	100(L) \times 60(W) \times 26(D)mm		128(L) \times 81(W) \times 36(D)mm		186(L) \times 129(W) \times 53(D)mm
Weight	Approx. 160g		Approx. 260g		Approx. 510g
Accessories	9095 (Carrying case), Instruction manual, Cable marker				9094 (Carrying case) Instruction manual, cable marker
Optional Accessories	7146 (Banana ϕ 4 adjuster plug), 7185 (Extension cable)				
Applicable models	5010, 5020, 5050(Cannot be used for lor measurement.), 6305, 6315				

SENSORS

Leakage & Load current Clamp sensors

KEW 8146

MAX 30A Ø24



KEW 8147

MAX 70A Ø40



KEW 8148

MAX 100A Ø68



	8146	8147	8148
Conductor size	φ24mm	φ40mm	φ68mm
Rated current	AC 30A	AC 70A	AC 100A
Output voltage	AC 1500mV/30A (AC 50mV/A)	AC 3500mV/70A (AC 50mV/A)	AC 5000mV/100A (AC 50mV/A)
Accuracy	0 - 15A ±1.0%rdg±0.1mV (50/60Hz)±2.0%rdg±0.2mV (40Hz - 1kHz) 15 - 30A ±5.0%rdg (50/60Hz),±10.0%rdg (45Hz - 1kHz)	0 - 40A ±1.0%rdg±0.1mV (50/60Hz),±2.0%rdg±0.2mV (40Hz - 1kHz) 40 - 70A ±5.0%rdg (50/60Hz),±10.0%rdg (45Hz - 1kHz)	0 - 80A ±1.0%rdg±0.1mV (50/60Hz),±2.0%rdg±0.2mV (40Hz - 1kHz) 80 - 100A ±5.0%rdg (50/60Hz),±10.0%rdg (45Hz - 1kHz)
Cable length : Output connector	Approx. 2m : MINI DIN 6PIN		
Operating temperature and humidity range	0 - 50°C, relative humidity 85% or less (no condensation)		
Output impedance	Approx. 90Ω	Approx. 100Ω	Approx. 60Ω
Applicable Standards	IEC 61010-1, IEC 61010-2-032 CAT III 300V Pollution degree 2, IEC 61326		
Dimension	100(L) × 60(W) × 26(D)mm	128(L) × 81(W) × 36(D)mm	186(L) × 129(W) × 53(D)mm
Weight	Approx. 150g	Approx. 240g	Approx. 510g
Accessories	9095(Carrying case), Instruction manual, Cable marker		9094 (Carrying case), Instruction manual, Cable marker
Optional Accessories	7146(Banana φ4 adjuster plug), 7185(Extension cable)		
Applicable models	5010, 5020, 5050(Cannot be used for Ior measurement.), 6315(Cannot be used for power measurements.)		

Load current Clamp sensors

KEW 8121

MAX 100A Ø24



KEW 8122

MAX 500A Ø40



KEW 8123

MAX 1000A Ø55



	8121	8122	8123
Conductor size	φ24mm	φ40mm	φ55mm
Rated current	AC 100A	AC 500A	AC 1000A
Output voltage	AC 500mV/100A (AC 5mV/A)	AC 500mV/500A (AC 1mV/A)	AC 500mV/1000A (AC 0.5mV/A)
Accuracy	±2.0%rdg±0.3mV (50/60Hz), ±3.0%rdg±0.5mV (40Hz - 1kHz)		
Cable length : Output connector	Approx. 2m : MINI DIN 6PIN		
Operating temperature and humidity range	0 - 40°C, relative humidity 85% or less (no condensation)		
Output impedance	Approx. 9.5Ω	Approx. 1.9Ω	Approx. 1.5Ω
Applicable Standards	IEC 61010-1, IEC 61010-2-032 CAT III 300V Pollution degree 2, IEC 61326		
Dimension	97(L) × 59(W) × 26(D)mm	128(L) × 81(W) × 36(D)mm	170(L) × 105(W) × 48(D)mm
Weight	Approx. 150g	Approx. 260g	Approx. 360g
Accessories	9095(Carrying case), Instruction manual, Cable marker		9094(Carrying case), Instruction manual, Cable marker
Optional Accessories	7146(Banana φ4 adjuster plug), 7185(Extension cable)		
Applicable models	5010, 5020, 5050(Cannot be used for Ior measurement.)		

INTELLIGENT SOCKET TESTERS



INTELLIGENT SOCKET TESTERS

KEW **4506** **NEW**



- Easy measurement by simply plugging into a socket outlet and pressing the test button
- In only 1 second you can check voltage, correct wiring and polarity of Line, Neutral and Earth of a socket outlet
- KEW 4506 can be used on TT earth system, and also on TN-S by combined use with KEW 8343 (See measurement principle)
- Unique measurement method with low test current for avoiding tripping of RCDs



4506			
Socket test*1			
Measurable range of power supply voltage	80 to 290V rms (50/60Hz) *The tester gives voltage warning if 253V or higher voltage is detected but it can perform socket test.		
Socket type	3 Pole	2 Pole	
Judgement	PASS	PASS	PASS
	FAIL	L-N Reverse	L-N Reverse
		L-E Reverse	Abnormal voltage
	N-E Reverse	-	-
	E Not connected	-	-
	N Not connected	-	-
	N-E unjudgeable	-	-
	Abnormal voltage	-	-
AC V (L-N)			
Range	80 to 290V rms (50/60Hz)		
Accuracy	±2%rdg±4dgt		
Loop resistance (N-E)			
Range (Auto-ranging)	200Ω: 0.0 to 199.9Ω 2000Ω: 200 to 1999Ω		
Test current	200Ω: 5mA (5.3 Hz) 2000Ω: 1mA (5.3 Hz)		
Accuracy	±3%rdg±5dgt		
Applicable Standards	IEC 61010-1, IEC 61010-2-030 CAT II 300V Pollution degree 2, IEC 60529(IP40)		
Operating temperature & humidity range	-10 - 50°C, relative humidity 85% or less (no condensation)		
Storage temperature & humidity range	-20 - 60°C, relative humidity 85% or less (no condensation)		
Power source	LR6 (AA)(1.5V) × 2		
Dimension	212(L) × 56(W) × 39(D) mm		
Weight	Approx. 250g (including batteries)		
Accessories	KAMP 10 or 7284(Test lead with IEC connector) 9161 (Carrying case) LR6 (AA) × 2, Instruction manual		
Optional Accessories	8343(Signal Source for Intelligent Socket Tester)		

*1 If N-E resistance measurement function is turned off*2, test is performed with a test voltage applied from an optional signal source only: current flows between N-E is less than 1μA.

*2 If the function is disabled, KEW 4506 doesn't show resistance between N-E.

INTELLIGENT SOCKET TESTERS



KAMP 10 or MODEL 7284
1,500mm 720mm
Test lead with IEC connector

Applicable to the socket outlet types of each country



KAMP 10(AU) : Australian plug
KAMP 10(EU) : European SCHUKO plug
KAMP 10(UK) : British plug (13A)
7284 : American(NEMA)plug



MODEL 9161
Carrying case

KEW **8343** **NEW**



8343		
Conductor size	φ24mm max.	
Test voltage	Freq.	Approx. 1.8kHz
	TRMS	Approx. 20mV rms
Allowable input range	300V AC rms (50/60Hz) continuous 100A AC (50/60Hz) continuous	
Operating temperature & humidity range	-10 - 50°C, relative humidity 85% or less (no condensation)	
Storage temperature & humidity range	-20 - 60°C, relative humidity 85% or less (no condensation)	
Power source	LR6 (AA)(1.5V) × 6	
Applicable Standards	IEC 61010-1, IEC 61010-031, IEC 61010-2-032 CAT III 300V Pollution degree 2, IEC 60529(IP40)	
Dimension	Unit: 112(L) × 61(W) × 42(D) mm Test voltage injection clamp: 100(L) × 60(W) × 26(D) mm Cable length: Approx. 1.5m	
Weight	Approx. 520g (including batteries)	
Accessories	7157B (Alligator clips) 9096 (Carrying case) LR6 (AA) × 6, Instruction manual	

MODEL 7157B
Alligator clips



MODEL 9096
Carrying case



INTELLIGENT SOCKET TESTERS

Where to use

KEW 4506 can test the wiring connection including the N-E Reverse of single-phase socket outlets. This tester can test single phase socket outlets wired to Three-phase 4-Wire, Single-phase 3-Wire, Single-phase 2-Wire supply systems.

*KEW 4506 cannot be used for checking three-phase socket outlets and testing the RCD.

For use in a general TN system circuit, N-E Reverse can be determined only at socket outlets connected downstream of the N conductor where KEW 8343 is clamped.

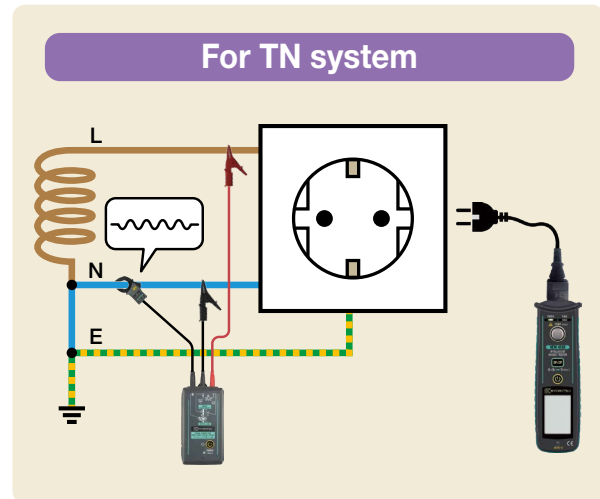
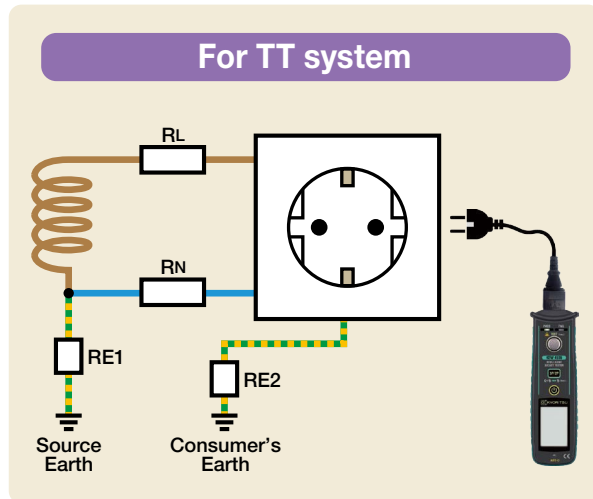

All test results and PASS/FAIL in a clear display screen



Easy measurement by simply plugging into a socket outlet and pressing the test button.



LCD backlight automatically turns on at the dark place.

*It is possible to disable backlight

Wiring check with the live circuit condition

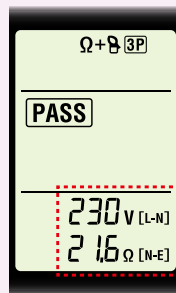

L-N voltage and N-E resistance at TT system can be displayed.

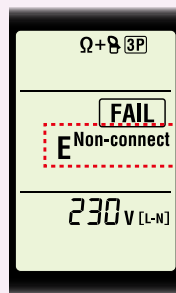

Non-connect can be also displayed.

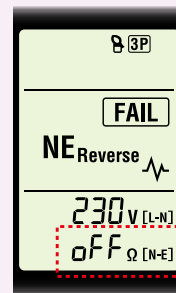

KEW 4506 has a mode which can detect the wiring connection avoiding any RCD tripping.

*resistance measurement OFF

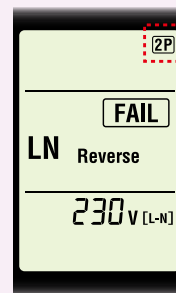

Wiring check for 2P(no earth) outlet is also available by selecting the 2P setting.

*2P conversion adapter which is required to connect with 2P outlet isn't supplied.

KEW 5204/5204BT

DIGITAL LIGHT METER



DATA HOLD 
MAX/MIN  Bluetooth

photo : 5204BT



- Detachable & Rotatable Light Sensor
- Data Hold Function
- MAX/MIN Function
- Large LCD with Backlight
- LED illuminance can be measured

 **Wireless communication with smart-phone or tablet (5204BT only)**



	5204/5204BT
Measuring Range	0.0 - 199900 lx
Ranges	199.9/1999/19990/199900 lx
Accuracy	±4%rdg±5dgt (23°C±2°C)
Angle deviation from cosine characteristics	10° ±1.5%, 30° ±3%, 60° ±10%, 80° ±30%
Relative spectral sensitivity characteristics	Deviation from spectral luminous efficiency:9%
Response time	Auto-ranging:5s or less Manual ranging:2s or less
Operating temperature and humidity range	0 - 40°C, 80% RH or less (no condensation)
Storage temperature and humidity range	-10 - 60°C, 70% RH or less (no condensation)
Communication Interface	Bluetooth®5.0*1
Applicable Standards	IEC 61326 , JIS C 1609-1:2006
Power source	LR/R6(AA)(1.5V) × 2
Dimension	169(L) × 63(W) × 37(D)mm
Weight	Approx. 210g
Accessories	9195(Carrying case), LR6(AA) × 2, Instruction Manual

*1 5204BT only.
Some countries regulate the compliance with their Radio Law of the products equipped with Bluetooth®.
Please confirm it with your distributor before purchasing our products equipped with Bluetooth®.
*LED illuminance measurements are verified by testing only the typical illuminance, frequency, and duty ratio of pulsed white LED.

KEW Smart Advanced application streamlines report creation.

Download and install our special application "KEW Smart Advanced" in your smartphone or tablet device for logging the measured values. Measured values can be saved in your smartphone or tablet device in csv format: the data is editable in excel format.



MODEL 5202

DIGITAL LIGHT METER

- 3 ranges changeable from low to high illuminance (200/2000/20000Lux)
- Data hold function
- Digital light meter with separate light receiving sensor and meter



	5202
Ranges	0.1 - 19990Lux
Accuracy (23°C±5°C)	Lux Accuracy 200 ±4%rdg±5dgt 2000 ±4%rdg±5dgt 20000 ±5%rdg±4dgt
Current consumption	Approx. 2mA
Response time	2.5 times / sec.
Operating temperature and humidity range	0 - 50°C, relative humidity 80% or less (no condensation)
Storage temperature and humidity range	-10 - 60°C, relative humidity 70% or less (no condensation)
Angular incident light characteristics	30°less than ±3% 60°less than ±10% 80°less than ±30%
Power source	6F22(9V) × 1
Dimension	Meter:148(L) × 71(W) × 36(D)mm Light receiving sensor:80(L) × 67(W) × 32(D)mm
Weight	Approx. 270g
Accessories	Carrying case 6F22 × 1 Photocell cover Instruction manual

KEW 5711

Voltage Detector

CAT IV 600V

- Senses AC voltage through insulation
- Buzzer sounds and tip glows upon AC voltage detection
- Powerful flashlight
- Dual range (Hi/Lo) sensitivity
- Ready to use without power-on
- Designed to meet IEC 61010-1



	5711
Operating voltage	AC 90 - 1000 V(Lo sensitivity) AC 20 - 1000 V(Hi sensitivity)
Frequency range	50/60Hz
Operating temperature range	-10 - 50°C
Storage temperature range	-20 - 60°C
Applicable Standards	IEC 61010-1 CAT IV 600V / CAT III 1000V Pollution degree 2
Power source	LR03 / R03(AAA)(1.5V) × 2
Dimension	153(L) × φ20mm
Weight	Approx. 40g (including batteries)
Accessories	LR03(AAA) × 2, Instruction manual

LED light



Bright Red Indicator



KEW 8035

Non-Contact Safety Phase Indicator

CAT IV 600V



- New technology permits safe testing, without the need of direct contact between probes and live wires
- The insulated alligator clips can clip insulated cables from $\phi 2.4$ to 30mm
- Phase rotation is indicated by the rotary illumination of LEDs and logical audible tones
- A magnet on the backside of the instrument can fix the instrument onto the distribution board
- Wide measuring range for 3 phase installations from 70 to 1000V AC
- Super brightness function permits clear LEDs indication also in sunshine

	8035
Functions	Phase rotation (Clockwise or Counter Clockwise), Presence of open phase
Detection method	Electrostatic induction
Measuring voltage range	From 70 - 1000V AC phase to phase (sine wave, continuous input)
Clamp diameter range	From $\phi 2.4$ to 30mm insulated cables
Measuring frequency range	45 to 66Hz
Phase rotation	Clockwise: Green arrow LEDs "rotate" in clockwise, Green symbol "CW" lits, Intermittent buzzer Counter Clockwise: Red arrow LEDs "rotate" in counter clockwise, Red symbol "CCW" lits, continuous buzzer
Visual indication	LEDs with Super brightness function
Battery voltage warning	Power LED blinks if battery voltage is too low.
Operating temperature and humidity range	-10 - 50°C, relative humidity 80% or less (no condensation)
Storage temperature and humidity range	-20 - 60°C, relative humidity 80% or less (no condensation)
Applicable Standards	IEC 61010-1 CAT IV 600V / CAT III 1000V Pollution degree2
Power source	LR6(AA)(1.5V) \times 4 * Continuous use: Approx. 100 hours (Auto power off in about 10 min.)
Dimension	112(L) \times 61(W) \times 36(D) mm
Weight	Approx. 380g
Test leads	Double insulated cables, length Approx. 70cm
Colours leads	L1(U): Red L2(V): White L3(W): Blue
Accessories	9096 (Carrying case), LR6(AA) \times 4, Instruction manual

KEW 8031 ^{NEW} / 8031F

PHASE INDICATOR with open phase checker

PHASE INDICATOR with fused test leads



photo : 8031F



KEW 8031 CE type



KEW 8031 Standard type

	8031		8031F
	Standard Type	CE Type	
Operational voltage	110 - 600V AC		
Fuse	—		0.5A/600V (F)
Time limit for continuous	>500V : within 5 minutes		
Frequency response	50/60Hz		
Applicable Standards	—		IEC 61010-1 CAT IV 300V, CAT III 600V Pollution degree 2
Dimension	106(L) \times 75(W) \times 40(D)mm		
Weight	Approx. 350g(Main unit only)		
Cord	1.5m(R : red S : white T : blue)		1.3m(R:red S:white T:blue)
Accessories	9029(Carrying case) Instruction manual		8923(Fuse [0.5A/600V]) 9094(Carrying case) Instruction manual

- Phase indicator designed to check the presence of open phase and also the phase sequence by rotating disk and lamps
- Can check a wide range of 3-phase power source from 110V to 600V Sealed against dust, the unit ensures trouble-free performance
- Small, Lightweight and portable. Designed for maximum ease of operation and ruggedness
- No exposed metal parts, Safety features are incorporated including the instant push button switch operation (8031F only)

KEW 5515

Infrared Thermometer



- Single laser allows more accurate measurements
- Backlight display helps to read in a dark place
- Dual display: Main display shows the measured values and Sub display shows either of max, min, average or thermocouple value
- Alarm function: The upper and lower temperature limits can be set
- The red blinking Backlight indicates that the measured value is below or over the pre-set limits

	5515
Measuring range	-32 - 535°C
Accuracy	$\pm 3.0^\circ\text{C}$ (-32 - 20°C), $\pm 2.0^\circ\text{C}$ (-20 - +100°C), $\pm 2\%$ rdg(100 - 535°C)
Infrared spectral band	5 - 14 μm
Measuring diameter	1000mm/ $\phi 78\text{mm}$ (Distance/ Measuring dia.: 12:1)
Repeatability	Within $\pm 1^\circ\text{C}$
Emissivity	Variable between 0.10 and 1.00 (by 0.01 steps), Before shipment: 0.95
Collimation	Laser beam (630 - 670nm 1mW or less) specifies the center.
Thermocouple	K-type*
Measuring range of thermocouple	-199 - 1372°C
Accuracy of thermocouple	$\pm 1.5\%$ rdg+1°C (-40 - 1372°C)
Response	500ms
Resolution	0.1°C
Auto power off	If no key is pressed for 6 seconds, the power is shut off automatically.
LCD display	LCD with backlight (blinks in red when alarm function is activated)
Dual display	Simultaneous display (Measured value and either of max, min, average or thermocouple value)
Operating temperature & humidity	0 - 50°C / 10 - 90% RH
Applicable Standards	IEC 61326, IEC 61000-4-2, IEC 61000-4-3, IEC 61000-4-8
Power source	6F22(9V) \times 1
Dimension	180(L) \times 130(W) \times 40(D)mm
Weight	Approx. 195g (excluding battery)
Accessories	9152(Carrying case), 6F22(9V) \times 1, Instruction manual

*Commercial K-type thermocouple can be used with the product.



KT 200

AC CLAMP METER

Ø30 MAX 400A AC A DC AC V Ω ●●)

DATA HOLD AUTO POWER SAVE

- Small and handy clamp meter
- IEC 61010-1 Safety Standard CAT III 300V / CAT II 600V
- 400A AC Clamp meter
- DMM function ACV, DCV, Ω Continuity Buzzer

	KT 200
AC A	40.00/400.0A ±2.0%rdg±6dgt(50/60Hz)
AC V	400.0/600V(Auto-ranging) ±2.0%rdg±5dgt(50/60Hz)
DC V	400.0/600V(Auto-ranging) ±1.5%rdg±5dgt
Ω	400.0/4000Ω(Auto-ranging) ±2.0%rdg±5dgt
Continuity buzzer	Buzzer sounds below 50±35Ω
Conductor size	φ30mm max.
Applicable Standards	IEC 61010-1 CAT III 300V(ACA) / CAT II 600V Pollution degree 2 IEC 61010-2-032, IEC 61326-1
Power source	R03(1.5V)(AAA) × 2 *Continuous measuring time:Approx.200 hours(Auto power save: Approx.10 min.)
Dimension	184(L) × 44(W) × 27(D)mm
Weight	Approx. 190g(including batteries)
Accessories	7066A(Test leads), R03(AAA) × 2, Instruction manual
Optional Accessories	9105(Carrying case)

CE



KT 203

AC/DC CLAMP METER

Ø30 MAX 400A DC AC A DC AC V Ω ●●)

DATA HOLD AUTO POWER SAVE

- Small and handy clamp meter
- IEC 61010-1 Safety Standard CAT III 300V / CAT II 600V
- 400A AC/DC Clamp meter
- DMM function ACV, DCV, Ω Continuity Buzzer

	KT 203
AC A	40.00/400.0A (Auto-ranging) ±3.0%rdg±8dgt[50/60Hz](0 - 40.00A) ±3.5%rdg±6dgt[50/60Hz](15.0 - 299.9A) ±4.0%rdg±6dgt[50/60Hz](300.0 - 400.0A)
DC A	40.00/400.0A (Auto-ranging) ±3.0%rdg±8dgt (0 - 40.00A) ±3.5%rdg±6dgt (15.0 - 299.9A) ±4.0%rdg±6dgt (300.0 - 400.0A)
AC V	400.0/600V(Auto-ranging) ±2.0%rdg±5dgt(50/60Hz)
DC V	400.0/600V(Auto-ranging) ±1.5%rdg±5dgt
Ω	400.0/4000Ω(Auto-ranging) ±2.0%rdg±5dgt
Continuity buzzer	Buzzer sounds below 50±35Ω
Conductor size	φ30mm max.
Applicable Standards	IEC 61010-1 CAT III 300V(ACA) / CAT II 600V Pollution degree 2 IEC 61010-2-032, IEC 61326-1
Power source	R03(1.5V)(AAA) × 2 *Continuous measuring time:Approx.35 hours(Auto power save: Approx.10 min.)
Dimension	187(L) × 68.5(W) × 38.5(D)mm
Weight	Approx. 200g(including batteries)
Accessories	7066A(Test leads), R03(AAA) × 2, Instruction manual
Optional Accessories	9105(Carrying case)

CE

KT 170/171

VOLTAGE TESTERS

CAT IV 600V



CE

CE

photo : KT170

photo : KT171

Probe Protection Cover



KT170/171	
Voltage test	
Voltage range	12 - 690V AC/DC
LED	
Nominal voltage	12/24/50/120/230/400/690V AC(16 - 400Hz), DC(±)
Tolerance (Threshold voltage)	Light on at more than: 7±3V (12V LED) 18±3V (24V LED) 37.5±4V (50V LED) 75%±5% of nominal voltage (120/230/400/690V LED)
Response time	< 0.6s at 100% of each nominal voltage
LCD (KT171 only)	
Range / Resolution (Auto-range)	300V AC/DC (6.0 - 299.9) / 0.1V 690V AC (270 - 759) / 1V 690V DC (270 - 710) / 1V
Accuracy (23±5°C)	±1.5V (7 - 100V) ±1%±5dgt (100 - 690V) AC(16 - 400Hz), DC(±)
Over limit indication	"OL"
Response time	Approx. 1s at 90 - 110% of each voltage
Peak current	Is<3.5mA (at 690V)
Measurement Duty	30s ON (operation time) 240s OFF (recovery time)
Single-pole phase test	
Voltage range	100 - 690V AC (50/60Hz)
Phase rotation test	
System	Three-phase 4-wire system 200 - 690V phase-to-phase AC (50/60Hz)
Phase range	120±5 degree
Continuity test	
Detection range	0 - 400kΩ + 50%
Test current	Approx. 1.5μA (battery 3V, 0Ω)
Operating temperature and humidity range	-15 - 55°C, relative humidity 85% or less (no condensation)
Storage temperature and humidity range	-20 - 70°C, relative humidity 85% or less (no condensation)(KT170) -20 - 60°C, relative humidity 85% or less (no condensation)(KT171)
Applicable Standards	IEC 61243-3, IEC 61010-1, IEC 61557-7 CAT IV 600V / CAT III 690V Pollution degree 2, IEC 60529 (IP65)
Power source	LR03(AAA) (1.5V) × 2
Dimension	246(L) × 64(W) × 26(D)mm
Weight	Approx. 190g (including batteries)
Accessories	LR03(AAA) × 2, KTA01(4mm metal tips[2pcs/set]) KTA02(4mm rubber caps[2pcs/set]), Instruction manual

KT170AU is available for Australia and New Zealand market.

- Comply with the latest standards IEC 61243 and IEC 61010
- Novel design
Large and bright LEDs: Values are visible in the dark place
Ergonomic design fits in the hand
- Two functions are available in one model
"Measurement without battery" and "Self Test (all LED on)"
- Test leads withstand harsh environments at low temperature
- Penlight(white LED)
- Auto power ON/OFF
- Audible indication
- Variable test tips, φ2mm or φ4mm
- Probe protection cover can store the attachment of caps
- IP65 (IEC 60529)

Variable top tips

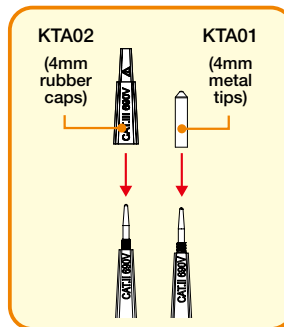

Store the attachment of caps

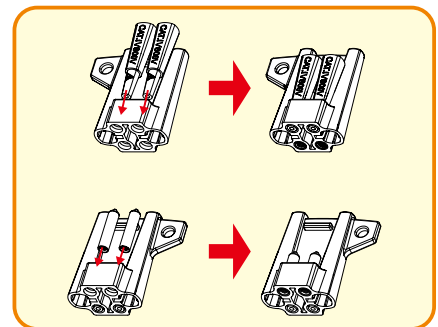

Voltage Test (Double-pole Test)

- The voltage is indicated by LEDs.
- Buzzer sounds and Live circuit LED lights up when a threshold voltage of 50V is exceeded.
- Voltage polarity is indicated in following manner.



AC +DC -DC
+12 - +12 - +12 -

Bright LEDs and Penlight

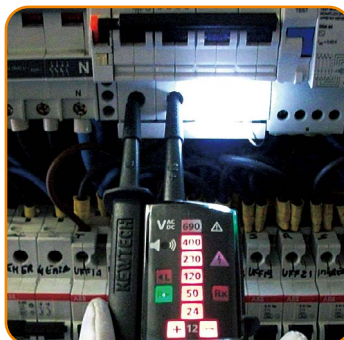

Single-pole Phase Test

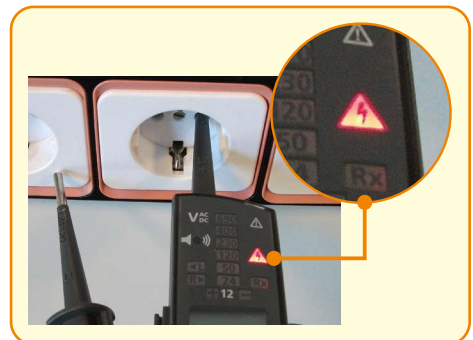

ACCESSORIES

7025

1,500mm

Test leads



Applicable model
3165
3166



7066A

1,100mm

Test leads



Applicable model
1009 2046R
1011 2055
1012 2056R
1020R 2117R
1021R 2127R
1109S KT200
1110 KT203
2007R



7073

2,120mm

2WAY Output cord



Applicable model
2413F
2413R



7082

1,100mm

Leads for recorder



Applicable model
3124A



7083

5,200mm

Leads for battery charging



Applicable model
3124A

7084

5,000mm

Earth and guard leads



Applicable model
3124A



7095A

Earth resistance test leads



Applicable model
4102A
4102A-H
4105A
4105A-H
6018

Green: 5m
Yellow: 10m
Red: 20m

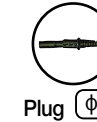

7103A/7139A

Line 1,000mm Earth 1,550mm

Test leads with remote control switch

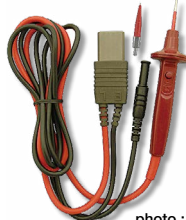

Applicable model
7103A **7139A**
6018 7149A

photo : 7103A

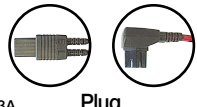

7107A

1,100mm

Test leads



Applicable model
2002PA
2002R
2003A
2009R
2200
2200R



7121B

1,500mm

Distribution board test leads



Applicable model
4118A
5406A



7122B/7217A

Test leads



Plug $\phi 4$

photo : 7122B

1,220mm

Applicable model

7122B **7217A**
3005A 3132A 3132A
3007A 6010B
3131A 6011A



7217A :
For Australia

7123/7124/7125/7126

1,500mm

Molded plug test lead



photo : 7123

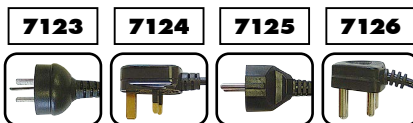

Plug

7123 : (AU) Australian plug
7124 : (UK) British plug (13A)
7125 : (EU) European SCHUKO plug
7126 : (SA) South african plug

Applicable model
4118A
5406A

7127B

1,570mm

Simplified measurement probe



Applicable model
4102A 4105A
4102A-H 4105A-H
4105DL
4105DL-H
4105DLBT-H

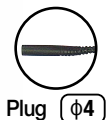

ACCESSORIES

7128A 1,390mm

Test leads



Applicable model
5410



Plug $\phi 4$

7129A 1,450mm

Test lead with alligator clip



Applicable model
5410
6205



Plug $\phi 4$

7132A (KSLP5) 1,200mm

External earth probe



Applicable model
6011A



Plug $\phi 4$

7133B (OMA DIEC) 1,500mm

Distribution board test leads



Applicable model
6010B
6011A

7141B 3,000mm

Voltage test lead set



Applicable model
6305
6315



Plug $\phi 4$

7146 190mm

Banana $\phi 4$ adjuster plug



Applicable model
8121 8127
8122 8128
8123 8146
8124 8147
8125 8148
8126



Plug $\phi 4$

7148 2,000mm

USB cable



Applicable model
5010
5020
6305

7149A/7150A Line 1,000mm Earth 1,550mm

Test leads with remote control switch set



photo : 7149A

Applicable model
7149A 3161A
7150A 6018



7149A Consists of:
7139A (Test leads with remote control switch)
7161A (Flat test prod [black])
7131B (Safety alligator clip [black])
8017 (Extension prod long)
8072 (CAT II Standard prod)
8256 (Extension prod)
9041 (Cord case)
7150A Consists of:
7103A (Test leads with remote control switch)
7161A (Flat test prod [black])
7131B (Safety alligator clip [black])
8017 (Extension prod long)
8072 (CAT II Standard prod)
8256 (Extension prod)
9120 (Cord case)

7153B 1,220mm

Safety test leads



Applicable model
1009 2046R
1011 2055
1012 2056R
1021R 2117R
1110 2127R
2007R



Plug $\phi 4$

7154B 1,220mm

Safety test leads



Applicable model
1009 2117R
1011 2127R
1012 3165
1021R 3166
1110 6010B
2007R 6011A
2046R
2055
2056R



Plug $\phi 4$

7155B

Safety alligator clips with fuse



Applicable model
7153B
7154B

7156B 1,220mm

Safety test leads with fuse



Applicable model
1009 2117R
1011 2127R
1012 3165
1021R 3166
1110 6010B
2007R 6011A
2046R
2055
2056R



Plug $\phi 4$

7157B/7158B

Safety alligator clips / Safety alligator clips for fuse



Applicable model
7153B 7154B
8343

Applicable model
7155B 7156B

photo : 7157B

photo : 7158B

7159B 1,220mm

Safety test leads with fuse



Applicable model
1009 2117R
1011 2127R
1012 3165
1021R 3166
1110 6010B
2007R 6011A
2046R
2055
2056R



Plug $\phi 4$

ACCESSORIES

7165A 3,000mm

Line probe



Applicable model

3025B
3121B
3122B
3123A
3125B
3127

7168A 3,000mm

Line probe with alligator clip



Applicable model

3025B
3121B
3122B
3123A
3125B
3127

7170/7240 2,000mm

Power cord



Applicable model

3128
6305
6315



Plug

photo : 7170

7170 : EU plug 7240 : UK plug

7185 3,000mm

Extension cable



Applicable model

5010 8128
5020 8146
8121 8147
8122 8148
8123
8124
8125
8126
8127

7187A/7218A/7221A/7222A 1,230mm

Mains test lead



photo : 7218A



Plug $\phi 4$

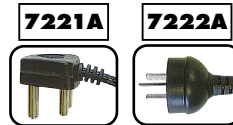
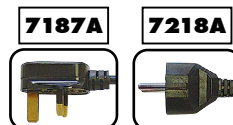

Plug

Applicable model

4140
6516
6516BT

7187A : UK plug
7218A : EU plug
7221A : SA plug
7222A : AU plug

7196B 1,550mm

Test leads with remote control switch



Applicable model

6024PV

7219 1,950mm

USB cable



Applicable model

5050
6315

7220A 1,080mm

Test leads



Applicable model

1051
1052
1061
1062



Plug $\phi 4$

7224A 1,500mm

Earth cord



Applicable model

3123A
3127
3128

7225A 1,500mm

Guard cord



Applicable model

3123A
3127
3128

7226A 3,000mm

Line probe



Applicable model

3128

7227A 3,000mm

Line probe with alligator clip



Applicable model

3128

7228A

Earth resistance test leads



Applicable model

6516 6516BT

Green : 5m
Yellow : 10m
Red : 20m



Plug $\phi 4$

7229A

Earth resistance test leads



Applicable model

4106
Green : 20m
Yellow : 20m
Black : 20m
Red : 40m



Plug $\phi 4$

ACCESSORIES

7234 1,080mm

Alligator clip



Applicable model

1009 1051
1011 1052
1012 1061
1020R 1062
1021R



Plug $\phi 4$

7238A 1,570mm

Simplified measurement test leads



Applicable model

4106



Plug $\phi 4$

7243A 1,650mm

L-shaped probe



Applicable model

3431
3551
3552
3552BT
6024PV

7244A 1,400mm

Alligator clip



Applicable model

6024PV



Plug $\phi 4$

7245A

Precision measurement cord set



Applicable model

4102A
4102A-H
4105A
4105A-H
6018
6024PV

Consists of :
7228A(Earth resistance test leads)
8032(Auxiliary earth spikes[2spikes/set])
8200-03(Cord reels[3pcs])
9142(Carrying case)

Green : 5m
Yellow : 10m
Red : 20m

7246 1,400mm

Distribution board test lead



Applicable model

4140
6516
6516BT



Plug $\phi 4$

7247 1,400mm

Distribution board test lead



Applicable model

4140



Plug $\phi 4$

7248 2,000mm

Test lead with Alligator clip and Flat test probe



Applicable model

4300
6205



Plug $\phi 4$

7253/7254 15m

Longer line probe with alligator clip



Applicable model

7253

3121B 3025B
3122B 3125B
3123A 3127

7254

3128

photo : 7253

7256 1,200mm

Output cord



Applicable model

2002PA 2010
2002R 2500
2003A 2510
2009R



Plug $\phi 4$

7260 1,400mm

Test lead with remote control switch



Applicable model

3431
3551
3552
3552BT

7261A 2,000mm

Test lead with Alligator clip



Applicable model

3431
3551
3552
3552BT



Plug $\phi 4$

7264 3,000mm

Earth cord



Applicable model

3025B
3121B
3122B
3125B

7265 3,000mm

Guard cord



Applicable model

3025B
3121B
3122B
3125B

7266

Earth resistance test leads



Applicable model

4105DL
4105DL-H
4105DLBT-H

Green: 5m
Yellow: 10m
Red: 20m



Plug $\phi 4$

ACCESSORIES

7267/7268

Cable reel for Earth resistance tester



Applicable model
4105DL 6516
4105DL-H 6516BT
4105DLBT-H

7267
Red: 20m

7268
Yellow: 10m

7269 20m

Earth resistance test lead (Red)



Applicable model
4105DL
4105DL-H
4105DLBT-H

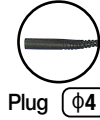

7270 10m

Earth resistance test lead (Yellow)



Applicable model
4105DL
4105DL-H
4105DLBT-H

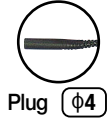

7271 5m

Earth resistance test lead (Green)



Applicable model
4105DL 6516
4105DL-H 6516BT
4105DLBT-H

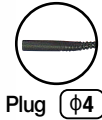

7272

Precision measurement cord set



Applicable model
4105DL 6516
4105DL-H 6516BT
4105DLBT-H

Consists of:
7267(Cable reel for Earth resistance tester (Red))
7268(Cable reel for Earth resistance tester (Yellow))
7271(Earth resistance test lead (Green))
8041(Auxiliary earth spikes(2spikes/1set))
9192(Carrying case for cord reels)

Green: 5m
Yellow: 10m
Red: 20m

7273 3,000mm

Voltage test lead



Applicable model
5050

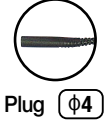

7275 2,000mm

Printer cable



Applicable model
6205

7276 400mm

Adapter for Extension cord



Applicable model
6205

7277 1,440mm

Mains lead



Applicable model
6205

7278 1,500mm

Earth cable



Applicable model
5050

7281 1,400mm

Test leads with remote control switch



Applicable model
6516
6516BT

7284 720mm

Test Lead with IEC connector



Applicable model
4506

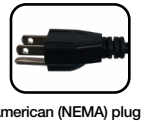

7290 1,500mm

Voltage test lead set



Applicable model
2060BT
2062
2062BT



KAMP10 1,500mm

Test lead with IEC connector

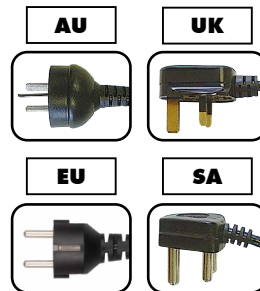

Applicable model
4506
6010B
6011A

AU : Australian plug
UK : British plug (13A)
EU : European SCHUKO plug
SA : South african plug

Plug

*SA plug is not included in the accessories of KEW 4506.

ACCESSORIES

8216 1,000mm

Temperature probe



Applicable model

1011
2046R
2056R

• -50 - 300°C

8405 1,400mm

Temperature probe



Applicable model

1051 1061
1052 1062

• -40 - 500°C, Surface type,
Point material: Ceramic



Plug $\phi 4$

8406 1,380mm

Temperature probe



Applicable model

1051 1061
1052 1062

• -40 - 500°C, Surface type



Plug $\phi 4$

8407 1,540mm

Temperature probe



Applicable model

1051 1061
1052 1062

• -40 - 700°C, Liquid,
Semi-solid



Plug $\phi 4$

8408 1,540mm

Temperature probe



Applicable model

1051 1061
1052 1062

• -40 - 600°C, Air, Gas



Plug $\phi 4$

8901

Fuse [0.5A/250V]



Applicable model

1109S

8918

Ceramic fuse [0.8A/600V]



Applicable model

1011
1012

8919

Ceramic fuse [10A/600V]



Applicable model

1009
1011
1012
1021R
7133B
7155B
7156B
7159B

8923

Fuse [0.5A/600V]



Applicable model

1009 4106
1110 6010B
3005A 6011A
3007A 8031F
3131A 8312
3132A 8329

8926

Fuse [440mA/1000V]



Applicable model

1051
1052
1061
1062

8927

Fuse [10A/1000V]



Applicable model

1051
1052
1061
1062

8928

Fuse [10A/250V]



Applicable model

6205

8930

Fuse [10A/250V]



Applicable model

8602



Scan QR code and get more info about Accessory.

Accuracy

The accuracy of a digital tester is defined as the difference between the reading and the true value for a quantity measured in reference conditions. Accuracy is specified in the format: ($\pm xx\%$ rdg $\pm xx$ dgt)

The first portion identifies a percentage error relative to the reading, which means it is proportional to the input. The second portion is an error, in digits, that is constant regardless of the input.

"Rdg" is for reading and "dgt" is for digits. Dgt indicates the counts on the last significant digit of the digital display and is typically used to represent an error factor of a digital tester.

Auto-discharge Function

A function used immediately after an insulation test to automatically release charges stored within the circuit under test during measurement.

Voltage remaining in the circuit under test can be monitored during auto-discharging process on the display.

Auto-ranging

A function of a tester to automatically select the appropriate measuring range based on the input signal.

Average Value

The average of an AC waveform's instantaneous values taken over a half cycle. Ordinary testers respond to the average value.

For sinusoidal wave :

Average value = Maximum value $\times 2/\pi$ = Maximum value $\times 0.637$

When the True RMS value is 100V ;

Average value = Maximum value $\times 2/\pi$ = $141 \times 0.637 = 90(V)$

The reading of ordinary testers is calibrated in terms of the effective value of a sinusoidal wave even though they are responding to the average value. They are called average-responding-RMS-calibrated type of testers. As opposed to these, True RMS type testers respond and show the True RMS value.

Crest Factor

The ratio of the maximum value to the effective value.

It represents the range of input in which a tester maintains linear operation, expressed by a multiple of the full scale value of the range being used.

Crest factor = Maximum value/True RMS value

For sinusoidal wave;

Crest factor = $141/100 = 1.41$

Data Hold

A function to freeze the reading on a digital display for ease of checking or recording even in a difficult-to-read situation for a tester.

Decibel: dB

A unit used to express the magnitude of change in level of electric signal or sound intensity.

A voltage ratio of 1 to 10 is equal to -20dB, 10 to 1 to 20dB, 100 to 1 to 40dB and 1000 to 1 to 60dB. A power ratio of 10 to 1 is not 20dB, but 10dB, since power(P) is proportional to the square of voltage(V).

Diode Test

A function to apply a diode or a transistor a constant current having a value needed to turn it on in order to check the diode's or the transistor's forward voltage drop and identifying the connection direction of the device.

Distortion Factor

A degree of distortion of a waveform, typically expressed as the ratio of the effective value of harmonic components to the effective value of the fundamental component.

Dual Integration Method

A technique to convert voltage into time. The first integration time (Ts) and the second integration time (Tx) are used. First, the input voltage (Vx) is integrated on a certain time interval (Ts) and then, the resulting voltage is "reverse-integrated" using a reference voltage (Vr) until it becomes 0 (zero).

The "reverse-integration time" (Tx) is proportional to input voltage (Vx). Therefore, the input voltage (Vx) can be determined by measuring Tx.

With this technique, stable measurements can be taken with high accuracy, resolution and noise rejection ratio. One particular advantage is high noise rejection ratio at 50 or 60Hz power line frequency.

Effective Measuring Range of Insulation Tester

The measuring range for which the accuracy of an insulation tester is guaranteed. There are two kinds of effective measuring ranges: the first and second effective measuring ranges.

First effective measuring range

From 1/1000 to 1/2 the maximum effective scale value (When there is no major scale division for 1/2 the maximum effective scale value, the nearest major scale division is used.) (except for 3431)

Second effective measuring range

Scales divisions not included in the first effective measuring range
For example for a 500V/100M Ω insulation tester;
First effective measuring range: 0.1-50M Ω ($\pm 5\%$ of indicated value)
Second effective measuring range: other than above, 0 and ∞ ($\pm 10\%$ of indicated value)

Form Factor

The ratio of the effective value to the average value.

Form factor = Effective value/Average value

Frequency Response

The manner in which a device changes its output quantity, its indication for a measured quantity or its response over a range of frequencies.

AC signals to measure with a tester can be of one frequency or of a wide frequency band ranging from low to high frequencies. To measure these frequencies, it is better to use a tester having a wide frequency response range.

Hall Element

When a current-carrying conductor is placed in a magnetic field so that the direction of the magnetic field is perpendicular to the

GLOSSARY

direction of the current flow, voltage is developed in the direction perpendicular to both the magnetic field and the current flow. This is called the Hall effect and the Hall element is a device that utilizes the effect.

Almost all of the Kyoritsu AC/DC clamp meters and clamp sensors employ the Hall element.

Harmonics

Power line AC voltage from a utility company has near sinusoidal waveform of fundamental frequency with little distortion. When only a load consisting of resistors, capacitance and coils, called a linear load (its constant is fixed regardless of the amount of current flowing through it), is connected to mains supply, no distortion is introduced into the load current waveform. However, when a non-linear load, such as a semiconductor and a saturable reactor, is connected, distortion appears in the load current waveform. The current with a waveform containing distortion, or harmonic current, flows in the direction toward the low impedance side and in the process, produces voltage drop over the impedance of the current path, causing the load voltage also to contain harmonics.

Indicated Value

The value indicated by a tester for a measured quantity

Peak Hold

A function to memorize the peak value over a certain period of time.

*Response time is normally approx. 10ms.

Reading in the peak hold mode are two types. (the peak of current crest value and the peak current value multiplies by $1/\sqrt{2}$)

Peak Value

The value at a point where a waveform has the maximum amplitude.

Resolution

The minimum increments in which a tester can take measurements.

Sample Rate

Frequency at which an A/D converter circuit senses the quantity to measure: typically, twice or three times per second.

Sensitivity

The ability of a tester to respond to the quantity to measure, expressed as the ratio of a change induced in the reading to a change in the input:

$$\text{Sensitivity} = \frac{\text{Change in reading}}{\text{Change in quantity to measure}}$$

Shock Hazard

Also referred to as electric shock. When a person touches a motor that has a "leak", a path can be created from the motor frame to the hand, body and feet of the person to the floor he is standing on to allow a current to flow through it, sometimes resulting in a fatal accident.

The seriousness of a shock hazard widely varies depending on the amount and duration of the current that flows through the person's body. His constitution, age and medical condition are also variation factors, but in general, at a frequency of 50 or 60Hz, stimulus to the skin is felt at 1mA, considerable pain occurs at 5mA, pain is unbearable at 10mA, there is difficulty in releasing the "leaking" object because of intense muscle contraction at 20mA, it is considerably dangerous at 50mA and fatality is likely at 100mA. For the safety limit for a fatal current, which causes ventricular fibrillation, Professor Dalziel proposed the following equation from numbers of experiments on animals.

$$I = 165 \sqrt{t}$$

Where, I = current (mA) and t = time (sec).

From this theory, the maximum duration for a current of 165mA is 1 second.

Thermocouple

A device that uses the voltage developed by the junction of two dissimilar metals to measure temperature. One junction, called the measuring junction, is placed at the point where temperature is to be measured. The other junction, called the reference junction, is maintained at a reference temperature. The voltage developed between the two junctions varies depending on the difference between the temperatures of the two junctions and the type of thermocouple.

True RMS Value

The square root of the average of the square of a periodic waveform's instantaneous values taken over one cycle. It is also called the rms value and the most closely relates to such form of energy as force and heat.

(The effective value of an alternating current is expressed as the value of the direct current which produces the same amount of heat as the alternation current does.)

For sinusoidal wave :

$$\text{True RMS} = \text{Maximum value} \times 1/\sqrt{2} = \text{Maximum value} \times 0.707$$

When a True RMS is 100V ;

$$\text{Maximum value} = \text{True RMS} \times \sqrt{2} = 100 \times 1.41 = 141(\text{V})$$

Measurement categories

To ensure safe operation of measuring instruments, IEC 61010 establishes safety standards for various electrical environments, categorized as O to CAT IV, and called measurement categories. Higher-numbered categories correspond to electrical environments with greater momentary energy, so a measuring instrument designed for CAT III environments can endure greater momentary energy than one designed for CAT II.

O : Measuring circuits without a MEASUREMENT CATEGORY.

CAT II : Electrical circuits of equipment connected to an AC electrical outlet by a power cord.

CAT III : Primary electrical circuits of the equipment connected directly to the distribution panel, and feeders from the distribution panel to outlets.

CAT IV : The circuit from the service drop to the service entrance, and to the power meter and primary overcurrent protection device (distribution panel).

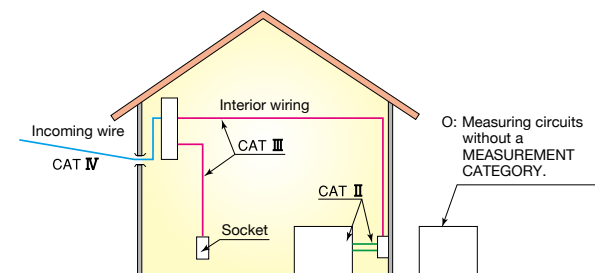

PRODUCT INDEX

1000

1009	Digital Multimeter	16
1011	Digital Multimeter	16
1012	Digital Multimeter	16
1019R	Digital Multimeter	17
1020R	Digital Multimeter	15
1021R	Digital Multimeter	15
1030	Digital Multimeter (Pen type)	17
1051	Digital Multimeter	18
1052	Digital Multimeter	18
1061	Digital Multimeter	18
1062	Digital Multimeter	18
1109S	Analog Multimeter	16
1110	Analog Multimeter	16

2000

2000A	Digital Multimeter	20
2001A	Digital Multimeter	20
2002PA	Digital Clamp Meter	24
2002R	Digital Clamp Meter	24
2003A	Digital Clamp Meter	27
2007R	Digital Clamp Meter	24
2009R	Digital Clamp Meter	27
2010	Digital Clamp Meter	27
2012RA	Digital Multimeter	20
2031	Digital Clamp Meter	24
2033	Digital Clamp Meter	28
2046R	Digital Clamp Meter	28
2055	Digital Clamp Meter	28
2056R	Digital Clamp Meter	28
2060BT	Clamp Power Meter	69
2062	Clamp Power Meter	69
2062BT	Clamp Power Meter	69
2117R	Digital Clamp Meter	25
2127R	Digital Clamp Meter	25
2200	Digital Clamp Meter	25
2200R	Digital Clamp Meter	25
2204R	Digital Clamp Meter	26
2210R	Digital Clamp Meter	26
2300R	Fork Current Tester	31
2413F	Leakage Clamp Meter	31
2413R	Leakage Clamp Meter	31
2431	Leakage Clamp Meter	30
2432	Leakage Clamp Meter	30
2433	Leakage Clamp Meter	30
2433R	Leakage Clamp Meter	30
2434	Leakage Clamp Meter	31
2500	DC Milliamp Clamp Meter	29
2510	DC Milliamp Clamp Logger	29

3000

3005A	Digital Insulation/Continuity Tester	36
3007A	Digital Insulation/Continuity Tester	36
3025B	High Voltage Insulation Tester	43
3121B	High Voltage Insulation Tester	41
3122B	High Voltage Insulation Tester	41
3123A	High Voltage Insulation Tester	42
3124A	High Voltage Insulation Tester	42
3125B	High Voltage Insulation Tester	43
3127	High Voltage Insulation Tester	44
3128	High Voltage Insulation Tester	45
3131A	Analog Insulation/Continuity Tester	38
3132A	Analog Insulation/Continuity Tester	38
3161A	Analog Insulation Tester	39
3165	Analog Insulation Tester	39

3166	Analog Insulation Tester	39
3431	Analog Insulation Tester	39
3551	Digital Insulation/Continuity Tester	37
3552	Digital Insulation/Continuity Tester	37
3552BT	Digital Insulation/Continuity Tester	37

4000

4102A	Earth Tester (Soft case model)	50
4102A-H	Earth Tester (Hard case model)	50
4105A	Earth Tester (Soft case model)	50
4105A-H	Earth Tester (Hard case model)	50
4105DL	Earth Tester (Cable reel set model)	48
4105DL-H	Earth Tester (Hard case model)	48
4105DLBT-H	Earth Tester (Hard case model)	49
4106	Earth Tester	51
4118A	LOOP/PSC Tester	54
4140	LOOP/PFC/PSC Tester	55
4200	Earth Clamp Tester	52
4202	Earth Clamp Tester	52
4300	Simplified Earth Tester	51
4506	Intelligent Socket Tester	82

5000

5010	AC Current Logger	74
5020	AC Current/Voltage Logger	74
5050	Ior Logger	76
5050-01	5050 + 8178 × 1 + 9125	77
5050-02	5050 + 8177 × 1 + 9125	77
5202	Digital Light Meter	84
5204	Digital Light Meter	84
5204BT	Digital Light Meter	84
5406A	RCD Tester	56
5410	RCD Tester	56
5515	Infrared Thermometer	85
5711	Voltage Detector	84

6000

6010B	Multi Function Tester	60
6011A	Multi Function Tester	61
6018	Multi Function Tester	61
6024PV	PV Insulation Earth Tester	62
6205	Portable Appliance Tester	58
6305	Power Meter	70
6305-01	6305 + 8125 × 3 + 9125	71
6305-03	6305 + 8130 × 3 + 9135	71
6305-05	6305 + 8133 × 3 + 9135	71
6315	Power Quality Analyzer	72
6315-01	6315 + 8125 × 3 + 9125	73
6315-03	6315 + 8130 × 3 + 9135	73
6315-04	6315 + 8130 × 4 + 9135	73
6315-05	6315 + 8133 × 3 + 9135	73
6516	Multi Function Tester	64
6516-EV2	6516+8602	67
6516BT	Multi Function Tester	64
6516BT-EV2	6516BT+8602	67

7000

7025	Test leads	39,88
7066A	Test leads	15,16,24,25,28,86,88
7073	2WAY Output cord	31,88
7082	Leads for recorder	42,88
7083	Leads for battery charging	42,88
7084	Earth and guard leads	42,88
7095A	Earth resistance test leads	50,61,88
7103A	Test leads with remote control switch	61,88

PRODUCT INDEX

7107A	Test leads	24,25,27,88	7270	Earth resistance test lead (Yellow)	48,49,92
7121B	Distribution board test leads	54,56,88	7271	Earth resistance test lead (Green)	48,49,65,92
7122B	Test leads	36,38,60,61,88	7272	Precision measurement cord set	48,49,65,92
7123	Molded plug test lead [AU]	54,56,88	7273	Voltage test lead	76,77,92
7124	Molded plug test lead [UK]	54,56,88	7275	Printer cable	58,92
7125	Molded plug test lead [EU]	54,56,88	7276	Adapter for Extension cord	58,92
7126	Molded plug test lead [SA]	54,56,88	7277	Mains lead	58,92
7127B	Simplified measurement probe	48-50,88	7278	Earth cable	76,77,92
7128A	Test leads	56,89	7281	Test leads with remote control switch	64,65,92
7129A	Test lead with alligator clip	56,58,89	7284	Test lead with IEC connector	82,92
7131B	Safety alligator clip [black]	61	7290	Voltage test lead set	69,92
7132A(KSLP5)	External earth probe	61,89			
7133B(OMA DIEC)	Distribution board test leads	60,61,89	8000		
7139A	Test leads with remote control switch	88	8016	Hook type prod	37,39,61,62,63
7141B	Voltage test lead set	70,72,89	8017	Extension prod long	51,56,61,62,63
7146	Banana ϕ 4 adjuster plug	19,79,80,89	8017A	Extension prod long	37,39,65
7148	USB cable	70,74,89	8019	Hook type prod	41-44
7149A	Test leads with remote control switch set	39,89	8029	Extension prod	45
7150A	Test leads with remote control switch set	61,89	8031	Phase indicator	85
7153B	Safety test leads	89	8031F	Phase indicator	85
7154B	Safety test leads	89	8032	Auxiliary earth spikes [2spikes/1set]	50,51
7155B	Safety alligator clips with fuse	89	8035	Non-contact Phase Indicator	85
7156B	Safety test leads with fuse	89	8041	Auxiliary earth spikes [2spikes/1set]	48,49,64,65
7157B	Safety alligator clips	82,89	8072	CAT II Standard prod	51,62,63
7158B	Safety alligator clips for fuse	89	8112	AC Clamp Adapter	33
7159B	Safety test leads with fuse	89	8115	Clamp Sensor	15,19,33
7161A	Flat test prod [black]	58,61	8121	Load current Clamp Sensor	19,74,76,78,80
7165A	Line probe	41-44,90	8122	Load current Clamp Sensor	19,74,76,78,80
7168A	Line probe with alligator clip	41-44,90	8123	Load current Clamp Sensor	19,74,76,78,80
7170	Power cord [EU]	45,70,72,90	8124	Load current Clamp Sensor	70-74,76,78,79
7185	Extension cable	74,78-80,90	8125	Load current Clamp Sensor	70-74,76,78,79
7187A	Mains test lead [UK]	55,64,65,90	8126	Load current Clamp Sensor	70-74,76,78,79
7196B	Test leads with remote control switch	62,63,90	8127	Load current Clamp Sensor	70-74,76,78,79
7217A	Test leads	38,88	8128	Load current Clamp Sensor	70-74,76,78,79
7218A	Mains test lead [EU]	55,64,65,90	8130	Flexible Clamp Sensor	70-74,76,78,79
7219	USB cable	72,76,77,90	8133	Flexible Clamp Sensor	70-73,76,78,79
7220A	Test leads	18,90	8135	Flexible Clamp Sensor	70-74,78,79
7221A	Mains test lead [SA]	55,64,65,90	8146	Leakage & Load current Clamp Sensor	19,72-74,76,78,80
7222A	Mains test lead [AU]	55,64,65,90	8147	Leakage & Load current Clamp Sensor	19,72-74,76,78,80
7224A	Earth cord	42,44,45,90	8148	Leakage & Load current Clamp Sensor	19,72-74,76,78,80
7225A	Guard cord	42,44,45,90	8161	Clamp Sensor	15,33
7226A	Line probe	45,90	8177	Ior Leakage current Clamp Sensor	76-78
7227A	Line probe with alligator clip	45,90	8178	Ior Leakage current Clamp Sensor	76-78
7228A	Earth resistance test leads	50,64,65,90	8200-03	Cord reel [3pcs]	50
7229A	Earth resistance test leads	51,90	8200-04	Cord reel [4pcs]	51
7234	Alligator clip	15,16,19,91	8212-USB	USB adapter with "KEW Report(Software)"	37,51,60,62,63,64,65
7238A	Simplified measurement test leads	51,91	8212-USB-W	USB adapter with "KEW Windows(Software)"	45
7240	Power cord[UK]	45,70,72,90	8216	Temperature probe	16,28,93
7243A	L-shaped probe	37,39,62,63,91	8241	USB Communication set	19
7244A	Alligator clip	62,63,91	8253	CAT III Standard prod	51
7245A	Precision measurement cord set	50,61-63,91	8258	USB communication set	44
7246	Distribution board test lead	55,64,65,91	8259	Adapter for measurement terminal	48-50,65
7247	Distribution board test lead	55,91	8262	AC adapter	76,77
7248	Test lead with Alligator clip and Flat test probe	51,58,91	8263-USB	USB cable with "KEW Report(Software)"	58
7253	Longer line probe with alligator clip	41-44,91	8264A	Battery charger[AU]	42
7254	Longer line probe with alligator clip	45,91	8266	Battery charger	42
7256	Output cord	24,27,29,91	8267	Battery charger	42
7260	Test lead with remote control switch	37,39,91	8268	Ni-MH rechargeable battery	42
7261A	Test lead with Alligator clip	37,39,91	8302	Adapter for recorder	43,44
7264	Earth cord	41,43,91	8304	Resister for operation check	52
7265	Guard cord	41,43,91	8309	Voltage sensor	74,78
7266	Earth resistance test leads	48,49,91	8312	Power supply adapter	70,71,73,78
7267	Cable reel for Earth resistance tester (Red)	48,49,65,92	8320	AC adapter	29,74,78
7268	Cable reel for Earth resistance tester (Yellow)	48,49,65,92	8324	Adapter for recorder	41,42
7269	Earth resistance test lead (Red)	48,49,92	8326-02	SD card [2GB]	70,72,73,76,77

PRODUCT INDEX

8327EU	Power adapter 15V/1A	44
8329	Power supply adapter	76-78
8343	Signal source for Intelligent Socket Tester	82
8405	Temperature probe	19,93
8406	Temperature probe	19,93
8407	Temperature probe	19,93
8408	Temperature probe	19,93
8601	EVSE Adapter	66
8602	EVSE Adapter	66
8603	TYPE1 to TYPE2 Conversion Adapter	66
8901	Fuse [0.5A/250V]	16,93
8918	Ceramic fuse [0.8A/600V]	16,93
8919	Ceramic fuse [10A/600V]	15,16,93
8923	Fuse [0.5A/600V]	16,36,38,51,60,61,85,93
8926	Fuse [440mA/1000V]	18,93
8927	Fuse [10A/1000V]	18,93
8928	Fuse [10A/250V]	58,93
8930	Fuse [10A/250V]	66,93

9000

9029	Carrying case	85
9074	Cord case	36,38,39
9079	Carrying case	24,25
9084	Soft case	50,64,65
9090	Carrying case	24,28,30
9092	Cord case	60,61
9094	Carrying case	24,27,28,31,78-80,85
9095	Carrying case	16,27,33,78-80
9096	Carrying case	29,82,85
9097	Carrying case	15,30,31
9103	Carrying case	16
9105	Carrying case	86
9107	Soft case	20
9113	Carrying case	31
9118	Carrying case	74
9121	Shoulder strap	36-39,48-51,54,56,58,60,61
9123	Shoulder strap	39
9125	Carrying case	51,70-73,76,77
9130	Carrying case	17
9132	Carrying case with magnet	70,71,73,78
9135	Carrying case	71,73,74,78
9142	Carrying case	50,64,65
9147	Cord case	54,56
9151	Shoulder strap	64,65
9152	Carrying case	85
9154	Carrying case	19
9155	Shoulder strap	55,62
9156A	Soft case	55,62,63
9158	Carrying case [Hard]	42
9160	Carrying case	25
9161	Carrying case	51,82
9164	Carrying case [Hard]	50
9165	Carrying case [Hard]	50
9166	Carrying case [Hard]	52
9167	Carrying case [Hard]	52
9168	Carrying case	16
9171	Carrying case [Hard]	44
9173	Carrying case	37,39
9174	Carrying case	26
9176	Carrying case [Hard]	42
9182	Carrying case [Hard]	41
9183	Carrying case [Hard]	41
9186A	Carrying case	37,39
9187	Cord case	37,39
9188	Hard case	17

9189	Magnet hanger strap	15
9190	Carrying case	48,49
9191	Carrying case[Hard]	48,49
9192	Carrying case for cord reels	48,49,65
9193	Carrying case	58
9195	Carrying case	84
9197	Carrying case[Hard]	49
9198	Carrying case	69
9199	Shoulder pad	64,65
9202	Carrying case	66
9203	Carrying case[Hard]	43
9204	Carrying case[Hard]	43
KAMP10	Test lead with IEC connector	60,61,82,92
KT170	Voltage Tester	87
KT171	Voltage Tester	87
KT200	Digital Clamp Meter	86
KT203	Digital Clamp Meter	86
KTA01	4mm metal tips [2pcs/set]	87
KTA02	4mm rubber caps [2pcs/set]	87

QUALITY CONTROL CONCEPT

Kyoritsu started early an effort to establish system that ensures traceability to the national standards in order to produce reliable instruments as well as instruments that can assure reliability of other equipment and installations.

When traceability is in place, measurements taken with an instrument any time and anywhere in any situation can be related to the appropriate national measurement standards through a clear and unbroken chain of comparisons.

For example, in terms of measurement defined by JIS (Japanese Industrial Standards), traceability is specified as a condition in which a calibration path is established from instruments produced or in-house standards to higher level standards to the national standards. Kyoritsu currently has a system in place as shown in the figure below.

Our calibrator (standard) is calibrated at Japan Electric Meters Inspection Corporation (JEMIC), Japan Quality Assurance Organization (JQA) and Fluke Japan who perform calibration based on the units established and maintained by National Institute of Advanced Industrial Science and Technology (AIST). The standard is used as the in-house standard to calibrate all the test and measuring equipments which are used in-house.

Voltage : Precision calibrators are used as in-house DC and AC voltage standards.

Current : DC or AC current is converted to a voltage by a standard resistor, and the voltage is calibrated with a precision digital multimeter.

Resistance : Calibration resistors are calibrated with a DC standard current generator and the precision digital multimeter.

Calibration System for Electrical Measuring Instruments

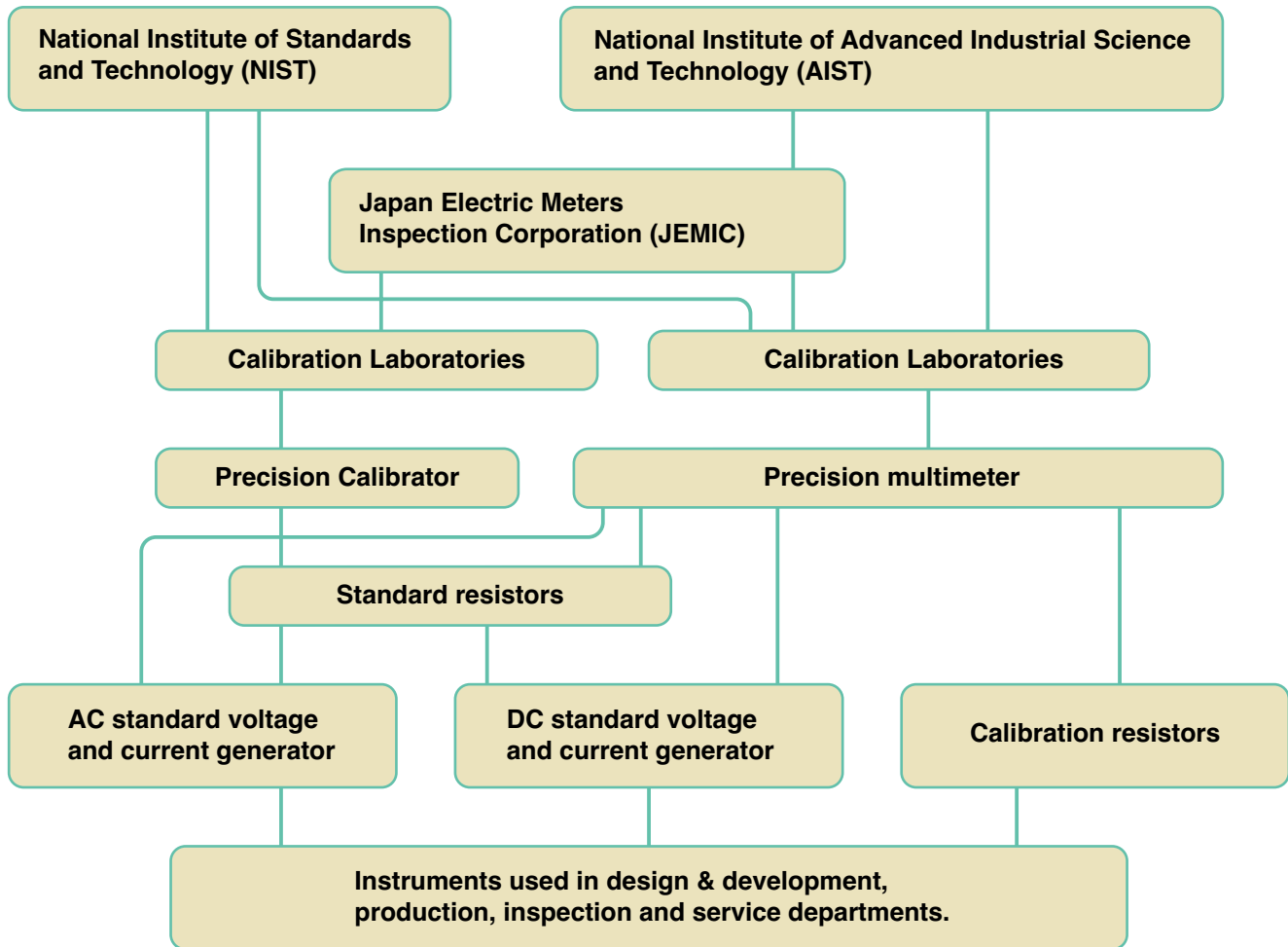

CE Marking: signifies conformance to
 EMC directive (2014/30/EU)
 LVD directive (2014/35/EU)
 RoHS directive (2011/65/EU + (EU)2015/863)



- Headquarter
- Factory
- Affiliates

KYORITSU GLOBAL NETWORK

● KYORITSU ELECTRICAL INSTRUMENTS WORKS, LTD.

2-5-20, Nakane Meguro-ku, Tokyo,
152-0031 Japan
Phone: +81-3-3723-0131
FAX: +81-3-3723-0152

● EHIME FACTORY

480 Sakado, Uwa-cho, Seiyō City, Ehime,
797-0045 Japan

● KEW (THAILAND) LIMITED

Navanakorn Industrial Estate 60/48, Moo 19,
Klongluang, Pathumthani, 12120 Thailand
Phone: +66-2-529-0542
FAX: +66-2-529-0541

● KYORITSU INSTRUMENTS ASIA PTE. LTD.

4008 Ang Mo Kio Ave 10, #02-20/21,
Techolace-1, Singapore 569625
Phone: +65-6336-3398
FAX: +65-6336-1696

● KEW EUROPE OFFICE

Viale Brianza 181, 20092 Cinisello Balsamo,
Milano, Italy
Phone: +39-34-74149005

● KEWTECH CORPORATION LIMITED

Suite 3 Halfpenny Court, Halfpenny Lane,
Sunningdale, Berkshire, SL5 0EF, England
Phone: +44-3456-461404

● KYORITSU SHANGHAI TRADING COMPANY LIMITED

Room 1303, No. 58 Yan'an East Road,
Huangpu District, Shanghai 200002, China
Phone: +86-21-6321-8899
FAX: +86-21-5015-2015
URL: <http://www.kew-ltd.com.cn>
E-mail: info@kew-ltd.com.cn



Official Website
www.kew-ltd.co.jp



Facebook



Instagram



 **YouTube**



Safety Warnings :

Please read the "Safety Warnings" in the instruction manual supplied with the instrument thoroughly and completely for correct use. Failure to follow the safety rules can cause fire, trouble, electrical shock, etc. Therefore, make sure to operate the instrument on a correct power supply and voltage rating marked on each instrument.

■ For inquiries or orders :